

FAULT FINDING MANUAL

For Self Excited and Separately Excited Generators

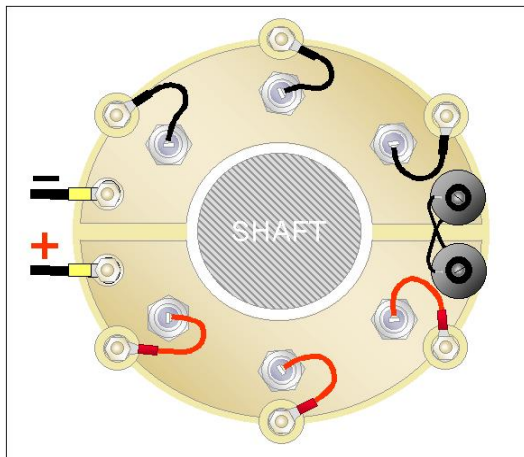
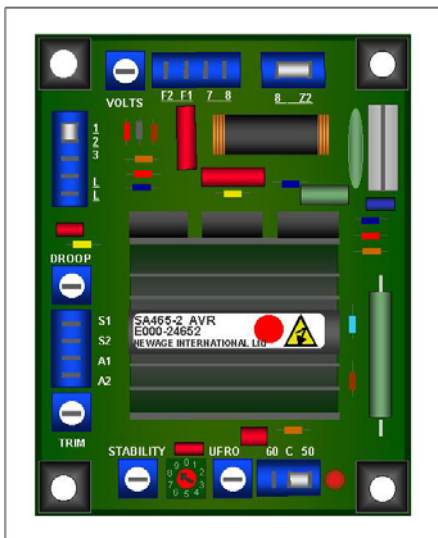
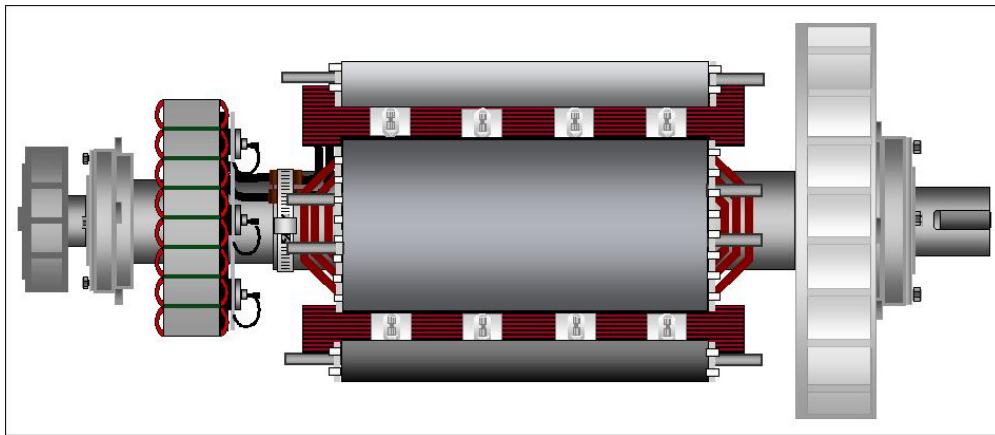

SAFETY PRECAUTIONS

Before testing the generating set, read the generating set Installation Manual, and this Fault Finding Manual, and become familiar with it and the equipment.

SAFE AND EFFICIENT OPERATION CAN ONLY BE ACHIEVED IF THE EQUIPMENT IS CORRECTLY INSTALLED, OPERATED AND MAINTAINED.

Many accidents occur because of a failure to follow fundamental rules and precautions.

ELECTRICAL SHOCK CAN CAUSE SEVERE PERSONAL INJURY OR DEATH.

- Ensure installation meets all applicable safety and local electrical codes. Have all installations performed by qualified Installation technicians.
- Do not operate the generator with protective covers, access covers or terminal box covers removed.
- Disable engine starting circuits before carrying out maintenance.
- Disable closing circuits and/or place warning notices on any circuit breakers normally used for connection to the mains or other generators, to avoid accidental closure.

Observe all IMPORTANT, CAUTION, WARNING, and DANGER notices, defined as:

Important ! Important refers to hazard or unsafe method or practice, which can result in product damage or related equipment damage.

Caution ! Caution refers to hazard or unsafe method or practice, which can result in product damage or personal injury.



Warning !

Warning refers to a hazard or unsafe method or practice, which CAN result in severe personal injury or possible death.



Danger !

Danger refers to immediate hazards, which WILL result in severe personal injury or death.

TESTING "LIVE" EQUIPMENT

It is essential that all test instruments are regularly checked for safety, and any connection leads, probes, or clips, are checked to ensure that they are suitable for the voltage levels being tested.



Danger !

Never attempt to test a "LIVE" generator unless there is another competent person present who can switch off the power supply or shut down the engine in an emergency.

Never expose "LIVE" connections unless you have created a safe working area around you. Make sure you have made all other persons in the immediate area fully aware of what you are doing.

FAULT FINDING MANUAL

SECTION 1

Recommended Metering and Test Instruments

SECTION 2

Electrical Terminology

SECTION 3

Fault Finding method 'A', for All Generators

SECTION 4

Fault Finding method 'B', for Self-Excited Generators.

Automatic Voltage Regulator is powered from the Generator Output.

SECTION 5

Fault Finding method 'B', for Separately Excited Generators

Automatic Voltage Regulator is powered from the Permanent Magnet Generator.

SECTION 6

Parallel Operation and Fault Finding for All Generators

SECTION 1

RECOMMENDED METERING AND TEST INSTRUMENTS

To successfully carry out the various test procedures suggested in this manual, certain test instruments are essential. The following lists detail the basic requirements in this respect.

It should be noted that in addition to these instruments a comprehensive kit of tools is also essential. For fault finding purposes this need not include any specialised tools.

Item 1 - Multimeter

The Multimeter is a comprehensive test instrument for measuring voltage, current and resistance. It should be capable of measuring the following ranges:-

Voltage A C	0-250-500-1000 Volts
Voltage D C	0-25-100-250 Volts
Amperes D C	0-10 Amps
D C Resistance	0-10k (ohms) or 0-2k (ohms) 0-100k (ohms) or 0-20k (ohms) 0-1M (ohms) or 0-200k (ohms)

Item 2 – Tachometer or Frequency meter

This instrument is for measuring the shaft speed of the alternator and should be capable of measuring speeds between 0 and 5000 revolutions per minute, (RPM).

An alternative to the tachometer is the frequency meter (see Section 2 on Frequency and Speed, for details). However the alternator must be generating its normal output voltage for this instrument to be accurate.

Item 3 – Megger (Insulation test meter)

This instrument generates a voltage of 500V or 1000V, and is used to measure the resistance value of the insulation to earth (ground). It may be an electronic push button type, or a hand cranked generator type.

Item 4 - Clip-On Ammeter (Clampmeter)

Used to measure A C current, it consists of a pair of callipers, which are clamped around the conductor, and by means of a transformer action, gives an indication of the amperes flowing in the conductor. Useful ranges to have on this meter are:-

A C Amps 0-10-50-100-250-500-1000

Item 5 – Kelvin Bridge – low resistance meter

This instrument is used to measure resistance values below 1.0 ohm. They are bulky, and expensive, but are the only means of accurately measuring very low resistances, such as main stator and exciter rotor windings.

However, there are other methods of testing low resistance windings, and these are included in the various test procedures, i.e. Test Method A (Section 3). This section will enable the main generator windings to be tested while running the generator at normal speed without load.



Danger !

It is essential that all test instruments be regularly checked for safety, and any connection leads, probes or clips checked to ensure that they are suitable for the voltage levels being tested.

Never attempt to test a "LIVE" generator unless there is another competent person present who can switch off the power supply or shut down the engine in an emergency.

Never expose "LIVE" connections unless you have created a safe working area around you. Make sure you have made all other persons in the immediate area fully aware of what you are doing.



Danger !

**MEDIUM/HIGH VOLTAGE
3.3 kVA to 11.0 kVA**

Do not attempt to carry out tests on medium or high voltage generators without using specialised instruments and probes, with suitable protection equipment and procedures for grounding (earthing) the output terminals.

SECTION 2

ELECTRICAL TERMINOLOGY AND RESISTANCES VOLTAGE AND CURRENT (AMPERES)

An AC Generator is designed to produce a voltage level suitable for the load to which it is connected. The control circuits are designed to automatically maintain this voltage level as the load is increased or decreased.

Sudden large changes in loading will produce temporary changes in the voltage. The control circuit is designed to recover to a stable condition as quickly as possible.

The current drawn from the AC Generator is determined by the amount of load connected to it. Current creates a temperature rise in the windings, hence the requirement for drawing air through the AC Generator by means of the fan. If the full load rated current is exceeded on any phase of the main stator windings, it will result in overheating in this winding. Similarly, any restriction in the flow of air through the machine will result in a rapid increase in the temperature of the windings.

Frequency (Hz) and Speed (RPM)

An AC Generator is a constant speed device, and should not be operated at speeds above 4% of the rated speed, or more than 1% below the rated speed.

Load changes will create temporary changes in the speed, but the engine must be capable of returning to the steady state condition within a few seconds.

The speed requirements for the AC Generator are determined by:-

- (a) The frequency (Hz) requirement of the load
- (b) The number of poles, (main rotor coils), in the generator

$$\text{Frequency (HZ)} = \frac{N (\text{speed}) \times P (\text{pairs of poles})}{60 (\text{sec's})}$$

This can be shown more clearly in a chart: -

Frequency (Hz)	Speed (R.P.M.)	No. of Poles (rotor coils)
50	1500	4
60	1800	4
50	1000	6
60	1200	6
50	3000	2
60	3600	2

From this chart, a simple formula is produced to calculate the speed from the frequency, or vice versa.

- 4 pole machine 1 cycle (Hz) = 30 R.P.M.
- 6 pole machine 1 cycle (Hz) = 20 R.P.M.
- 2 pole machine 1 cycle (Hz) = 60 R.P.M.

Kilowatts (kW) kilo Volt Amperes (kVA) and Power Factors (pf.)

For an AC Generator to supply power for a load of 1kW, the prime mover (engine) driving the alternator must produce approximately 1.5 horsepower.

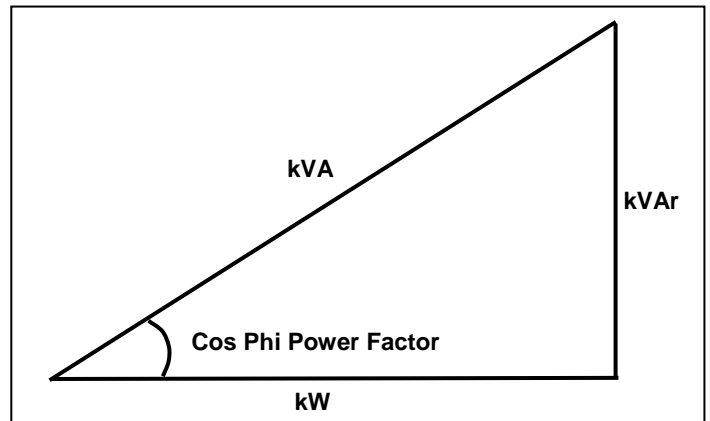

Kilowatts are calculated by the formula: -

$$\text{kW} = \frac{\text{Volts} \times \text{Amperes} \times \text{Power Factor}}{1000}$$

kVA (kilo Volt Amperes), are calculated by the formula:-

$$\text{kVA} = \frac{\text{Volts} \times \text{Amperes}}{1000}$$

Both equations are multiplied by $\sqrt{3}$ (1.732) for a 3 phase machine.

Power Factor

The Power Factor (pf), is a measure of wasted current, which is a product of inductive loads such as motors, transformers, (magnetic circuits), and some forms of lighting.

The formula for calculating the Power Factor is:-

$$\text{pf} = \frac{\text{kilowatts}}{\text{kVA}}$$

Unity Power Factor (pf 1)

Purely resistive load, i.e. heating, tungsten filament lighting, has a power factor of one, (pf 1), and contains very little Wattless (inductive) load, which is power factor zero, (pf 0).

An AC Generator will deliver continuously the rated full load current at any power factor between pf 1 (unity) and 0.8. However, the prime mover, (engine), is greatly affected by the power factor. At pf 1, the kVA and kW are equal; therefore the engine is supplying 20% more kW load at pf 1, than it is at pf 0.8. It is important, therefore, that this is taken into consideration, when approaching 75% to 100% load current of the Generator, with a power factor higher than 0.8.

Lagging Power Factors

A Generator is designed to deliver the full load current at any power factor between unity and 0.8 lagging. Certain loads have a power factor lower than 0.8 lag, e.g. welding transformers; autotransformer, start motors, gas discharge lighting. A reduction in the full load (kVA), rating is required for a lagging pf lower than 0.8.

Leading Power Factors

Capacitive load e.g. some fluorescent lighting, power factor correction capacitor banks, produce leading power factor current. The latter is required by the Electricity authorities to improve the customers lagging power factor. The capacitor bank size is measured in kVAr (reactive).

A purely Capacitive load can cause the Generator control system, (AVR), to loose control, creating voltage instability, and possible high voltage from the Generator.

This is due to the fact that, unlike most loads, which are pf 1, (unity) or lagging pf, a leading pf load current will cause the Generator excitation voltage to decrease, as the load current increases.

Eventually the control system will be unable to control the Generator excitation level, and voltage instability will occur.

The degree of instability is determined by the kVAr size of the capacitors, relative to the kVA size of the alternator.

Capacitive load can present a problem for mains failure (standby) Generators. When the mains electricity supply fails, all motor, (inductive), load is disconnected by the individual contactors. Subsequently, when the Generator is connected to the system, the load will mainly consist of lighting, and possibly the power factor correction capacitors. In this situation the AC Generator will see a very low, (leading), power factor, and may become unstable, and/or generate high voltage.

In order to prevent this situation, it is advisable to ensure that the power factor correction capacitors are switched OFF when the generator takes the initial load.

Resistances - measuring component values

When fault finding it is necessary to measure the resistance values of components and windings, and compare them with known normal values, in order to identify a faulty winding. The normal resistances of the windings are given in the winding resistance charts, in the generator installation and maintenance handbooks, service and maintenance section.

Resistance values above 10 ohms can be measured accurately with a multimeter. Between 0.5 and 5 ohms a multimeter has a limited accuracy, and other test methods may be adopted.

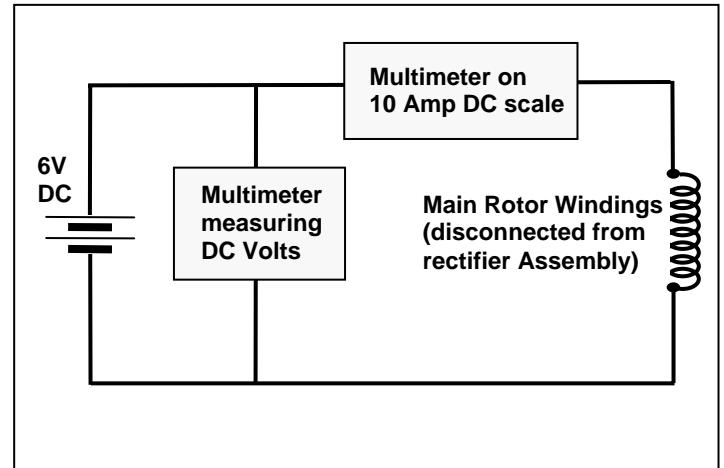

Resistances between 0.5 And 5 Ohms

The resistance value of a winding such as a brushless main rotor will be between 0.5 and 3 ohms. A multimeter may not give an accurate enough reading at these levels. If a Wheatstone Bridge Resistance Meter is not available, an accurate measurement can be obtained by means of a battery supply, using a Multimeter in series on the 10 Amps D.C. range. Most Multimeters have this current range, or alternatively, a battery charging Ammeter could be used instead).

Using 6 volt battery cells the resistance of the winding can be calculated i.e.

$$\frac{V \text{ (volts)}}{I \text{ (amps)}} = \text{ohms (resistance)}$$

The resultant can be compared with the correct value given in the resistance charts, and this method can be used for any resistance greater than 0.5 ohm.

Below this value the current in the circuit would drain the battery, and it is therefore impractical to use this method.

Very low resistance values (below 0.5 ohm)

Main stators and exciter rotors are included in this category.

These values can only be measured accurately with a special instrument, such as a Kelvin bridge test meter.

The test leads are equipped with special spiked probes, which penetrate the surface of the contact, ensuring accurate reading.

The generators main stator windings can also be tested by means of separately exciting the machine (see, Section 3, Test Method A), thus partly eliminating the need to have this specialised type of instrument when fault finding in the field.

Diode Testing

A Diode has two resistance values, forward and reverse, These can be measured with a multimeter as shown in the diagram below.

An arrow printed on the diode body identifies the positive side of a diode.

The forward resistance is being measured in Fig. A with the positive meter lead connected to the forward side of the diode.

In Figure 'B' the meter leads have been reversed, and the reverse resistance is being measured.

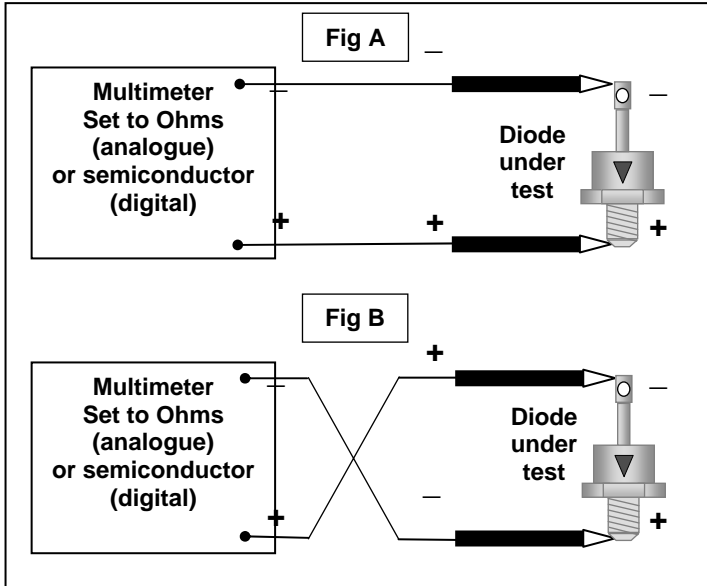

An electronic digital instrument will read true electron flow, hence the resistance polarity readings will be reverse to conventional current flow, i.e. forward and reverse readings will be reversed. A Digital Multimeter usually has a semiconductor test scale on the selector switch, marked as shown :-



This measures true electron flow, and will give a forward, (indication reading only), or reverse (no reading) indication.

Using an analogue meter on resistance scale, the forward resistance varies considerably, depending on the internal impedance of the Multimeter, and the diode type.

A typical reading would be between 20 and 100 ohms.

The reverse resistance must be very much higher, usually in excess of 100k ohms, (100,000 ohms).

A faulty diode will give a reading in both forward and reverse directions (short circuit), or no reading in either direction, (open circuit).

Simple Alternative Diode Test Circuit

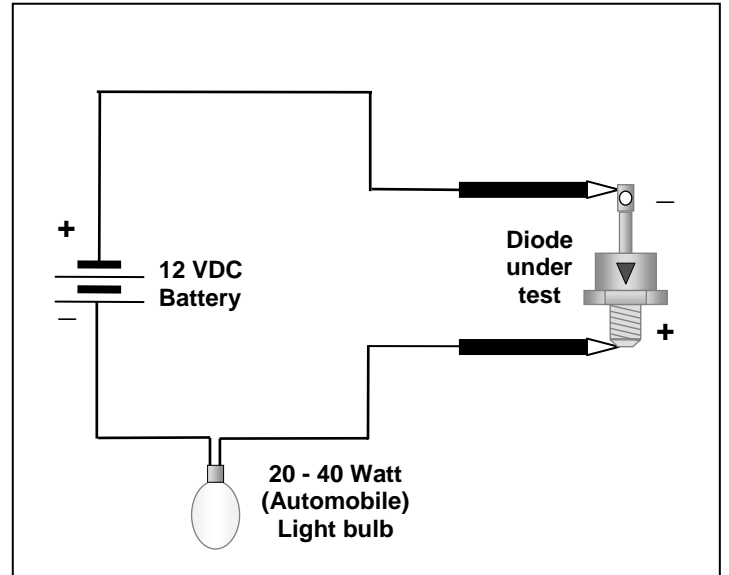

A good diode will light the bulb in only one direction. It should not light when test leads are reversed on the diode pin and base.

A faulty diode will light the bulb in both forward and reverse directions (short circuit diode), or no light in either direction, (open circuit diode).

If one or more diodes are found to be faulty, always change the complete set of diodes.

Insulation Resistance to Earth

Low Voltage Generators 100 – 690VAC.

Note

When conducting high voltage test to earth, it is advisable to either disconnect or short out any electronic devices, such as the Automatic Voltage Regulator, (AVR), and Main rotor diodes.

Short circuiting the terminals can be achieved with a piece of fuse wire, which must be removed immediately after the tests are completed.

Caution: Running the Generator before removing the short circuit connection could seriously damage the Generator.

When Megger testing a machine, failure to protect the voltage control unit and diodes could result in permanent damage to one or more of the electronic components.

The resistance of the insulation between the copper conductors and the frame of the machine, (earth or ground), is measured by means of a high voltage tester, or "Megger", which applies a D.C. potential of 500 or 1000 volts across the winding insulation.

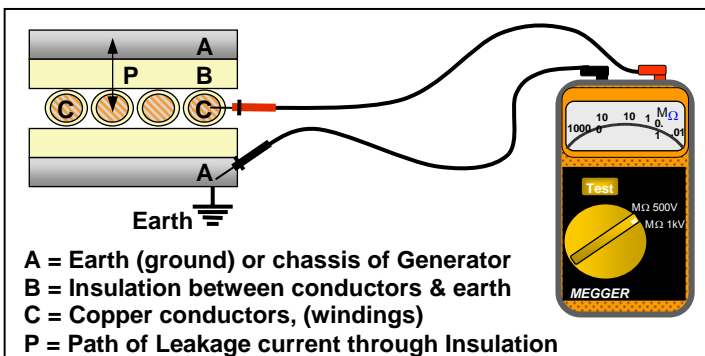
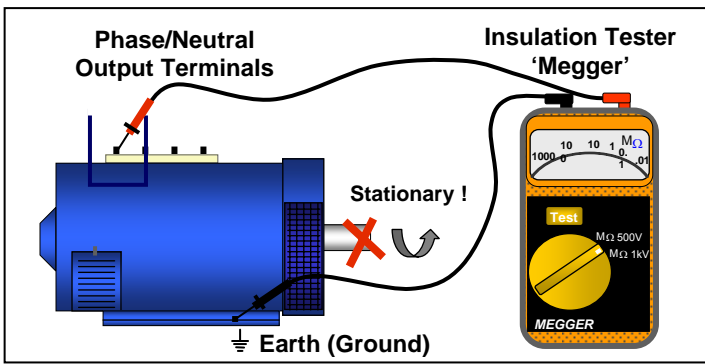

The high voltage causes a current to 'leak' through the insulation system. This current produces an output reading on the Insulation tester ('Megger'), which is measured in Megohms (resistance to earth or ground). A normal value for a low voltage Generator winding should be higher than 1 Megohm to earth.

Generators with an output voltage of between 100V to 600V should be tested as above. If the output winding (stator) is lower than 1 Megohm to earth, the windings should be cleaned, dried, or removed to a workshop for complete refurbish.

Insulation Resistance to Earth

Medium to High voltage Generators, 1k Volt or higher

High voltage generators are capable of storing a dielectric (capacitive) charge in the main stator windings, following a high voltage insulation test.



Any testing of the main stator must be followed by a discharge to earth or ground for at least 1 minute. Do not attempt to touch the main output terminals until all residual charge has been discharged.

Danger !

Insulation testing of Medium and High voltage generators .

The effectiveness of a particular on-site test will depend to a large extent on the machine application. In many situations, measurements of insulation resistance and polarisation index only will be appropriate. More detailed testing involving loss tangent, dielectric loss analysis, partial discharge measurement, is undertaken at intervals in order to establish the extent of deterioration of insulation condition. Other tests such as high voltage withstand tests are particularly effective for investigative work in order to identify the onset of fault conditions.

Polarisation Index Test (P.I.)

The P.I. test is used as a guide to the dryness, cleanliness and safety of the winding insulation system.

A special motorised insulation tester is required, which can maintain a test voltage of 1 - 2.5kV, (medium voltages), or 5kV, (high voltage), for a period of 10 minutes.

Readings are taken (in Megohms) following a 1 minute and 10 minute time interval: -

The P.I. index is obtained by the formulae:-

$$P.I. = \frac{10 \text{ Minute reading}}{1 \text{ Minute reading}}$$

The resultant ratio is called the P.I. index, and should be a minimum of 2 at 20°C.

A P.I. index below 1.5 suggests the windings are wet, dirty or faulty, and should be cleaned, dried, and refurbished as necessary.

Caution! Do not test any winding other than the main stator with this method.

SECTION 3

FAULT FINDING 'METHOD A' FOR ALL GENERATORS SEPARATELY EXCITING WITH A BATTERY

It is essential that all instruments be regularly checked for safety, and any connection leads, probes or clips checked to ensure that they are suitable for the voltage levels being tested.



Danger !

Never attempt to test a "LIVE" generator unless there is another competent person present who can switch off the power supply or shut down the engine in an emergency.

Never expose "LIVE" connections unless you have created a safe working area around you. Make sure you have made all other persons in the immediate area fully aware of what you are doing.

Caution ! Insulation Resistance to Earth

Before conducting the following tests, the Insulation of the main stator windings should be checked, in the methods described in Section 2 , 'Insulation Resistance to Earth'. Minimum Insulation to Earth for the Main Stator is 1.0 Megohm.

Fault Finding Method 'A'

Success with this method depends upon each test being completed before proceeding to the next, unless otherwise stated.

Every component in the alternator is checked regardless of the symptoms of the fault, with the exception of the voltage control system, which is covered in test Method B, Sections 4 & 5.

1. Set up for test

Disconnect the Exciter Stator leads positive and negative, from the Automatic Voltage Regulator (AVR). These terminals are marked X+ (F1), and XX- (F2), respectively.

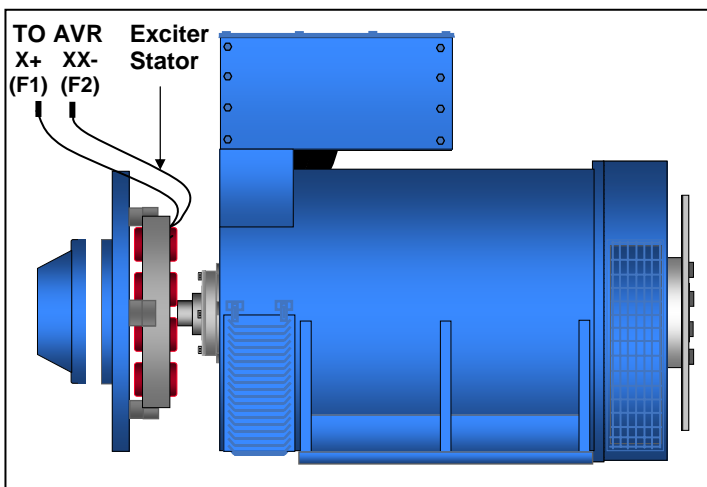

Note

Ensure that the correct two exciter leads are identified, by physically tracing them back to the exciter stator windings, fitted inside the non-drive end bracket of the Generator.

2. Check the Exciter Stator Resistance

Check the resistance value of the exciter stator across these two leads (approximately 18-30 ohms) with a Multimeter. Refer to Operation and Maintenance manual for correct values.

3. Battery Test

Connect the D.C. battery supply to the exciter stator leads, positive to X+ or orange (F1), negative to XX- or black (F2).

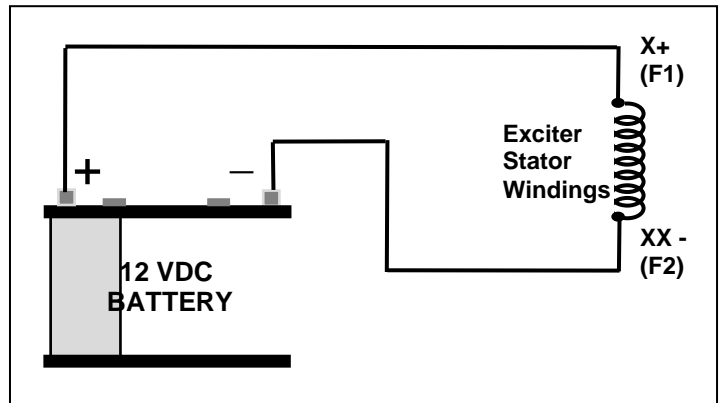

A variable source can be applied to the circuit, as shown: -

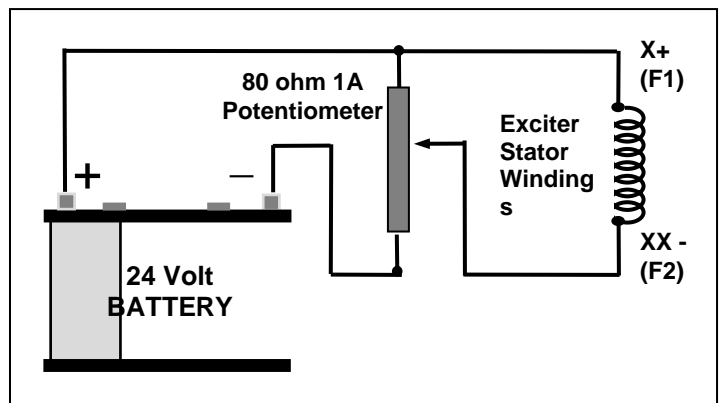

4. Run the Generator at Nominal (normal) Speed.

Ensure that the speed is within 4% of the nominal. The engine speed must be correct, to avoid misleading test results.

5. Excitation Voltage at No Load

It is essential that ALL LOAD is disconnected from the machine, and that the speed is correct.

Check the Battery Voltage after connecting to the Exciter Stator, a minimum of 12 VDC is required.

When testing with a fixed battery supply, any difference between the figures below, and the actual battery voltage, will effect the test results, and should be taken into account. For example, if your battery voltage is 10% higher or lower than the figures shown, you can expect the Generator voltage to be equally 10% higher or lower than expected.

The following chart gives the approximate D.C. battery voltages required to produce nominal output voltage $\pm 10\%$ from the Generator at no load.

FRAME SIZE	EXCITATION AT NO-LOAD
BC16 & 18	10 -12 VOLTS D.C.
UC22 & 27	10 -12 VOLTS D.C.
HC / SC 1	10 -12 VOLTS D.C.
HC / SC 2	10 -12 VOLTS D.C.
HC / SC 3	9 - 11 VOLTS D.C
C20, C30, C40	9 -11 VOLTS D.C.
HC / SC 4 , 5	10 -12 VOLTS D.C.
C45 ,C50, C60, C604	11 -12 VOLTS D.C.
HC / SC/ AC 6	12 -13 VOLTS D.C.
HC / SC / AC 7 & F8	12 -14 VOLTS D.C

6. Checking the Generator Output Voltage

Using a Multimeter, test the output voltage across the main terminals, Phase to Phase, and Phase to Neutral.

If the output voltage from the main stator is within 10% of the nominal, or higher than the nominal, and balanced across phases, this indicates that the main stator, the, main rotor, exciter stator, exciter rotor, and main rectifier diodes, are all functioning correctly.

Proceed directly to Test Number 13.

If the output is unbalanced phase to phase, or more than 10% below the nominal, this indicates that a fault exists in one of the above components, and the following tests must be conducted

7. Checking the Main Stator Winding

The voltages between phases, and each phase to neutral, should be balanced, to within 1% of the nominal voltage.

On a single-phase machine the voltage between L1-L4, and L2-L4 or U-N and W-N, must be balanced.

If the voltage is 10% or more below the nominal voltage, but is balanced within 1% phase to phase, proceed to test number 9.

If the voltage is unbalanced by more than 1%, this indicates that a fault exists with the main stator windings.

This test should be repeated with all external connections removed from the Generator terminals, to eliminate the possibility of external shorts in the output cables, or the circuit breaker.

Further tests may be made on the resistance values of the main stator windings with a Kelvin Bridge resistance test meter.

(refer to the Operation and Maintenance manual for main stator winding resistance values).

8. Symptoms of a Main Stator Fault

A fault in the main stator windings will produce short circuit currents between the coil turns in the windings.

When separately exciting with a battery, the current will also create heat in the damaged winding, which can also be heard as a slight loading of the engine.

The three fault symptoms: 1.Unbalanced Voltages. 2. Heat and/or a burning smell from the windings. 3. Engine sounds loaded, are all indications of a faulty main stator winding.

A faulty winding must be repaired or replaced.

9. Voltage is Balanced but reading Low

If the output voltage is more than 10% below the nominal voltage, but is balanced within 1% Phase to Phase, (or Phase to Neutral), the main stator is OK, but there is a fault elsewhere.

This indicates that a fault exists in either the main rotating rectifier assembly, (diodes and Varistor), or one of the excitation windings, (the main rotor, or exciter stator, or exciter rotor).

First check that the D.C. battery supply is not lower than the figure given in Paragraph 5, and that the engine speed is correct. This could give misleading results if incorrect.

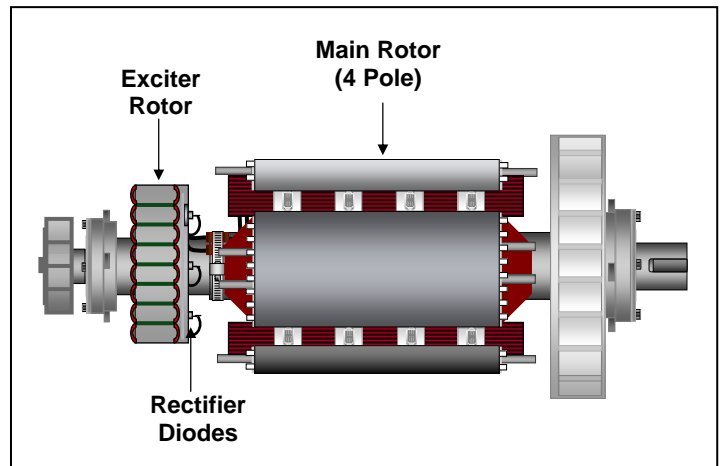

10. Testing the Rotating Rectifier Assembly

The diodes on the main rectifier assembly can be checked with a multimeter. The flexible leads connected to each diode should be disconnected at the terminal end, and the forward and reverse resistance checked. (See section 2, diode testing).

The rectifier assembly is split into two plates, positive and negative, and the main rotor is connected across these plates. Each plate carries 3 diodes, the negative plate carries the negative based diodes, and the positive plate carries the positive based diodes. Care must be taken to ensure that three identical polarity diodes are fitted to each plate. When fitting the diodes to the plates they must be tight enough to ensure a good mechanical and electrical contact, but should not be over tightened. The recommended torque tightening is 4.06 to 4.74 Nm, (14 to 17 kg/cm).

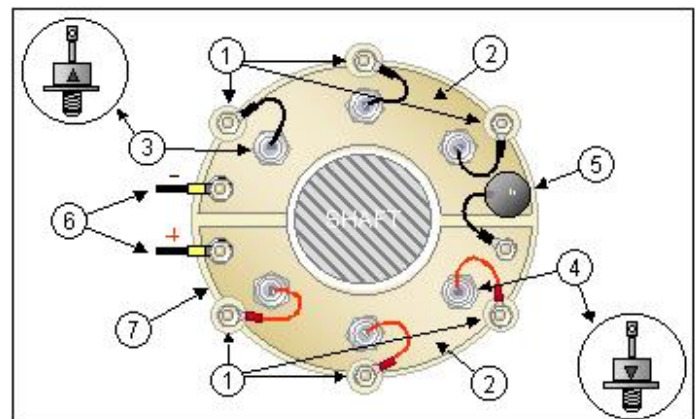

Rectifier Components

1. A.C Connection Stud
2. Rectifier Plates
3. Diodes - 3 X Negative
4. Diodes - 3 X Positive
5. Surge Suppressor (Varistor)
6. Main Rotor Leads
7. Rectifier Hub

11. Testing the Surge Suppressor (Varistor)

The Surge Suppressor (Varistor), is a protection device, which prevents high voltage transients from damaging the main rectifier diodes.

High Voltage transients are created by fault conditions in the distribution system. The Voltage transient returns back to the Generator output terminals, enters the main stator windings, and by mutual inductance, is transferred to the main rotor windings, and the main rectifier assembly.

The Surge Suppressor can be tested with a Multimeter on Megohms range.

A good Surge Suppressor should have a very high resistance, (more than 100 Megohms in either direction).

A faulty Surge Suppressor will be either open circuit (usually showing signs of burning) or short circuit in both directions.

The Main Rectifier will work normally with this device removed. However, it should be replaced as soon as possible, to avoid diode failure in the event of further transient fault conditions.

Occasionally, a very high transient may totally destroy the Surge Suppressor. This would result from extreme fault conditions, such as lightning, (electric storms), close to overhead distribution lines, or out of phase synchronisation of the Generator, when paralleled to multiple Generator systems, (or the Mains, Utility, supply).

In the event of a Surge Suppressor failure, all rectifier diodes should be replaced, including any which appear to test OK.

12. Testing the Main Excitation Windings

After establishing and correcting any fault on the rectifier assembly, the battery test should be repeated, from paragraph 6, and the output voltage checked.

If the output voltage is still more than 10% below the nominal voltage when separately excited, this indicates that the fault must be in one of the excitation windings.

To test the main rotor, exciter stator and exciter rotor winding, the resistance values must be checked against correct values, which are given in the Operation and Maintenance handbook, supplied with the generator.

Refer to the Service and Maintenance section, for the winding resistance charts, specific to each Generator type and size.

Note. The charts require identification of the frame size, number of rotor poles, followed by the main stator and rotor core length (A, B, C–G, H, J etc). The Main Stator core length and winding number are shown on the Generator nameplate.

If in doubt, refer to the factory, with the Generator serial number or machine I.D number, for identification.

Exciter Stator

The exciter stator resistance is measured across leads X+ and XX- (F1 and F2), which should be disconnected from the Automatic Voltage Regulator (AVR), terminals.

A standard Multimeter, set on the lowest resistance range, will be suitable for this test.

The exciter Stator winding Insulation to earth should also be tested with a 'Megger'. As a low insulation can effect the AVR performance. Minimum value 1 Megohm. (See section 2 for details).

Exciter Rotor

The exciter rotor is connected to the 6 X AC connection studs on the Main Rectifier assembly.

Disconnect the 6 leads from the AC connection studs, and check the resistance value across three of the leads, which are connected to the same polarity diodes, (bolted to the same rectifier plate). The resistance value is very low, and requires a Kelvin Bridge test meter for accurate results. A visual inspection will usually identify any burnt or damaged windings.

Main Rotor

The main Rotor leads are connected to the main rectifier plates. Disconnect one of the leads to check the resistance value.

A good quality Multimeter will measure resistances of 0.5 to 2 ohms with reasonable accuracy, however if the resistance is found to be lower than the quoted figure, it should be verified with a more accurate measurement.

13. Testing the AVR Sensing Supply (feedback).

Checking the sensing supply from the main stator is the final test, which can be carried out while separately exciting the Generator with a battery supply. Make sure the output voltage is approximately correct, i.e. within 10% of the nominal voltage).

The previous tests should have cleared any fault in the windings or rectifier assembly and the correct output obtained from the main stator with the battery.

With the Generator running at nominal voltage, the sensing supply should be between 190 and 240 volts. If the supply is incorrect, or unbalanced, the fault should be traced back via the wiring circuit to the Main Stator connections

Two phase sensed AVR's, MK11A, SX440, MX341, SX460, SA465

The sensing supply is across AVR terminals 2 and 3, (AVR types MX341 and SX440), or 7 and 8 (AVR types SX460 and SA465).

Note. Generators supplied before 1989. The parallel droop CT, and close regulation CT, (when fitted), is connected into the sensing supply via a burden resistor, fitted in the terminal box. Refer to the Operation and Maintenance manual supplied with the Generator for details.

Three phase sensed AVR's, MX321, MA325, MA327

The sensing supply is connected to the AVR terminals marked 6, 7, and 8.

Note 1. The Sensing Supply is connected via an isolation transformer, or an isolation module, (PCB), fitted in the Generator terminal box. Check primary and secondary of transformer, or input and output of PCB.

Note 2. Generators supplied before 1989. The parallel droop CT, and close regulation CT, (when fitted), is connected into the sensing supply via a burden resistor, fitted in the terminal box.

The sensing supply is connected via a separate 3 Phase Sensing unit, the sensing supply leads 6,7, & 8 are connected to the 3 phase sensing unit, which has a DC output to the AVR.

Refer to the Operation and Maintenance manual supplied with the Generator for details.

SECTION 4

SELF EXCITED CONTROL SYSTEM

TEST METHOD B

FAULT SYMPTOMS AND REMEDIES AT NO LOAD

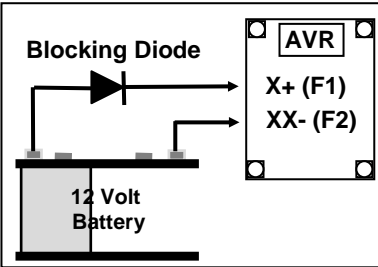
SYMPTOM	POSSIBLE CAUSE	TEST AND REMEDIES
NO VOLTAGE (NO LOAD)	1) Voltmeter connected incorrectly, or faulty.	Check and verify voltage at Generator terminals with a multimeter.
	2) Loose broken or corroded connections.	Check all auxiliary terminals. Check the AVR push on terminals for tightness. Repair or renew where necessary.
Loss of Residual Voltage 	3) Loss of residual can occur after :- (i) Many years storage prior to use. (ii) Reversal of the Exciter Stator magnetic field while 'flashing' with a battery. (iii) Rewind of the Exciter Stator. (iv) Mechanical 'shock' to the Exciter Stator laminated core, (where residual magnetism is stored). Note. Series 3 AVR systems with Permanent Magnet Generator do not rely upon residual voltage for voltage build up.	With Generator running at rated speed, without load, briefly connect a 12 volt D.C. battery supply, with a blocking diode in one lead, to AVR terminals X+ (F1) and XX- (F2).(see figure left). Maximum connection time 1 second. CAUTION! Never connect a battery to the AVR terminals, without a blocking diode. In most cases this will destroy the AVR power devices. Battery polarity MUST be correct!
NO VOLTAGE (NO LOAD)	4) Very low insulation resistance to earth (ground),on exciter stator or main stator.	Check the insulation resistance value with a Megger (see section 2). (Disconnect AVR during this test, and remove any Neutral earth connection).
	5) Surge suppressor on main rotating rectifier short circuit.	Check surge suppressor resistance (see Section 3 Test Method A).
	6) Main rectifier diode(s) short circuit.	Carry out Test Method A, Section 3. Replace where necessary. Check diodes (See Section 2)
	7) Winding fault. Open circuit or short circuit on any winding in the machine.	Carry out all tests as listed in Test Method A. Check winding resistance values.
	8) Exciter stator polarity reversed by battery tests. Also see "Loss of Residual Voltage" which may be caused by polarity reversal.	Re-connect battery to exciter stator ensuring that polarity is correct, and re-test. Restore residual magnetism as Item 3 above.
	9) Fault in AVR.	Replace the AVR and re-test machine.
	10) Load applied to machine during run up of engine.	The voltage may not build up until the load is disconnected from the machine. Open circuit breaker and re-test.
	11) Open circuit power supply from main stator to AVR terminals P2, P3, P4. (SX440), or 7 and 8 (SX460 and SA465).	Separately excite machine as per test method A, Section 3. Check voltage across AVR terminals P2, P3, P4, or 7 & 8. AVR power supply should be between 190 to 240VAC.

SYMPTOM	POSSIBLE CAUSE	TEST AND REMEDIES
LOW VOLTAGE (NO LOAD)	1) Engine speed low. Under frequency protection (UFRO) circuit activated.	Check AVR LED. If lit, UFRO is activated, indicating low speed. Check speed with tachometer. Adjust governor control to nominal speed, or up to maximum (+4%) of nominal speed.
	2) AVR 'VOLTS' adjust, or external hand trimmer control incorrectly set.	Adjust voltage on AVR 'volts' trim, or remote trimmer. Ensure that speed is correct, and UFRO is OFF. (See above).
	3) Voltmeter faulty or sticking.	Check and verify voltage across machine output terminals, with a Multimeter.
	4) Fault in AVR.	Replace AVR and re- test.
	5) Loose broken or corroded connections.	Check the wiring for poor connections. Repair or replace where necessary.
	6) Fault on power supply from main stator.	See item 11, previous test under "No voltage, at no load".
HIGH VOLTAGE (NO LOAD)	1) Sensing supply from Main Stator to AVR open circuit or too low.	Check sensing supply voltage, as per Test Method A, Section 3, (item 13).
	2) AVR 'VOLTS' control or hand trimmer incorrectly set.	Adjust as necessary. Ensure that the engine speed is correct first.
	3) Sensing supply transformer faulty.	AVR sensing supply circuit via dropper transformer, (4 or 6 wire Generators), or sensing PCB. Check sensing supply as per Test Method A, Section 3, (item 13).
	4) Burden resistor, fitted in AVR sensing supply, corroded or open circuit. (Pre 1987 Generators only.)	A fault on the burden resistor can create a high voltage condition. Check tapping bands. Normal resistance value 215 ohms.
	5) AVR faulty.	Replace AVR and re-test.
	6) Loose, broken or corroded connections.	Check connections on auxiliary terminal board and AVR terminals. Repair or replace if necessary.
UNSTABLE VOLTAGE (NO LOAD)	1) Engine governor unstable (hunting).	Check for speed instability with a frequency meter, or tachometer. Sometimes this problem will clear when a load is applied to the engine.
	2) AVR Stability settings.	Check AVR stability links, adjust stability potentiometer.
	3) Loose or corroded connections.	Intermittent voltage fluctuations can be created by poor connections. Check auxiliary and AVR terminals.
	4) Intermittent earth (low insulation resistance).	Megger all windings, (see section 2), including Exciter Stator, low insulation resistance can effect the AVR.
	5) Faulty AVR.	Check AVR for corrosion or broken components. Replace AVR and re-test
	6) Voltmeter faulty/unstable.	Panel mounted voltmeters are sensitive to vibration. Check and verify readings.
UNBALANCED VOLTAGE (NO LOAD).	1) Fault on main stator windings.	Disconnect all external leads to Generator and re-test. Separately excite, (Test Method A Section 3). A winding short will get hot, and engine will sound slightly loaded. Shut down set and check by hand for hot spots.

FAULT SYMPTOMS AND REMEDIES WHEN ON LOAD

SYMPTOM	POSSIBLE CAUSE	TEST AND REMEDIES
UNBALANCED VOLTAGE (ON LOAD).	1) Single-phase loads (phase - neutral) unevenly distributed over the three phases.	Check current in each phase with clip-on ammeter. The full load rated current must NOT be exceeded on any individual phase. Re-distribute load if necessary.
UNSTABLE VOLTAGE (ON LOAD).	1) Engine governor unstable (hunting)	Check with a frequency meter or tachometer for speed variations due to governor 'hunting', or cyclic irregularities in the engine.
	2) Leading Power Factor load created by power factor correction capacitors.	Isolate the power factor correction capacitors until sufficient inductive load has been applied. (See Power Factors, Section 2).
	3) Fluctuations in load current, (motor starting, or reciprocating loads).	Check the load current on a stable supply, i.e. mains, or separately excite the machine. A variable D.C. supply is required for on load separate excitation tests. (see test method A, section 3).
	4) Non linear load creating waveform distortion. (Contact factory for further information on non-linear loads).	Use Permanent Magnet Generator (PMG), powered control system (AVR).
	5) AVR stability incorrectly adjusted.	Adjust AVR, until voltage stabilises.
HIGH VOLTAGE (ON LOAD)	1) Unbalanced load.	Check voltages on all phases. If unbalanced, re-distribute loading over three phases.
	2) Leading Power Factor load (capacitor banks).	Check excitation volts across X+, (F1) and XX- (F2). A leading power factor will give an abnormally LOW DC excitation. Remove power factor correction equipment at low loads (see Power Factors Section 2).
	3) Parallel droop current transformers reversed.	Check for droop reversal. (See section 6, parallel operation).
	4) Burden resistor incorrectly set across improved regulation transformer. (Pre 1989 machines only).	Reduce the amount of resistance across the improved regulation transformer until on-load voltage is correct.
POOR VOLTAGE REGULATION (ON LOAD)	1) Large speed droop on engine. AVR UFRO protection activated.	Check that the speed droop from no load to full load is no greater than 4%. Check AVR LED, if LIT, increase engine speed.
	2) Unbalanced load.	Check voltage and load current on all phases. If unbalanced, redistribute the load more evenly across the phases.
	3) Parallel droop circuit incorrectly adjusted, or requires shorting switch for single running.	The droop circuit will give additional voltage droop of $-2\frac{1}{2}$ % at full load 0.8 pf. For single running machines this can be improved by fitting a shorting switch across the droop CT input, (S1 – S2), on the AVR. (Pre 1989 machines, short across the burden resistor in the terminal box).
	4) Voltage drop between machine and load, due to I^2R losses in supply cable. (This will be made worse by motor starting current surges, etc).	Check the voltage at both ends of the cable run at full load. Differences in voltage indicates a volts drop along the cable. In severe cases, a larger diameter cable is required.
	5) Improved regulation equipment reversed. (Pre 1989 machines only).	Reverse the secondary leads on the transformer, and re-test on load.

SYMPTOM	POSSIBLE CAUSE	TEST AND REMEDIES
POOR VOLTAGE REGULATION cont.. (ON LOAD)	6) Fault on main rectifier or excitation windings.	Check the no-load excitation volts across AVR X+ (F1) and XX- (F2). Compare with the D.C. voltages as listed in Test Method A Section 3. If much higher than listed, carry out Test Method A.
	7) AVR Under frequency protection circuit, (UFRO), activated.	Check AVR LED, If lit, UFRO is activated, (engine speed is low). Check engine speed and adjust to correct nominal speed, (or frequency).
POOR VOLTAGE RESPONSE TO LOAD SURGES OR MOTOR STARTING	1) Engine fault or engine governor unable to respond, (speed drop too low).	Check performance of engine during application of load. Check if AVR LED is lit during motor starting. Check if AVR 'DIP' or 'DWELL' engine relief circuits are activated. Adjust as necessary. (See AVR instruction sheet for details).
	2) Parallel droop circuit incorrectly set.	Too much droop will increase voltage dips when motor starting. Fit shorting switch for single running Generators. (See parallel section 6).
	3) Load surges exceed 2.5 times the full load current.	Check load surges with a clip-on ammeter. Voltage dip may be excessive if the current exceeds 2.5 times full load. Refer to factory for motor starting calculations.
	4) Voltage drop between Generator and load, due to I^2R losses in the cable. This will be worse during current surges (motor starting etc).	Check the voltage at both ends of the cable run at full load. Differences in voltage indicates a volts drop along the cable. In severe cases, a larger diameter cable is required.
	5) Motor contactors dropping out during starting, (large current surges, Voltage dips greater than 30%).	All symptoms and remedies in this section may apply to this problem. Refer to factory for typical voltage dips.
	6) AVR "Stability" control incorrectly adjusted.	Adjust AVR 'Stability' control anticlockwise until voltage is unstable, then slightly clockwise until stable.
	7) Fault on windings or rotating rectifier.	Any fault in this area will appear as high excitation voltage across X+ (F1) and XX- (F2), higher than figures listed in Section 3. Complete Test Method A Section 3
	8) AVR UFRO and/or engine relief circuit activated during motor starting.	Check performance of engine during application of load. Check if AVR LED is lit during motor starting. Check if AVR 'DIP' or 'DWELL' engine relief circuits are activated. Adjust as necessary. See AVR instructions for details.
	9) Faulty AVR.	Replace and re-test on load.

SYMPTOM	POSSIBLE CAUSE	TEST AND REMEDIES
LOW VOLTAGE (ON LOAD)	1) Engine speed droop greater than 4%.	Check if AVR LED is lit, UFRO is activated, (low speed indication). Check engine speed no load and full load. Engine governing should be within + 4% and -1% of nominal speed. Reset as necessary.
	2) Under frequency protection circuit operational (UFRO).	Check AVR LED. If lit, UFRO is activated, increase engine speed to correct levels.
	3) Fault in AVR power supply from main stator.	Separately excite machine as per test method A, Section 3. Check voltage across AVR terminals P2, P3, P4, or 7 & 8. Normal AVR power supply should be between 190 to 240VAC.
	4) AVR faulty.	Replace AVR and re-test.
	5) Fault on winding or rotating diodes.	Any fault in this area will appear as high excitation voltage across X+ (F1) and XX- (F2), higher than figures listed in Section 3. Complete Test Method A Section 3
	6) Voltage drop between Generator and load, due to I^2R losses in the cable. This will be worse during current surges (motor starting etc).	Check the voltage at both ends of the cable run at full load. Differences in voltage indicates a volts drop along the cable. In severe cases, a larger diameter cable is required.

SECTION 5

SEPARATELY EXCITED CONTROL SYSTEM WITH PERMANENT MAGNET GENERATOR (PMG)

The Permanent Magnet Generator (PMG)

The PMG rotor shaft is located onto the non-drive end of the Generator shaft. A spigot fits over the shaft end, and the whole assembly is secured by a single bolt through the PMG rotor, into a threaded hole in the shaft.

The PMG stator is fitted to the non-drive end bracket of the Generator, either directly into a spigot on the non-drive end bracket, or bearing cap, or into a housing as shown below.

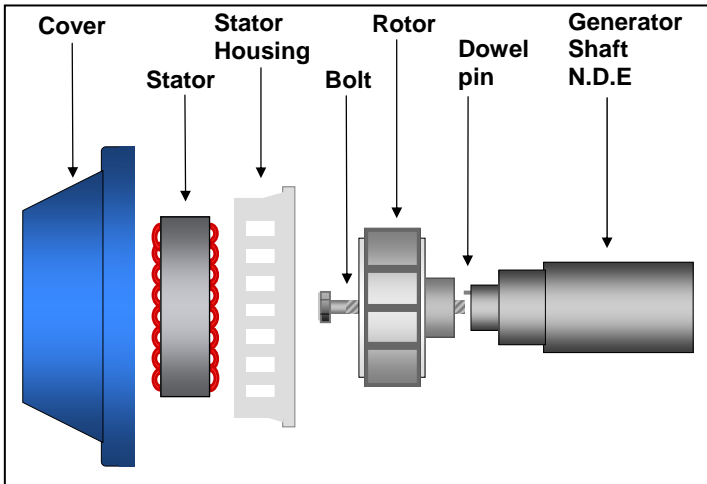
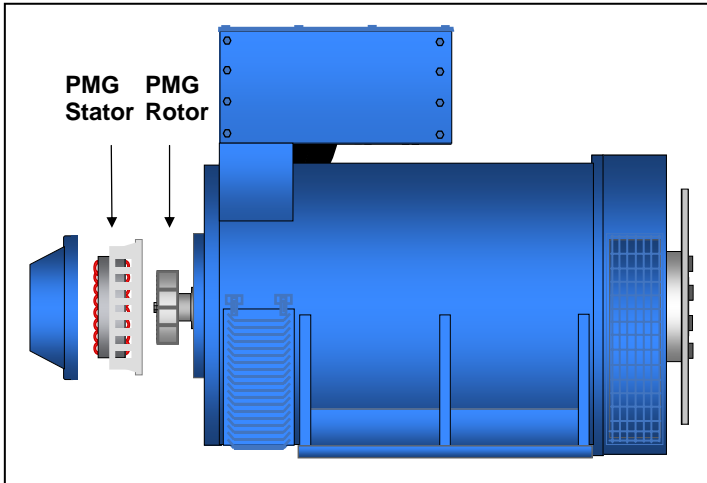

PMG powered AVR's (Series 3)

The PMG provides an independent power supply for the Automatic Voltage Regulator (AVR).

Series 3 (PMG Excited), AVR types are designated 'MX' or 'MA', to identify them as PMG powered AVR's.

Series 4 (Self-Excited), AVR types are designated 'SX' or 'SA', and are unsuitable for use with a PMG power supply.

Testing the Permanent Magnet Generator

The PMG can be tested as an independent Generator.

Disconnect the AVR power supply leads marked P2, P3, P4, from the AVR terminals.

Run the Generator at nominal speed (the speed must be correct for accuracy of results).

Check the PMG output Voltage across leads P2, P3, and P4 with a multimeter, set to AC volts.

For 50 Hz Generators, Voltage across P2, P3 and P4 should be approximately 170VAC.

For 60Hz Generators, Voltage should be approximately 200VAC.

PMG's manufactured before 1983.

The PMG stator has a lead marked P1, which is the Neutral connection. The Voltage from P1, (Neutral), to P2, P3, and P4 should be $1/1.732$ of the phase to phase voltage.

Note: This lead is not required for later AVR types, and can be removed if the original AVR is replaced.

Series 3 AVR's manufactured before 1989

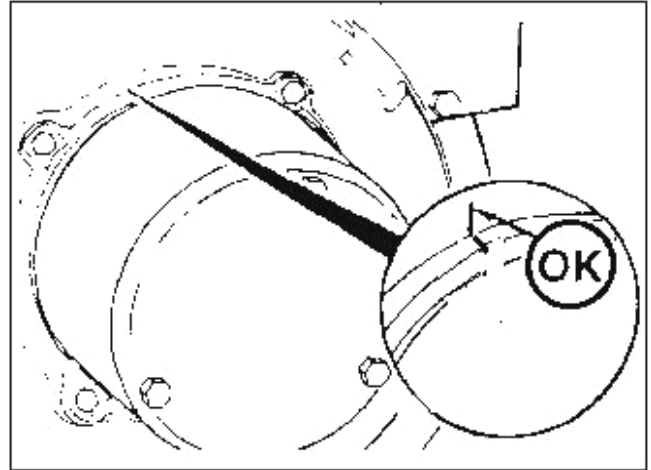

The radial position of the PMG Stator was important for adjustment of the AVR response and regulation.

For Pre-1989 Generators, the PMG stator is fitted into a housing, which is clamped to the Generator non-drive end bracket.

Release of the clamps allows the PMG stator housing to be rotated in its spigot.

The correct radial position of this housing is marked at the top, (12 O'clock position), on the housing and end bracket.

When work is carried out which requires the dismantling of the PMG, care should be taken during re-assembly, to ensure that the PMG stator is returned to its original radial position.

NOTE: Series 3 AVR's manufactured after 1989

If the original pre-1989 AVR is changed for a later model, the radial position of the PMG Stator is not important.

SECTION 5
SEPARATELY EXCITED CONTROL SYSTEM
WITH PERMANENT MAGNET GENERATOR (PMG)
TEST METHOD B
FAULT SYMPTOMS AND REMEDIES AT NO LOAD

SYMPTOM	POSSIBLE CAUSE	TEST AND REMEDIES
NO VOLTAGE (NO LOAD)	1) Faulty permanent magnet generator (PMG), stator or rotor.	<p>Disconnect the PMG leads from AVR terminals P2, P3, P4. Check voltage across leads with a Multimeter, with the set running at correct speed. For 50Hz, Voltage across P2, P3 and P4 should be approx. 170VAC. For 60Hz, Voltage is approx. 200VAC.</p> <p>Pre 1983 machines. Lead P1 from the PMG is the Neutral. Voltage P1 to P2, P3, & P4 should be 1/1.732 of phase to phase voltage.</p>
	2) Insulation failure to earth, (ground), on permanent magnet stator.	Disconnect leads P2, P3, P4 and, 'Megger' test to earth, (see Section 2).
	3) Voltmeter faulty.	Check and verify voltage at Generator output terminals with a Multimeter.
	4) Loose, broken or corroded connections.	Check connections, repair and replace where necessary.
	5) AVR High excitation protection circuit activated, collapsing output voltage. (AVR protection circuit is factory set to trip at 70VDC across AVR output).	<p>Check if AVR LED is LIT, indicating protection circuit activated. Shut down the engine, and run up again. If the voltage builds up normally but collapses again, the protection circuit has operated, & AVR LED will be lit. Run again & check the excitation voltage across A.V.R X+ (F1) and XX- (F2). If greater than 70 VDC, the protection circuit is operating correctly. Carry out Test Method A, Section 3, to establish cause of high excitation volts.</p>
	6) Main Rectifier diodes short circuit.	Check diodes (see Section 2). Carry out Test Method A Section 3.
	7) Open circuit in exciter stator windings.	Remove external leads from Generator, and carry out all tests as per Test Method A, Section 3.
	8) Faulty AVR .	Replace AVR and re-test..
	9) Winding fault, open circuit or short circuit.	Remove external leads from Generator, and carry out all tests as per Test Method A, Section 3.

SYMPTOM	POSSIBLE CAUSE	TEST AND REMEDIES
LOW VOLTAGE (NO LOAD)	1) Engine speed low	Check LED on AVR. If lit, UFRO protection is activated, indicating low engine speed. Adjust engine speed to correct nominal.
	2) Under frequency protection (UFRO) circuit operational.	Check if LED on AVR is lit, indicating low engine speed. Adjust engine speed to within -1% to +4% of nominal.
	3) Voltmeter faulty or 'sticking'.	Verify voltage across Generator output terminals with a Multimeter
	4) AVR 'VOLTS' adjust incorrectly set	Adjust control CLOCKWISE to increase voltage. If remote hand trimmer fitted, adjust in conjunction with trimmer.
	5) Faulty AVR	Replace AVR and re-test.
HIGH VOLTAGE (NO LOAD)	1) AVR 'VOLTS' adjust or remote trimmer incorrectly set.	Check and adjust as necessary.
	2) Low sensing supply from main stator.	Check sensing supply as per Test method A Section 3, paragraph 13.
	3) Sensing supply open circuit to AVR terminals 2 and 3, (AVR MX341), or 6, 7 & 8, (MX321, and all MA type).	Open circuit or low sensing signal will cause the AVR to produce high excitation, which will produce a high output Voltage. Check sensing supply as per Test method A, Section 3, paragraph 13.
	4) Burden resistor open circuit. (Pre 1989 machines only).	Disconnect burden resistor, (fitted in terminal box), and check resistance (215 ohms). Also check tapping bands and connections for corrosion and tightness.
	5) Faulty AVR.	Replace AVR and retest machine
UNSTABLE VOLTAGE (NO LOAD)	1) Engine speed 'hunting' (unstable).	Check with a frequency meter or tachometer for speed variations due to governor 'hunting', or cyclic irregularities in the engine. This may improve as load is applied.
	2) Permanent magnet stator incorrectly positioned. (Pre 1989 AVR only).	The radial position of the stator housing is important for the stability and response of the AVR. (See start of Section 5 for details). Later AVR models do not require this adjustment.
	3) AVR stability control incorrectly adjusted.	Adjust stability clockwise until voltage stabilises. Check again on load.
	4) Loose or corroded connections.	Check push on terminals on AVR Check auxiliary terminals for loose connections. Repair or replace as necessary.
	5) Intermittent earth on machine.	Megger all windings, (see section 2), including Exciter Stator, low insulation resistance can effect the AVR.
UNBALANCED VOLTAGE (NO LOAD)	1) Fault in main stator winding.	Disconnect all external leads to Generator and re-test. Separately excite Generator, (Test Method A Section 3). A winding short will get hot, and engine will sound slightly loaded. Shut down set and check by hand for hot spots.

FAULT SYMPTOMS AND REMEDIES WHEN ON LOAD

SYMPTOM	POSSIBLE CAUSE	TEST AND REMEDIES
UNBALANCED VOLTAGE (ON LOAD)	1) Single-phase load current unevenly distributed over the three phases.	Check the current in each phase with clip-on ammeter. The full load rated current must not be exceeded on any one (single) phase. Re-distribute load if necessary.
UNSTABLE VOLTAGE (ON LOAD)	1) Engine governing unstable (hunting)	Check with frequency meter or tachometer for engine governor 'hunting', or cyclic irregularities in the engine.
	2) Leading power factor load created by power factor correction capacitors.	Isolate the power factor correction capacitors until sufficient motor load has been applied to counteract the leading power factor. (See Power Factors Section 2.)
	3) Permanent magnet stator positioned incorrectly (Pre 1989 AVR's only).	The radial position of the stator housing is important for the stability and response of the AVR. Later AVR models do not require this adjustment. (see start of this section for details.
	4) Non linear loads, causing interaction between dynamic closed loop control systems.	Interaction of closed loop systems controlling the load, the generator, and the engine. Instability caused by oversensitive control settings. Adjust AVR to high gain, (stability), and load drives to low gain. Increase engine speed 'droop' to reduce sensitivity. Contact factory for further advice regarding non-linear loads.
	5) Fluctuations in load current, (motor starting, or reciprocating loads).	Check the load current on a stable supply, i.e. mains, or separately excite the machine. A variable D.C. supply is required for on load separate excitation tests. (see test method A, section 2).
	6) AVR stability control incorrectly adjusted.	Adjust AVR control, until voltage is stable
POOR VOLTAGE REGULATION (ON LOAD)	1) Large speed droop on engine. AVR UFRO protection activated.	Check that the speed droop from no load to full load is no greater than 4%. Check AVR LED. If LIT, increase engine speed.
	2) Parallel droop circuit incorrectly adjusted, or requires shorting switch for single running.	The droop circuit will give additional voltage droop of -2½ % at full load 0.8 pf. For single running machines this can be improved by fitting a shorting switch across the droop CT input, (S1 – S2), on the AVR. Pre 1989 machines. Short across the burden resistor in the terminal box. (See section 6 parallel operation).
	3) Unbalance load.	Check voltage and load current on all phases. If unbalanced, redistribute the load more evenly across the phases.
	4) AVR stability adjustment incorrectly set.	Adjust 'stability' anticlockwise until voltage becomes unstable. Adjust slightly clockwise until voltage stabilises.

SYMPTOM	POSSIBLE CAUSE	TEST AND REMEDIES
POOR VOLTAGE REGULATION cont. (ON LOAD)	5) Voltage drop between Generator and load, caused by losses in supply cable, (I^2R losses).	Check the voltage at both ends of the cable run at full load. Large differences in voltages indicate a large volts drop along the cable. A larger diameter cable is required in severe cases.
	6) Fault on main rectifier or excitation winding.	Check the no load excitation voltage across AVR X+ (F1) and XX- (F2). If higher than 12 volts D.C. the machine must be tested as per Section 3 Test Method A.
	7) Under frequency protection (UFRO) activated.	Check LED on AVR. If lit, UFRO is activated. (engine speed is too low). Check speed and adjust to nominal.
	8) Permanent Magnet stator position incorrect. (Pre 1989 AVR' s only).	The radial position of the stator housing is important for the regulation, and response of the AVR. (see start of section 5 for details).
POOR RESPONSE TO LOAD SURGES OR MOTOR STARTING	1) Engine governor sticking or slow to respond. AVR 'UFRO' protection circuits activated.	Check performance of engine during application of load. Check if AVR LED is lit during motor starting. Check if AVR 'DIP' or 'DWELL' circuits are activated. Adjust or de-activate, (See AVR instruction sheets).
	2) Parallel droop circuit incorrectly set.	Too much droop will increase voltage dips when motor starting. Fit shorting switch for single running Generators. Adjust droop, (See Parallel section 6) if necessary.
	3) Load current surges exceed 2.5 times full load of the machine.	Check surges with clip-on ammeter. Check with Stamford factory for advice on voltage dips for motor starting.
	4) UFRO protection on AVR operational.	Check engine speed DIP on load application. Check LED on AVR. Low engine speed will activate UFRO protection circuit. (LED ON).
	5) Voltage drop between Generator and load, caused by I^2R losses in supply cable. This will be worse during current surges, (motor starting etc).	Check the voltage at both ends of the cable run at full load. Differences in voltages indicate a Volts drop along the cable. A larger diameter cable may be required in severe cases.
	6) Incorrect position of permanent magnet stator (Pre 1989 type A.V.R.'s only).	The position of the PM Stator affects the response performance of the AVR See following text for details.
	7) Motor contactors dropping out due to voltage dip on starting.	All symptoms and Remedies in this section may apply to this problem. Refer to factory for voltage dip calculations.
	8) AVR 'Stability' controls incorrectly set.	For best performance, adjust 'Stability' control anticlockwise until voltage is unstable, then slightly clockwise, until stable.
	9) Fault on windings or rotating rectifier.	Check the no load excitation voltage across AVR X+ (F1) and XX- (F2). If much higher than 12 volts D.C. the machine must be tested as per Section 3 Test Method A.
	10) Engine relief circuits in AVR activated.	Check if AVR has "DIP" or "DWELL" circuits. Adjust or turn out control if affecting load response.
	11) Fault in AVR.	Replace and test on load.

SYMPTOM	POSSIBLE CAUSE	TEST AND REMEDIES
VOLTAGE COLLAPSES (ON LOAD)	1) Protection circuit in AVR activated, due to high excitation condition across AVR output, (X+ (F1) and XX- (F2)).	Excitation volts higher than 70V D.C. Check across X+ (F1) and XX- (F2) on load. Ensure engine speed is correct at full load. Check output voltage, ensure it does not exceed the rated voltage. Check load current for overload.
	2) Protection circuit in AVR operated, due to fault in Generator windings or diodes.	Check AVR LED, if lit, protection circuit is activated. Shut down engine, and re-start. If voltage returns as normal, but collapses again on load, protection circuit is activated, due to high excitation. Carry out tests as per Test Method A Section 3, to identify cause of high excitation volts.
	3) Malfunction of protection circuit in AVR.	Replace AVR and test on load.
	4) Severe overload or short circuit on across phases.	Check load current with clip-on ammeter.
HIGH VOLTAGE (ON LOAD)	1) Unbalanced load.	Check voltage on all three phases. If unbalanced, re-distribute loading over the three phases.
	2) Leading Power Factor Load.	Check for capacitive (leading) PF load, i.e. kVAr correction, fluorescent lights. Apply motor (lagging) PF load, or switch off capacitors. A leading power factor load will give abnormally low D.C. excitation volts across X+ (F1) and XX- (F2).
	3) Parallel droop transformer reversed, (when fitted).	Check for reversal of droop CT, P1 - P2 or S1 - S2, reverse either to correct. See section 6 for more details.
LOW VOLTAGE (ON LOAD)	7) Engine speed droop greater than 4%.	Check if AVR LED is lit, UFRO is activated, (low speed indication). Check engine speed no load and full load. Engine governing should be within + 4% and -1% of nominal speed. Reset as necessary.
	8) Under frequency protection circuit operational (UFRO).	Check AVR LED. If lit, UFRO is activated, increase engine speed to correct levels.
	9) Faulty permanent magnet generator (PMG) stator or rotor.	Disconnect the PMG leads from AVR terminals P2, P3, P4. Check voltage across leads with a Multimeter, with the set running at correct speed. For 50Hz, Voltage across P2, P3 and P4 should be approx. 170VAC. For 60Hz, Voltage is approx. 200VAC.
	10) AVR faulty.	Replace AVR and re-test.
	11) Fault on winding or rotating diodes.	Any fault in this area will appear as high excitation voltage across X+ (F1) and XX- (F2). If higher than figures listed in Section 3. Carry out Test Method A Section 3.
	12) Voltage drop between Generator and load, due to I^2R losses in the cable. This will be worse during current surges (motor starting etc).	Check the voltage at both ends of the cable run at full load. Differences in voltage indicates a volts drop along the cable. In severe cases, a larger diameter cable is required.

SECTION 6

PARALLEL OPERATION OF A C GENERATORS

It is essential that all instruments be regularly checked for safety, and any connection leads, probes or clips checked to ensure that they are suitable for the voltage levels being tested.



Danger !

Never attempt to test a "LIVE" generator unless there is another competent person present who can switch off the power supply or shut down the engine in an emergency.

Never expose "LIVE" connections unless you have created a safe working area around you. Make sure you have made all other persons in the immediate area fully aware of what you are doing.

1. Introduction and theory

This section will explain the reasons for paralleling, the method by which it is carried out, the setting up procedures and possible problems that may arise.

Parallel Operation may be necessary for the following reasons:-

- (1) To increase the capacity of an existing system.
- (2) Size and weight may preclude the use of one large unit.
- (3) Allows non-interruption of the supply when servicing is required.

In order to parallel AC Generators satisfactorily, certain basic conditions have to be met. These are as follows:-

- (1) All systems must have the same voltage.
- (2) All systems must have the same phase rotation.
- (3) All systems must have the same frequency.
- (4) All systems must have the same angular phase relationship.
- (5) Systems must share the load with respect to their ratings.

Metering and Protection

A minimum amount of instrumentation is required to ensure the above information is satisfactorily monitored, comprising an ammeter, a wattmeter and a reverse power relay. No voltmeter is specified for each system because it is preferred to use one voltmeter on the distribution or synchronising panel with a selector switch for each system. This eliminates any possible meter inaccuracies.

A reverse power relay is essential as any engine shut down, from low oil pressure or temperature etc. will result in other systems motoring the failed set, with consequent overload to the remaining systems, and/or damage to the motored engine.

Only one frequency meter is required with the facility of being switched to the busbar, or the incoming system.

Synchronising

A synchroscope and/or lights, is required to detect the angular phase displacement. If lights are used three different connections are possible. For paralleling with the lights dim, they must be connected across like phases or like lines (single phase), i.e. UU, V-V or L1-L1. For paralleling with lights bright they should be connected across unlike phases, i.e. U-V etc.

If a three-lamp system is used with the lamps connected across U-W, V-V and W-U the lamps will 'rotate' and give an indication which machine is running fast. Synchronism is reached with two lamps bright and one dark and in some respects this connection gives a closer visual indication of the point of synchronism. Note the lamps should be rated for at least twice the machine voltage or it will be necessary to connect two or three in series. A more preferred method is a resistor, in series with each lamp.

The following diagrams illustrate the connections:

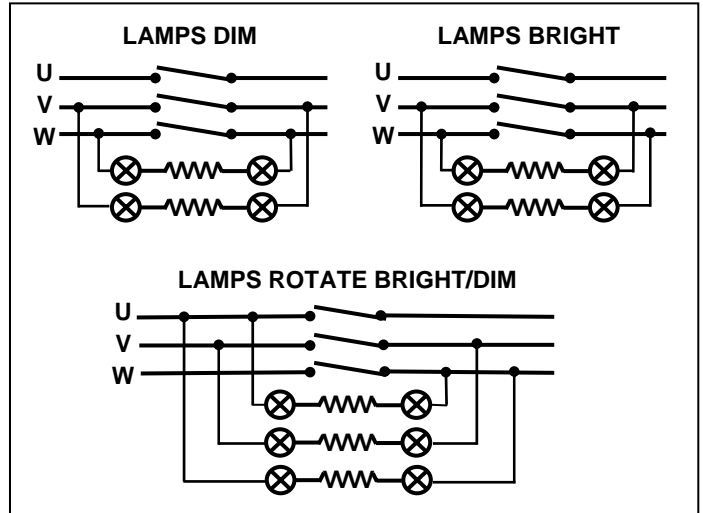

NOTE: If the neutral is solidly linked, then only one set of lamp/resistors is required, because the return path is through the neutral link. This, of course, only applies to the lamps dim or lamps bright connection, and not on the three lamp connection.

Modern installations prefer to use semi or fully automatic synchronising equipment, which allows breaker closure only when conditions are correct.

Load sharing

An important aspect of parallel operation is load sharing. The total load, comprising a kW or active component and a kVAR or reactive component, must be shared by the systems with respect to their normal ratings.

The kW component is adjusted by purely mechanical means and requires relatively fine speed control of the prime mover (engine). It is advisable to fit a limited range governor to avoid large adjustments of speed when in parallel.

The kVAR component is a function of the AC generator excitation. When machines are in parallel, the magnitude of the field excitation will not directly influence the output voltage, (depending upon the relative size of the Generator to the bus-bar system) it does however, adjust the internal power factor at which a particular machine operates. For instance, an over-excited AC generator will produce a lagging pf current from that Generator. If a difference in excitation exists, then circulating currents will flow, limited only by the internal machine reactance. This current will appear as a zero p.f. leading or lagging current, depending on the machine excitation, and will either subtract or add to the total current that each machine supplies. Reactive current, either leading or lagging, is by virtue of the 90-degree phase displacement, quite commonly described as being quadrature.

The Generators must therefore be provided with equipment to sense this reactive current, and limit it to an acceptable level. Hence the quadrature droop Current Transformer, which is connected to the AVR sensing terminals S1-S2.

Note: For correct operation, it is essential that the droop CT primary conductor is Fitted into the correct phase, (usually 'W' for 3 phase Generators), and in the correct polarity.

The secondary output leads S1 –S2, must also be connected in the correct polarity.

(Pre 1989 machines). The droop CT is connected in parallel with a burden resistor or choke, external to the AVR, and in series with the AVR sensing supply.

2. General notes on setting up procedure

Stable parallel operation and accurate load sharing between no load and full load can only be obtained when the initial voltage settings and droop kits are correctly set up. It is also most important the engine governor characteristics are similar otherwise incorrect kW load sharing can result when either increasing or reducing load.

To check the no load voltage settings, run each machine singly at the normal no load frequency, i.e. 52Hz for 50Hz operation or 62Hz for 60Hz operation. The rated voltages should now be set to within ½% of each other. Remote hand trimmers can be fitted to the control panel for this purpose.

Quadrature droop equipment

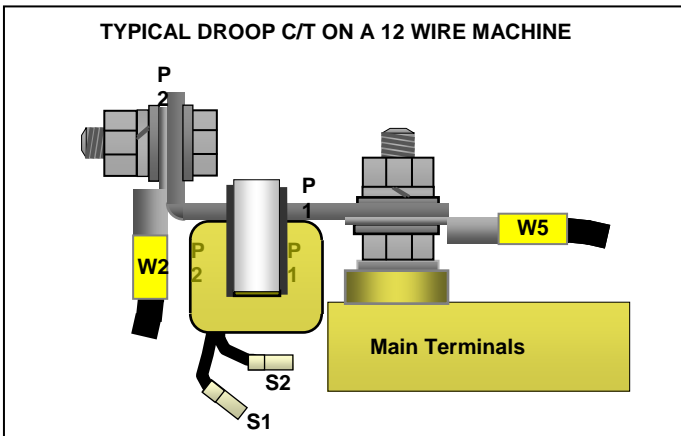
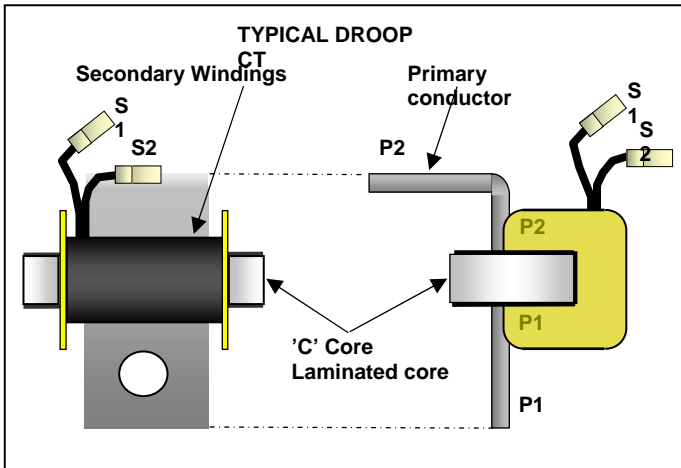

The most important aspect of initial setting up procedure concerns the droop circuit. Most of the troubles allied to poor parallel operation originate from the droop circuit. They are either incorrectly adjusted for the level of voltage droop, or are incorrectly connected, such that a rising voltage characteristic is obtained.

If a machine is specified for parallel operation at the time of ordering, then the droop kit supplied will have been set up on test.

Provided that the terminal markings and connections are followed, no problem should result.

Caution! Reversal of the transformer or reversal of the secondary connections to the transformer will result in a rising voltage characteristic, which is completely unstable during parallel operation. In this condition very high circulating current will be produced by the generators.

Where machines have to be modified to incorporate a droop CT at a later date, ensuring a drooping voltage characteristic appears to be of the greatest difficulty. As previously stated, the droop is correctly adjusted when the terminal voltage droops 5% with zero pf, or 3% when the generator is at full load 0.8 PF.

Testing the parallel droop circuit for reversal

1. Adjust the AVR droop control to put the maximum amount of droop in circuit. (Pre 1989 machines), Move the tapping band on the burden resistor to its maximum position across the droop CT.
2. Run the machine singly at full rated speed, and apply as much inductive load (i.e. motors transformers etc.) as can be obtained.
3. Make a note of the output voltage from the machine terminals.
4. With a switch, short circuit parallel droop transformer, terminals (S1-S2), (or turn the "DROOP" adjustment on the AVR to minimum), and observe the output voltage from the machine.
5. If the voltage RISES slightly, this indicates that the droop circuit is functioning correctly, and polarity is correct.
6. If the voltage has dropped slightly, the droop transformer is reversed, and the connections of its two output leads S1 - S2 should be changed over.
7. After completion of this test, adjust the droop setting to required level.

Setting the droop circuit

The parallel droop CT is connected directly across the AVR terminals S1-S2. Droop adjustment is achieved on the AVR "DROOP" trimmer. Normal setting will be between 25% clockwise, to fully clockwise, depending upon the AVR type, and the level of droop required.

Correct droop adjustment will produce a 3% voltage drop at full load, 0.8 power factor, (as a single running Generator).

Note1: Droop is non-effective at power factor 1, (unity), therefore a power factor of 0.8 is important for correct adjustment.

Note 2: The test load can be reduced pro rata, i.e., at 50% full load 0.8 pf, Voltage droop setting would be 1.5%.

Note 3: Excessive Droop will produce poor voltage regulation from no load to full load at 0.8 pf, and will also produce larger voltage dips during motor starting. The droop should be adjusted to give satisfactory load sharing performance in parallel, without compromising voltage regulation and motor starting performance.

Checking the Droop Current Transformer output

Should problems occur with a), insufficient droop, or b), too much droop, the droop CT output should be checked.

With the droop CT connected to the AVR terminals S1-S2, apply 50% load, (any power factor), to the Generator, and check the output voltage across terminals S1–S2.

At 50% load, the output should be between 0.5 and 2.5 VAC. Voltage reading higher or lower than this indicate

that the CT current rating is incorrect for the Generator current rating.

Note: The droop trimmer setting will not affect this test.

Generators manufactured before 1989

Droop is adjusted on a burden resistor, mounted in the Generator terminal box, and can be checked across the resistor terminals.

If the voltage droop is too great on load, less resistance is required across the droop CT, on the burden resistor. Conversely, a larger droop requires more resistance. A value of between 30 and 50 ohms will give satisfactory performance.

Step by step setting up procedure for parallel operation

The following is intended as a general guide only. If any doubt exists as to the reason for various tests, further reference should be made to the preceding notes. All machines must obviously be correctly wired in accordance with the appropriate connection and wiring diagrams.

- (a) Run No.1 generator on no load at rated speed. Check AC voltage and adjust where necessary.
- (b) Check phase rotation of No. 1 generator.
- (c) Run No. 2 generator and proceed as items a and b, voltages must be within 0.5% of No.1 generator.
- (d) With Nos. 1 and 2 generators running on no load, switch in synchroscope or lights.
- (e) Adjust speed until synchroscope rotates very slowly or lights slowly brighten and dim.
- (f) Check finally that voltages are equal or within 0.5% of each other. Adjust as required.
- (g) Close breaker at synchronism; observe ammeters for circulating current, if in excess of 5%, recheck no load voltage settings and droop circuits for polarity, (reversal of CT terminals S1-S2).
- (h) Increase load until full load appears on each generator when in parallel. Some adjustment to one engine governor may be required to ensure balanced kW meter readings.
- (i) Check the ammeter readings with the kW meters equal. They should be within 5% of each other.
- (j) If the ammeter readings are outside 5%, first check that the meters are all accurate. The machine with the highest current is over-excited, and therefore requires more droop to compensate. Increase the droop setting.
- (k) With full load on each generator reduce the load in 20% increments. At each loading, observe kW meter and ammeter readings down to 20% full load. Any variation of either instrument beyond 5% of each other requires correction.
- (l) Unequal kW sharing implies a faulty prime mover, most likely the governor. Adjust kW sharing on the engine governors, and when equal, check the ammeter readings.
- (m) Unequal ammeter readings at the full load end of the range imply incorrect levels of droop.
- (n) Unequal ammeter readings approaching the no load condition imply incorrect voltage settings.

The most likely procedure that occurs in practice concerns the paralleling of additional machines to already loaded sets. For instance, if a set is supplying a load equal to 75% of its output and further load is anticipated, the engineer may decide to spread this load over two sets. A procedure somewhat on the lines of the following is required: -

The incoming set is started and run at no load frequency. The synchroscope / lights switch is closed, connecting the incoming machine and the busbar via the synchroscope or lights. As the incoming machine is fast, the synchroscope will rotate in the fast direction, or the lights will brighten and dim at the rate dependent of the frequency difference.

The speed of the incoming machine should be reduced by actuating the motorised governor in the slow direction.

When the frequencies are nearly equal, the speed of rotation of the synchroscope or the changes in brilliance of the lights will be slow enough to enable the set contactor to be closed when the voltages are in synchronism. This will be at twelve o'clock position on the synchroscope, or with lights bright or dim dependent on which connection is used.

Note: When synchronising the incoming generator with loaded generators, the loaded generator(s), can have a voltage level up to 4% lower than the in-coming generator. This is normal, and is due to the effect of droop, and AVR regulation. Do not adjust the voltage after the initial no-load setting. This Voltage difference is essential, in order that the incoming Generator starts to take a proportion of the reactive (kVAr), load current on breaker closure.

Load Sharing

In order that the incoming machine may now take its share of the load, the governor control should be held in the speed raise position, until the desired load is indicated by the kW meter and ammeter. Conversely, if too much load is applied holding the governor control in the speed lower position can reduce it. It is most important that the total load be shared in respect of their normal ratings and the meter readings should be compared with the name plate data. In any event, unequal load sharing requires correction to avoid mechanical problems which occur when diesel engines are run light for any considerable time.

It is important to differentiate between unbalanced loading caused simply by the operator failing to spread the load equally over the two sets, and by circulating currents unbalancing the ammeter readings.

For example: consider 2 X 100kVA generators in parallel, with no circulating currents, supplying a load of 150 kVA, at 0.8 p.f.

With the load distributed equally, meter readings would appear as follows:

Machine	VOLTS	AMP	kW	kVA	p.f.
No. 1	415	104	60	75	0.8 lag
No. 2	415	104	60	75	0.8 lag

If the load were distributed unequally, again no circulating currents, the following figures could appear:

Machine	VOLTS	AMP	kW	kVA	p.f.
No. 1	415	139	80	100	0.8 lag
No. 2	415	69	40	50	0.8 lag

If now the same unequally distributed load is being supplied, but circulating currents are present, meter readings something on the lines of the following would be observed.

Machine	VOLTS	AMP	kW	kVA	p.f.
No. 1	415	185	80	133	0.6 lag
No. 2	415	60	40	43	0.93 lead

Machine No. 1 is now supplying 133 kVA at 0.6 pf, considerably in excess of its normal rating. Continued operation under this loading would cause the AVR overload protection circuit to trip, or the main stator and the rotor to fail. Machine No. 2 is operating under-excited, that is, operating with a leading power factor, and at much reduced kVA.

This will not damage No. 2 generator, but it is evident that No. 1 generator is very heavily over-loaded. A leading power factor condition is particularly difficult to detect unless individual power factor meters are fitted. The normal instrumentation of ammeter, voltmeter and kW meter cannot indicate this load condition.

Excitation levels

As a guide to load sharing for similar generators, the D.C. excitation volts should be approximately equal when the generators are correctly sharing reactive and active current. This can be checked across the AVR terminal X+ (F1) and XX- (F2). The Generator with the highest excitation is more lagging, the lowest excitation Generator will more leading power factor.

3. Difficulties

Some paralleling problems, which can occur, are detailed below. Probable causes are also shown.

(a) Oscillating kW meter, ammeter and voltmeter.

Cause: Engine governing. Replace by known serviceable unit. This may also be caused by electronic governors with insufficient speed droop (less than 2%).

(b) Unbalanced ammeter readings. kW meters balanced and stable.

Cause: Circulating current through incorrect voltage settings, droop CT connections reversed or insufficient droop.

(c) Unbalanced ammeter readings on no load or rapidly rising currents as soon as contactor is closed.

Cause: Incorrect voltage settings or droop CT connections reversed.

(d) Unbalanced kW and ammeter readings as load increased or decreased.

Cause: Dissimilar governor speed regulation, or very tight governor control (electronic). If governor is set at less than 2% speed regulation, kW load sharing will be poor.

(e) Unbalanced ammeter readings as load increased. kW meters balanced.

Cause: Droop circuit setting not identical, or one droop kit reversed, or droop CT not in circuit.

Apart from the above problems, certain peculiarities may exist which are in no way detrimental to the operation of the sets. They may, however, confuse the operator into thinking a fault exists.

The most common query results from voltage oscillation during the initial paralleling procedure.

When an additional set is being connected to the busbars with the synchroscope / lights switch in the on position, a point may be reached where the incoming machine voltage starts to fluctuate. This only occurs when the frequency difference is at its greatest. As the frequencies approach each other, no further instability is noticed. This is not, however, a function of the stability circuit within the AVR, but relates to 'pickup' problems associated with the switchboard wiring.

4. Neutral interconnection

It should be noted that paralleling of all system neutrals can under certain circumstances lead to over heating or possible stator burnout's.

This is particularly evident when machines of dissimilar manufacture are paralleled. Differences in generated waveshape may cause large harmonic circulating currents through the neutrals.

The neutrals of dissimilar machines must, therefore, never be connected. On the other hand, neutrals of like machines may be connected.

5. Paralleling with the public supply

The Mains (Utility), Voltage can vary by as much as $\pm 10\%$, (or more in some regions). The droop equipment alone would be unable to maintain control of the resultant reactive currents.

It is therefore recommended that a Power Factor Controller (PFC3) be used, when paralleling with the Mains (Utility).

This enables the Generator to maintain a constant power factor, when the Mains (Utility), Voltage is stepped up or down by the authorities.

The Power Factor Controller (PFC3), can also be supplied with voltage matching facility, which allows the generator voltage to be adjusted automatically to match the public supply, thus reducing any switching transients on closure of the circuit breaker.

Parallel Droop is still required, working in conjunction with the PFC3, to control rapid current surges, and 'soften' the effects of sudden mains voltage stepping.

Droop is also required to control circulating currents when the Generators are required to run in 'Island mode', (as mains failure or emergency supply), during which time the PFC3 must be switched off.

PARALLEL OPERATION FAULT FINDING CHART

SYMPTOM	POSSIBLE CAUSE	TEST AND REMEDIES
CIRCUIT BREAKER WILL NOT CLOSE WHEN ATTEMPTING TO PARALLEL MACHINES.	a) Circuit breaker fitted with 'Check Synchronising' protection, which prevents out of phase paralleling).	a) Ensure that the synchroscope is indicating that machines are IN PHASE, or close to the eleven o'clock position, (when rotating in a clockwise direction). Ensure that the speed difference between the incoming set and the bus bar is small enough to prevent rapid rotation of the synchroscope, (or rapid fluctuations of the lights), before closing circuit breaker.
	b) Phase rotation of one machine is different to the other.	b) Check the phase rotation of each individual Generator. NO ATTEMPT TO PARALLEL must be made until the phase rotations are all identical. Reverse two phases on the Generator, which has a different rotation.
	c) Voltage difference too high between the incoming Generator and the Bus bar.	c) The voltage on the incoming set can be up to 4% higher than the bus bar Voltage. THIS IS NORMAL. Do not adjust original no-load Voltage settings. If difference is greater than 4%, check for excessive droop on the loaded Generator(s).
DIFFICULTY IN MAINTAINING A STABLE IN-PHASE CONDITION, PRIOR TO SYNCHRONISING.	a) Governor drift on one or more of the engines.	a) Let engines stabilise (warm up) before paralleling. If speed is still drifting check governors and engine condition.
	b) Load variation on the bus-bar causing speed/ frequency changes at the time of synchronising.	b) Disconnect any rapidly varying load. Check that there is no likelihood of a motor or automatic load starting when synchronisation is attempted. DO NOT attempt to parallel if the load current is highly unstable.
FREQUENCY (Hz), UNSTABLE WHEN ON LOAD IN PARALLEL.	Engine speed droop too 'tight' or cyclic irregularities (instability), between the engines. (Check kW meters for rapid shifting of kW power between sets).	Increase the engine governor speed droop, to 4% droop, (no load to full load). Check for "sticky" governors on a new engine. Check engines for cyclic problems, (firing, out of balance, etc),
VOLTAGE FLUCTUATES DURING SYNCHRONISATION, (STABLE BEFORE AND AFTER)..	This symptom usually results from line pick-up between the Generators, through the synchronising panel and/or protection circuits, (earth leakage etc), that can form a temporary 'closed loop' link between the Generators during synchronisation.	The fluctuation will decay when the Generators approach synchronism, (almost identical speeds), and will disappear completely when the circuit breaker is closed. The synchronising equipment, earth leakage protection, and/or wiring circuits, in the switchboard can produce pickup problems.
CURRENT RISES RAPIDLY WITHOUT CONTROL AS INCOMING CIRCUIT BREAKER IS CLOSED.	Parallel droop equipment reversed on one of the Generators.	Check the droop CT's for reversal. (See previous text in this section). Reverse lead S1-S2 on the droop CT. Check excitation volts, the Generator with reversal will have highest excitation volts.

SYMPTOM	POSSIBLE CAUSE	TEST AND REMEDIES
CIRCULATING CURRENT ON BOTH GENERATORS AT NO LOAD, (CURRENT IS STABLE).	a) Voltage difference (excitation level) between the Generators.	a) Check Voltages at NO LOAD, (identical frequencies), and ensure all Generators have identical voltages at no load. Do not adjust when load sharing.
	b) Parallel droop equipment reversed on BOTH Generators. (Unlike ONE droop reversal, which is a highly UNSTABLE condition).	b) Check ALL droop CT's for reversal, as suggested in previous test.
	c) Incorrect setting of parallel droop equipment.	c) Check settings of droop trimmers. Check droop CT's are in correct phase. Check CT output to AVR S1-S2 is correct. (See previous text).
KILOWATT METERS SHOWING UNBALANCED READINGS.	Engines not sharing the power (kW) equally.	Adjust the Governors of one engines to equalise the kilowatt sharing.
AMMETERS SHOWING UNBALANCED READINGS AFTER ADJUSTMENT OF THE KILOWATT METERS.	a) Voltage difference (excitation levels) between the machines.	a) Test the machines individually for exact voltage at NO-LOAD.
	b) Parallel droop equipment incorrectly adjusted.	b) Adjust as stated in previous text.
	c) Improved regulation equipment affecting the load sharing. (Pre 1989 machines only.)	c) Short out the improved regulation equipment and test again. Re-adjust if this is causing the problem. Remove improved reg. equipment if AVR's are changed to a later model.
KILOWATT READINGS BECOMING UNBALANCED AS LOAD IS INCREASED OR DECREASED.	Engine governors are incompatible, or new governors 'sticking', giving unequal kW sharing over load variations.	The engine governors must be adjusted to give similar NO-LOAD/FULL LOAD characteristics. Check for 'sticky' governors on new or repainted engines. Electronic governors should be set with a minimum 2% speed droop to ensure satisfactory kilowatt load sharing. If tighter speed regulation is required, an isocronous kW load sharing system should be installed.
AMMETER READINGS BECOME MORE UNBALANCED AS LOAD IS INCREASED.	a) Difference in Parallel droop level settings.	Run Generators SINGLY, and apply load at approximately 25%, 50% & 100%. Take Voltage readings at each level and compare them with the other Generators. Adjust control systems to remove regulation differences. Repeat the above with as much inductive load as possible i.e. motors, transformers etc. Adjust the parallel droop trimmers, to achieve equal inductive load sharing.
	b) Difference in no load to full load voltage regulation of AVR's.	
	These settings are the major contributing factors to the load/voltage characteristics of the machine, and therefore must be set to give equal characteristics to the machines with which it is paralleled.	
VOLTAGE REGULATION POOR AS A SINGLE RUNNING MACHINE.	Excess amount of parallel droop in circuit.	For normal voltage regulation as a single running machine, a shorting switch should be fitted across the parallel droop transformer. (S1-S2). This should be clearly marked 'Single' 'Parallel' operation. (See previous text).
kW METERS UNSTABLE, ENGINES 'ROCKING' ON THEIR MOUNTS.	Electronic engine governor speed 'droop' characteristics set too tight.	At least 2% engine droop is essential for kW (Active current) sharing. If 1% or less speed regulation is required, isocronous governing and kW load sharing system.

