

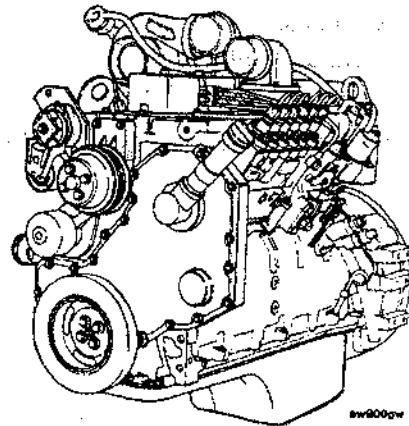

Operation and Maintenance Manual B Series Engines

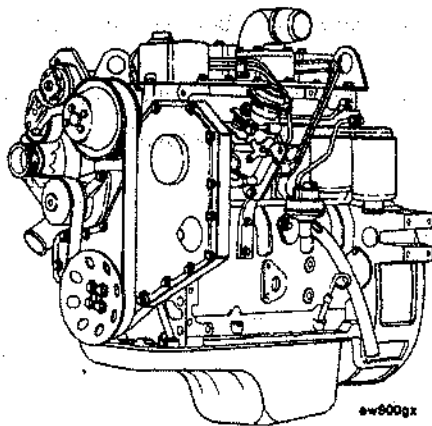

Copyright © 1997
Cummins Engine Company, Inc.
All rights reserved

Foreword

This manual contains information for the correct operation and maintenance of your Cummins engine. It also includes important safety information, engine and systems specifications, troubleshooting guidelines, and listings of Cummins Authorized Repair Locations and component manufacturers.

Keep this manual with the equipment. If the equipment is traded or sold, give the manual to the new owner.

The information, specification, and recommended maintenance guidelines in this manual are based on information in effect at the time of printing. Diesel Engine plant of DongFeng Automobile Co, Ltd.reserves the right to make changes at any time without obligation. If you find differences between your engine and the information in this manual, contact us.

The latest technology and the highest quality components were used to produce this engine. When replacement parts are needed, we recommend using only genuine Cummins exchange parts.

Table of Contents

	Page No.
Introduction.....	i
Engine Identification.....	E
Operating Instructions.....	1
Maintenance Guidelines.....	2
Daily Maintenance Procedures.....	3
Maintenance Procedures at 10,000 kilometers [6,000 Miles] 250 Hours or 3 Months.....	4
Maintenance Procedures at 19,000 kilometers [12,000 Miles] 500 Hours or 6 Months.....	5
Maintenance Procedures at 38,000 kilometers [24,000 Miles] 1000 Hours or 12 Months.....	6
Maintenance Procedures at 77,000 kilometers [48,000 Miles] 2000 Hours or 2 Years.....	7
System Diagrams.....	D
Troubleshooting.....	T

Adjustment, Repair and Replacement.....A

Specifications and Torque Values.....V

Important Reference Numbers

Fill in the part name and number in the blank spaces provided below. This will give you a reference whenever service or maintenance is required.

Engine Model

Engine Serial Number

Engine Specification Number

Fuel Pump Part Number

Filter Part Numbers:

• Air Cleaner Element

• Lubricating Oil

• Fuel

• Fuel Water separator

Belt Part Number

Section i-Introduction

Section Contents

	Page
About the Manual	i-3
Definition of Terms	i-13
General Safety Instructions	i-10
How to Use the Manual	i-4
Illustrations	i-9
Symbols	i-5
To The Owner and Operator	i-2

To The Owner and Operator

Preventative maintenance is the easiest and least expensive type of maintenance. Follow the maintenance schedule recommendations Outlined in Maintenance Guidelines (Section 2).

Keep records of regularly scheduled maintenance.

Use the correct fuel, oil and coolant in your engine as specified in Engine Specifications (Section V).

About the Manual

This manual contains information needed to correctly operate and maintain your engine as recommended by Dongfeng Cummins Engine Co., Ltd. Additional service literature (Shop Manual, Troubleshooting and Repair Manual, etc.) can be ordered by filling out and mailing the Literature order Form located in Service Literature.

This manual does not cover vehicle or equipment maintenance procedures. Consult the vehicle or equipment manufacturer for specific maintenance recommendations.

Numerous illustrations and symbols are used to aid in understanding the meaning of the text. Refer to page i-5 for a complete listing of symbols and their definitions.

Each section is preceded by a "Section Contents" to aid in locating information more quickly.

How to Use the Manual

This manual is organized according to intervals at which maintenance on your engine is to be performed. A table which states the required intervals and the checks to be made is located in Section 2. Locate the interval at which you are performing maintenance then follow the steps given in that section for all the procedures to be performed. In addition, all the procedures done under previous maintenance intervals must be performed.

Keep a record of all the checks and inspections made. A record form for recording date, mileage / kilometer or hours, and which maintenance checks were performed is located in Section 2.

Refer to Section T for a guide to troubleshooting your engine. Follow the directions given on page T — 2 to locate and correct engine problems.

Refer to Section V for specifications recommended for your engine. Specifications and torque values for each engine system are given in that section.

Symbols

The following symbols have been used in this manual to help communicate the intent of the instructions. When one of the symbols appears the meaning defined below:



WARNING-Serious personal injury or extensive property damage can result if the warning instructions are not followed.



CAUTION-Minor personal injury can result or a part, an assembly, or the engine can be damaged if the caution instructions are not followed.



Indicates a **REMOVAL** or **DISASSEMBLY** step.



Indicates an **INSTALLATION** or **ASSEMBLY** step.



INSPECTION is required.



CLEAN the part or assembly.



PERFORM a mechanical or time **MEASUREMENT**.



LUBRICATE the part or assembly.



Indicates that a **WRENCH** or **TOOL SIZE** will be given.



TIGHTEN to a specific torque.



PERFORM an electrical **MEASUREMENT**.



Refer to another location in this manual or another publication for additional information.



The component weighs 23 kg [50 lb] or more. To avoid personal injury, use a hoist or get assistance to lift the component.

Simbolo

Los simbolos siguientes son usados en este manual para clarificar el proceso de las instrucciones. Cuando aparece uno de estos simbolos, su significado se especifica en la parte inferior.



ADVERTENCIA-Serios danos personales o dano a la propiedad puede resultar si las instrucciones de Advertencia no se consideran.



PRECAUCION-Danos menores pueden resultar, o de piezas del conjunto o el motor puede averiarse si las instrucciones de Precaucion no se siguen.



Indica un paso de **REMOCLON** o **DESMONTAJE**.



Indica un paso de **INSTALACION** o **MON-TAJE**.



se requiere **INSPECCION**.



LIMPIESE la pieaze o el montaje.



EJECUTESE una **MEDICION** mecanica o del tiempo.



LUBRIQUESE la pieza o el montaje.



Indica que se dara una **LLAVE DE TUER-CAS** o el **TAMANO DE HERRAMIENTA**.



APRIETESE hasta un par torsor especifico.



EJECUTESE una **MESICION** electrica.



Para informacion adicional referase a otro emplazamiento de este manual o a otra publicacion anterior.



El componente pesq 23 kg [50 lb] o mas. Para evitar dano corporal empleen una cabria u obtengan ayuda para elevar el com ponente.

Symbole

In diesem Handbuch werden die folgenden Symbole verwendet, die wesentliche Funktionen hervorheben. Die Symbole haben folgende Bedeutung:



WARNUNG-Wird die Warnung nicht beachtet, dann besteht erhöhte Unfall-und Beschadigungsgefahr.



VORSICHT-Werden die Vorsichtsmassnahmen nicht beachtet, dann besteht Unfall-und Beschadigungsgefahr.



AUSBAU bzw. **ZERLEGEN**.



EINBAU bzw. **ZUSAMMENBAU**.



INSPEKTION erforderlich.



Teil oder Baugruppe **REINIGEN**.



DIMENSION-oder ZEITMESSUNG.



Teil oder Baugruppe **OLEN**.



WERKZEUGGROSSE wird angegeben.

ANZUG auf vorgeschriebenes Drehmoment erforderlich.



Elektrische **MESSUNG DURCHFÜHREN**.



Weitere Informationen an anderer Stelle bzw. in anderen Handbuchern.



Das teil wiegt 23 kg [50 lb] oder mehr. Zur Vermeidung von Koerperverletzung winde benutzen oder hilfe beim heben des teils in anspruch nehmen.



Symboles

Les symboles suivants sont utilisés dans ce manuel pour aider à communiquer le but des instructions. Quand l'un de ces symboles apparaît, il évoque le sens défini ci-dessous:



AVERTISSEMENT-De graves lésions corporelles ou des dommages matériels considérables peuvent survenir si les instructions "Avertissement" ne sont pas suivies.



ATTENTION-De petites lésions corporelles peuvent survenir, ou bien une pièce, un ensemble ou le moteur peuvent être endommagés si les instructions données sous les rubriques "Attention" ne sont pas suivies.



Indique une opération de **DEPOSE**.



Indique une opération de **MONTAGE**.



L'INSPECTION est nécessaire.



NETTOYER la pièce ou l'ensemble.



EFFECTUER une **MESURE** mécanique ou de temps.



GRAISSER la pièce ou l'ensemble.



Indique qu'une **DIMENSION DE CLE** ou **D'OUTIL** sera donnée.



SERRER à un couple spécifique.



EFFECTUER une **MESURE** électrique.



Se reporter à un autre endroit dans ce manuel ou à une autre publication pour obtenir des informations plus complètes.



Le composant pèse 23 kg [50 lb] ou davantage. Pour éviter toute blessure, employer un appareil de levage ou demander de l'aide pour le soulever.

Section i-Introduction
B Series

Illustrations

Use the illustrations in this manual as a guide to perform the action or the repair described. Many illustrations are generic and will not look exactly like the engine or the parts used in your application. In order to provide clarity to illustrations, some illustrations show parts removed that are not related to the specific parts given in the text.



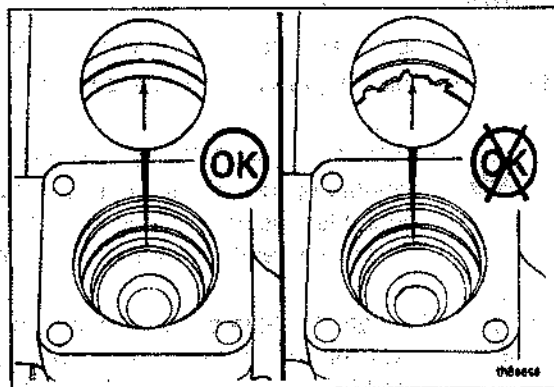

Most of the illustrations contain symbols to indicate an action required or to indicate an **acceptable (OK)** or **unacceptable (not OK)** condition.









General Safety Instructions

Read and understand all of the safety precautions and warnings before performing any repair. This list contains the general safety precautions that must be followed to provide personal safety. Special safety precautions are included in the procedures when they apply.

NOTE: It is not possible for Cummins Engine Company, Inc. to anticipate every possible circumstance that can involve a potential hazard.

-  **Warning: Disconnect the battery and discharge any capacitors before beginning any repair work. Disconnect the air starter, if equipped, to prevent accidental engine starting. Put a "Do Not Operate" tag in the operator's compartment or on the controls.**
-  **Warning: Use ONLY the correct engine barring techniques for manually rotating the engine. Do not attempt to rotate the engine by pulling or prying on the fan. This practice can cause serious personal injury, property damage, or damage to the fan blade (s), causing premature fan failure.**
-  **Warning: If an engine has been operating and the coolant is hot, allow the engine to cool before you slowly loosen the filler cap and relieve the pressure from the cooling system.**
-  **Warning: Do not work on anything that is supported ONLY by lift jacks or a hoist. Always use blocks or correct stands to support the product before performing any service work.**

-  **Warning:** To avoid burns, be alert for hot component parts just after the engine has been shut off and for hot fluids in lines, tubes, and compartments.
-  **Warning:** Relieve all pressure in the air, the oil, and the cooling systems before any lines, fittings, or related items are removed or disconnected. Be alert for possible pressure when disconnecting any device from a system that utilizes pressure. Do not check for pressure leaks with your hand. High pressure oil or fuel can cause personal injury.
-  **Warning:** To prevent suffocation and frostbite, wear protective clothing and **ONLY** disconnect liquid refrigerant (freon) lines in a well ventilated area. Use a freon capture system to prevent leakage to the atmosphere. If in doubt, contact your state and local environmental authorities or the Environmental Protection Agency (EPA) for guidance as to proper handling of freon.
-  **Warning:** Corrosion inhibitor contains alkali. Do not get the substance in your eyes. Avoid prolonged or repeated contact with skin. Do not swallow internally. In case of contact, immediately wash skin with soap and water. In case of contact, immediately flood eyes with large amounts of water for a minimum of 15 minutes. **IMMEDIATELY CALL A PHYSICIAN. KEEP OUT OF REACH OF CHILDREN.**
-  **Warning:** Always use proper tools that are in good condition. Make sure you understand how to use them before performing any service work.
-  **Warning:** Always use the same fastener part number (or equivalent) when replacing fasteners. Do not use a fastener of lesser quality if replacements are necessary.
-  **Warning:** Never use gasoline or other flammable materials to clean parts. Always use approved cleaning Solvents.



Warning: Avoid prolonged and repeated skin contact with used engine oils. Such prolonged and repeated contact may cause serious skin disorders or other serious bodily injury.

- **Avoid excessive contact. Wash thoroughly after contact.**
- **Keep out of reach of children.**

PROTECT THE ENVIRONMENT: Handling and disposal of used engine oils may be subject to federal, state and local law and regulation. Use authorized waste disposal facilities, including civic amenity sites and garages providing authorized facilities for receipt of used oil. If in doubt, contact your state and local environmental authorities or the Environmental Protection Agency for guidance as to proper handling and disposal of used engine oil.

Dispose of antifreeze properly. Handling and disposal of antifreeze can be subject to Federal, State and Local regulation. If in doubt, contact your state and local authorities or the Environmental Protection Agency (EPA) for guidance as to proper handling and disposal of used antifreeze.

Definition of Terms

AFC	Air Fuel Control	H₂O	Water
API	American Petroleum Institute	in-lb	Inch Pound
ASA	Air Signal Attenuator	kg	Kilograms
ASTM	American Society of Testing and Materials	km	Kilometers
C	Celsius	km/l	Kilometers per Liter
CAC	Charge Air Cooled	kPa	Kilopascal
CARB	California Air Resources Board	KSB	Cold Start Advance
C. I. D.	Cubic Inch Displacement	l	Liter
Cm	Centimeter	LDA	Air-Fuel Control
CPL	Control Parts List	m	Meter
cSt	Centistokes	mm	Millimeter
DCA	Diesel Coolant Additive	MPa	Megapascal
E. C. S.	Emission Control System	MPH	Miles Per Hour
EPA	Environmental Protection Agency	MPQ	Miles Per Quart
F	Fahrenheit	N · m	Newton-meter
ft-lb	Foot Pound	OEM	Original Equipment Manufacturer
GVW	Gross Vehicle Weight	ppm	Parts Per Million
Hg	Mercury	psi	Pounds Per Square Inch
HP	Horsepower	RPM	Revolutions Per Minute
		S. A. E	Society of Automotive Engineers

Section E-Engine and Component Identification

Section Contents

	Page
Industrial Engine Nomenclature	E-3
External Engine Components	E-14
General Specifications (Non-Automotive Engines)	E-6
Batteries(Specific Gravity)	E-9

Section E-Engine and Component Identification B Series

Industrial Engine Nomenclature

The model name for Industrial engines provides the following engine data:

4 B T A 3.9

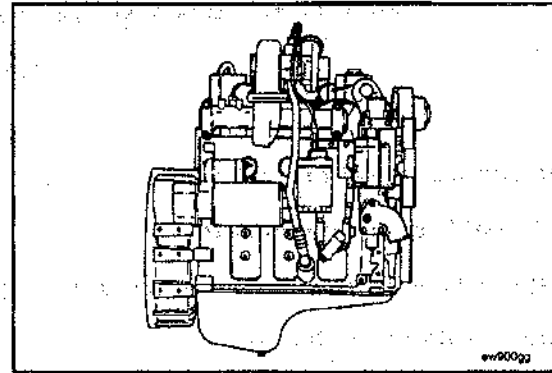
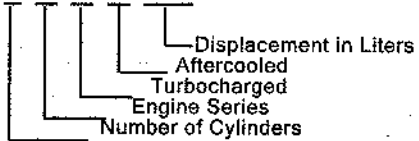

General Specifications (Non-Automotive Engines)

GENERAL ENGINE DATA	4B3.9	4BT3.9	4BTA3.9	6B5.9	6BT5.9	6BTA5.9
Bore-mm [in.].....			102 [4.02]			
Stroke-mm [in.].....			120 [4.72]			
Displacement-liter [in. ³]....		3.9 [239]			5.9 [359]	
Engine Weight (Dry) Less Flywheel and Electric/kg [lbs.].....	308 [680]	320 [705]	329 [725]	388 [855]	399 [880]	411 [905]
Firing Order.....		1.3.4.2			1.5.3.6.2.4	
Valve Clearances						
-Intake-mm [in.].....			25 [0.010]			
-Exhaust-mm [in.].....			51 [0.020]			
Compression Ratio.....	18.5 : 1	17.5 : 1	16.5 : 1	18.5 : 1	17.5 : 1	16.5 : 1
Rotation, viewed from the Front of the Engine.....						Clockwise
Aspiration	x			x		
-naturally Aspirated.....		x	x		x	x
-Turbocharged.....			x			x
-Aftercooled.....						
-Charge Air Cooled.....						

NOTE: See additional pages for Automotive Specifications.

LUBRICATION SYSTEM kPa [psi]	4B3.9	4BT3.9	4BTA3.9*	6B5.9	6BT5.9	6BTA5.9*
Minimum Allowable Oil Pressure@Idle	69 [10]	69 [10]	69 [10]	69 [10]	69 [10]	69 [10]
Minimum Allowable Oil Pressure@Rated	207 [30]	207 [30]	207 [30]	207 [30]	207 [30]	207 [30]
Regulated Pressure	449 [65]	449 [65]	449 [65]	449 [65]	449 [65]	449 [65]
Differential Pressure to Open Filter Bypass	138 [20]	138 [20]	138 [20]	138 [20]	138 [20]	138 [20]
Oil Capacity L [QT]						
Standard Pan Only	9.5 [10]	9.5 [10]	9.5 [10]	14.2 [15]	14.2 [15]	14.2 [15]
Total System (Pan, Filter, Lines)	10.9 [11.5]	11 [11.6]	11 [11.6]	16.3 [17.2]	16.4 [17.3]	16.4 [17.3]
No.QTS From "L" to "H" on Dipstick	[1]	[1]	[1]	[2]	[2]	[2]
COOLING SYSTEM L [QT]						
Engine Coolant Capacity	7.0 [7.4]	7.0 [7.4]	7.9 [8.4]	9.0 [9.5]	9.0 [9.5]	9.9 [10.5]
Thermostat Modulating Range °C[°F]	83-95 [181-230]	83-95 [181-203]	83-95 [181-203]	83-95 [181-203]	83-95 [181-203]	83-95 [181-203]
Pressure Cap kPa [psi]						
104 °C [220 °F]	103 [15]	103 [15]	103 [15]	103 [15]	103 [15]	103 [15]
99 °C [210 °F]	48 [7]	48 [7]	48 [7]	48 [7]	48 [7]	48 [7]

*Jacket-water aftercooled

Section E-Engine and Component Identification
B Series

General Specifications (Non-Automotive Engines)
Page E-9

INTAKE AIR, EXHAUST AND FUEL SYSTEM	4B3.9	4BT3.9	4BTA3.9	6B5.9	6BT5.9	6BTA5.9
Maximum Allowable Intake Restriction at Rated Speed and Load with Dirty Speed Filter El- ement-mm H ₂ O [in. H ₂ O].....	508 [20]	635 [25]	635 [25]	508 [20]	635 [25]	635 [25]
Maximum Allowable Exhaust Restriction at Rated Speed and Load-mm Hg [in. Hg].....	76.2mm [3 in.]					
Maximum Fuel Pressure Drop Across Filters kPa [psi].....	34mm [5]					
Maximum Allowable Return Line Restriction-mm Hg [in. Hg]....	518mm [20.4 in]					
Maximum Inlet Restriction to fuel transfer pump- mm Hg [in. Hg].....	100 [4]					

General Specifications (Non-Automotive Engines)
Page E-10

Section E-Engine and Component Identification
B Series

ELECTRICAL SYSTEM	4B3.9	4BT3.9	4BTA3.9	6B5.9	6BT5.9	6BTA5.9
Minimum Recommended Battery Capacity- With Light Accessories*						
-12 V Starter.....	625CCA	625CCA	625CCA	800CCA	800CCA	800CCA
-24 V Starter.....	312CCA	400CCA	400CCA	400CCA	400CCA	400CCA
With Heavy Accessories**						
-12 V Starter.....	800CCA	800CCA	800CCA	950CCA	950CCA	950CCA
-24 V Starter.....	400CCA	400CCA	400CCA	475CCA	475CCA	475CCA
Maximum Allowable Resistance of Starting Circuit						
-With 12 V Starter-Ohms..... 0012					
-With 24 V Starter-Ohms..... 0020					

*Typical light accessories include alternator, small steering pump, and disengaged clutch.

**Typical heavy accessories include hydraulic pump and torque converter.

Batteries (Specific Gravity)

Specific Gravity at 27°C [80°F]	State of Charge
1.260-1.280	100%
1.230-1.250	75%
1.200-1.220	50%
1.170-1.190	25%
1.110-1.130	Discharged

External Engine Components

The illustrations which follow show the locations of the major external engine components, the filters, and other service and maintenance points. Some external components will be at different locations for different engine models.

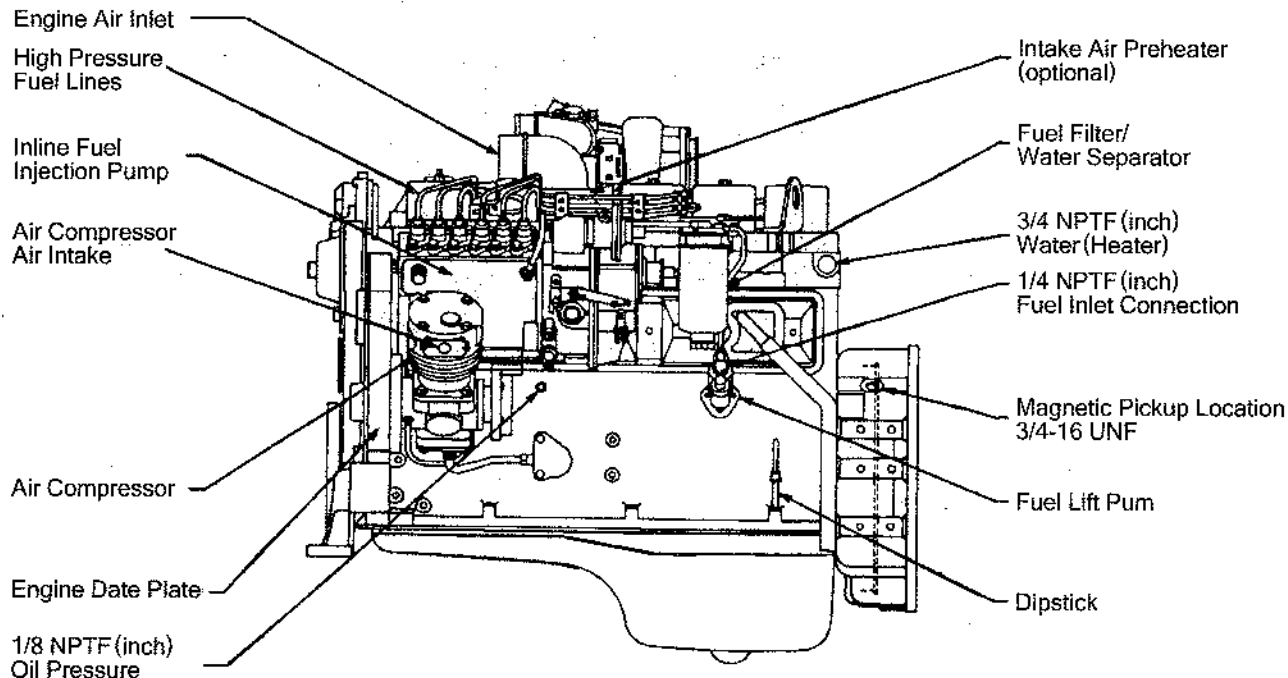

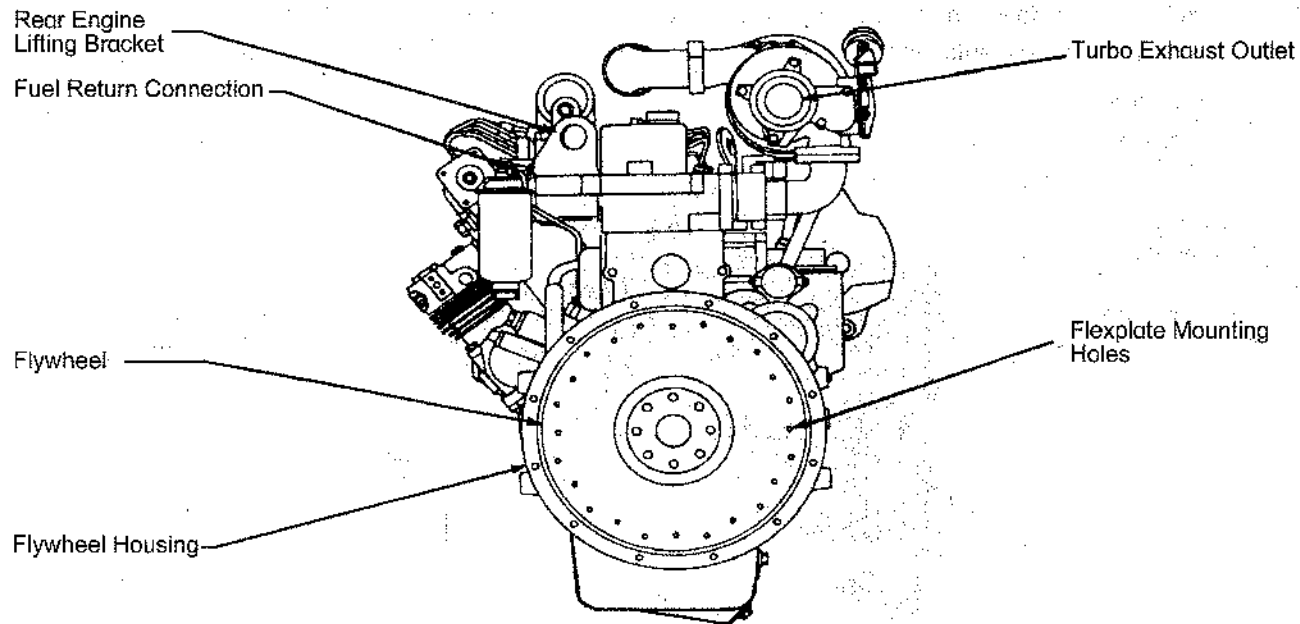

Rear View

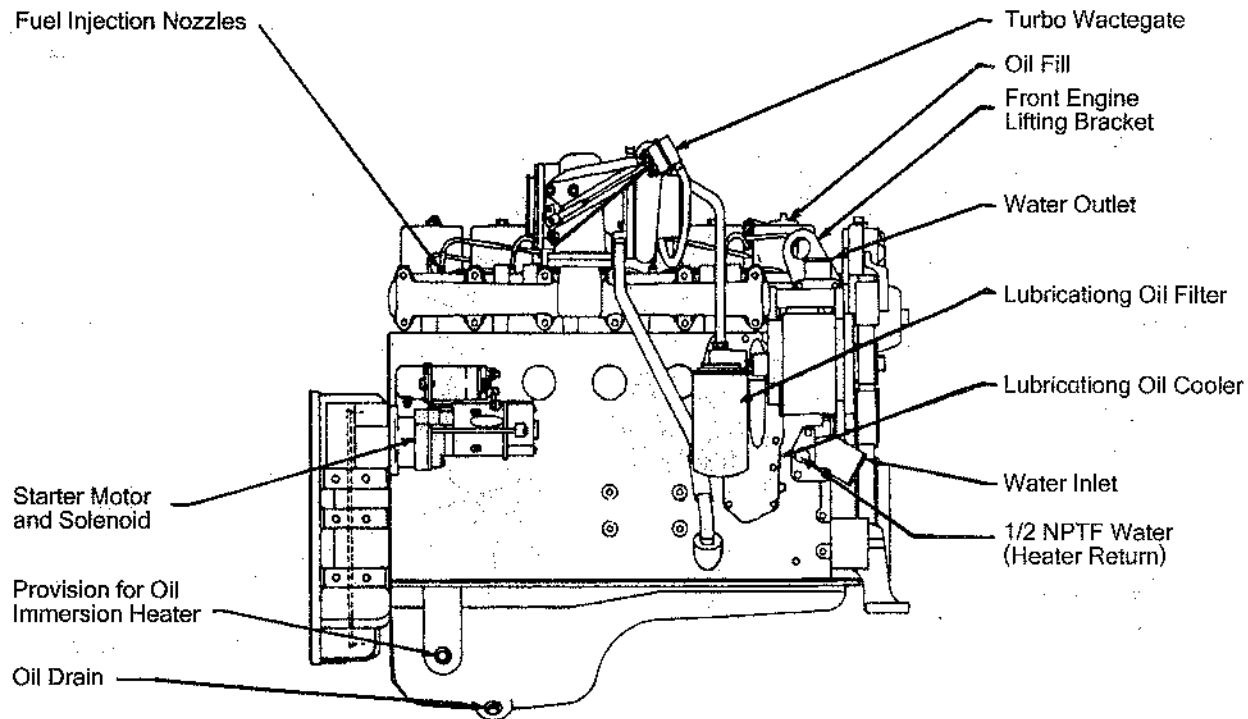

Turbocharger Side View

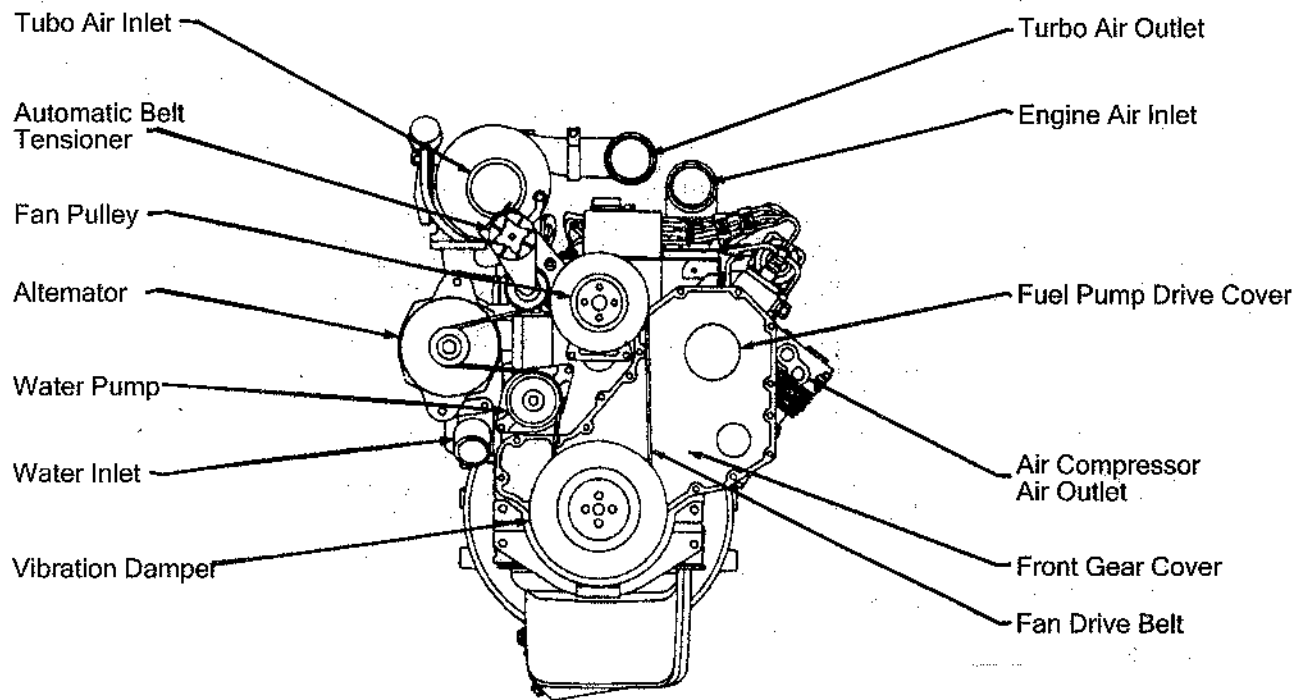

Front View

Section 1-Operating Instructions

Section Contents

	Page
Cold Weather Starting	1-5
Using Starting Fluid With Mechanical or Electrical Metering Equipment.....	1-5
Using Starting Fluid Without Metering Equipment.....	1-5
Cold Weather Operation	1-4
Shutters.....	
Winterfronts.....	
Engine Operating Range	1-8
Enging Shut-down	1-8
General Information	1-2
Starting Procedure	1-2
Operating the Engine	1-7
Starting Procedure-After Extended Shutdown or Oil Change	1-6

General Information

Correct care of your engine will result in longer life, better performance, and more economical operation.

- Follow the daily maintenance checks listed in Maintenance Guidelines, Section 2.
- Check the oil pressure indicators, temperature indicators, warning lights, and other gauges daily to make sure they are operational.



Warnign: DO NOT OPERATE A DIESEL ENGINE WHERE THERE ARE OR CAN BE COMBUSTIBLE VAPORS. These vapors can be drawn through the air intake system and cause engine acceleration and over-speeding, which can result in a fire, an explosion and/or extensive property damage. Numerous safety devices are available, such as air intake shut-off devices, to minimize the risk of over-speeding where an engine, due to its application, might operate in a combustible environment, such as due to a fuel spill or gas leak. Remember, Cummins has no way of knowing the use you have for your engine. **THE EQUIPMENT OWNER AND OPERATOR ARE RESPONSIBLE FOR SAFE OPERATION IN A HOSTILE ENVIRONMENT CONSULT YOUR CUMMINS AUTHORIZED REPAIR LOCATION FOR FURTHER INFORMATION.**

Starting Procedure

Automotive- (Bosch VE and P-Pumps with RQV-K Governor) above 16 °C [60 °F]

Foot off throttle. The VE pump has an internal starting circuit to provide starting fuel delivery. The inline pump delivers sufficient fuel to start engine with throttle at idle.

Automotive- (Bosch VE and P-Pumps with RQV-K Governor) below 16 °C [60 °F]

Foot at full throttle while cranking. The VE pump has an internal circuit to provide starting fuel delivery, and open throttle helps keep the engine operating, once started. The inline pump requires open throttle to position and hold the rack in the maximum fuel position.

Industrial/Marine- (Bosch VE, Lucas DPA, Stanadyne DP4, Nippondenso EP-9) above 0 °C [32 °F]

Foot off throttle. The VE pump has an internal starting circuit to provide starting fuel delivery. The DPA pump has a metering valve which will remain in start position if cranking speed does not approach idle speed. The EP-9 pump has a "Start Spring" which automatically moves the rack to the start fuel position.

Industrial/Marine

• **(Bosch VE)below 0 °C [32 °F]**

Foot at full throttle while cranking. The VE pump has an internal circuit to provide starting fuel delivery, and open throttle helps keep the engine operating, once started.

• **(Lucas DPA, Stanadyne DP4 and Nippondenso EP-9)below 0 °C [32 °F]**

Foot off throttle. The DPA pump has a metering valve which will remain in start position if cranking speed does not approach idle speed. The EP-9 has a "start Spring" which automatically moves the rack to the start fuel position.

Starting Procedure Matrix

	Idle Throttle	Full Throttle
Automotive		
All pumps-above 16°C [60°F].....	x	
All pumps-below 16°C [60°F].....		x
Industrial/Marine		
All pumps-above 0°C [32°F].....	x	
All except Bosch VE-below 0°C [32°F].....	x	
Bosch VE-below 0°C [32°F].....		x

- Disengage the driven unit, or if equipped, put the transmission in neutral.
- Position the fuel shut-off, electrical switch or mechanism control to the RUN position.



Caution: To prevent damage to the starter, do not engage the starting motor more than 30 seconds. Wait 2 minutes between each attempt to start (electrical starting motors only).

- If the engine does not start after three attempts, check the fuel supply system. Absence of blue or white exhaust smoke during cranking indicates no fuel is being delivered.

- Move the throttle position to idle as the engine starts.
- Engine oil pressure must be indicated on the gauge within 15 seconds after starting.
- When starting a cold engine, increase the engine speed (RPM) slowly to make sure adequate lubrication is available to the bearings.

⚠ Caution: Do not idle the engine for excessively long periods. Long periods of idling (more than 10 minutes) can damage an engine because combustion chamber temperatures drop so low the fuel will not burn completely. This will cause carbon to clog the injector spray holes and piston rings, and can cause the valves to stick. If the engine coolant temperature becomes too low (60 °C [140 °F]), raw fuel will wash the lubricating oil off the cylinder walls and dilute the crankcase oil; therefore, all moving parts of the engine will not receive the correct amount of lubrication.

- Idle the engine 3 to 5 minutes before operating with a load.

⚠ Caution: When using jumper cables to start the engine, make sure to connect the cables in parallel: positive (+) to positive (+) and negative (-) to negative (-). When using an external electrical source to start the engine, turn the disconnect switch to the "OFF" position. Remove the key before attaching the jumper cables to prevent unintentional starter engagement.

Cold Weather Operation

Starting Aid Requirements

Use the following chart as a reference for required cold weather starting aids:

Operation in ambient temperatures below 0°C [32°F] can require special consideration be given to engine starting. At temperatures below 0°C [32°F], operate the engine at moderate speeds for 5 minutes before full loads are applied.

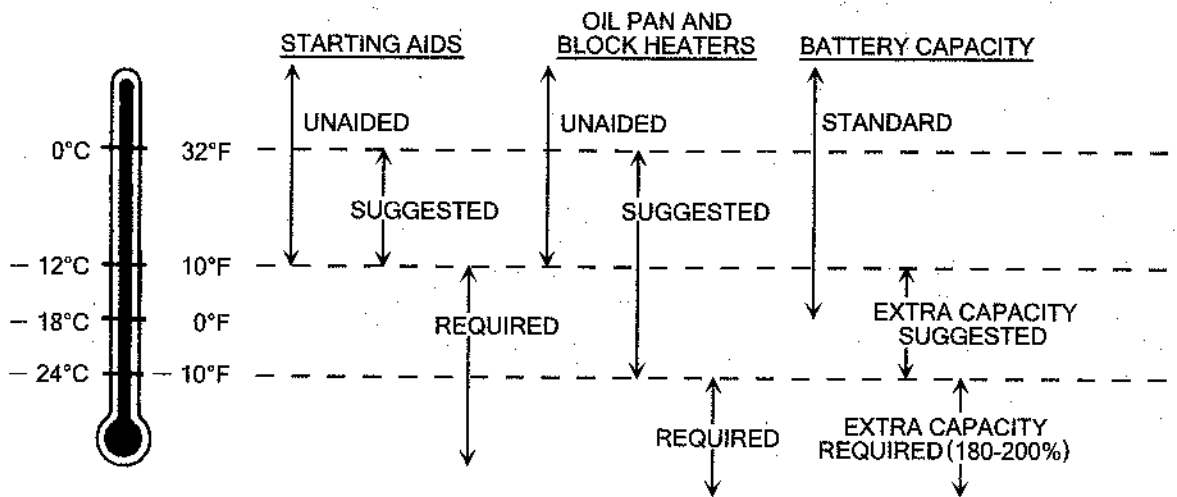

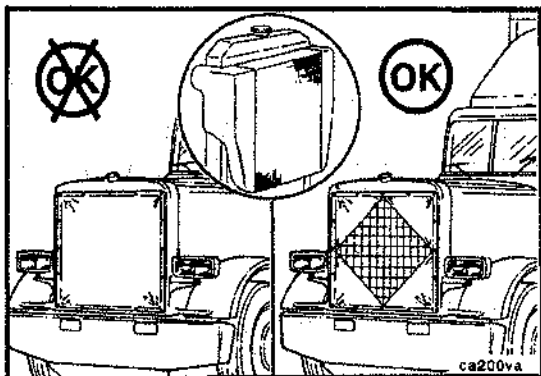

Winterfronts

Winterfronts can be used on a vehicle equipped with charge air cooling (CAC), but must be designed to partially cover the frontal area of the cooling system. A minimum of 120 square inches (11 in × 11 in) of frontal area must be left open to air flow for the CAC to function correctly.

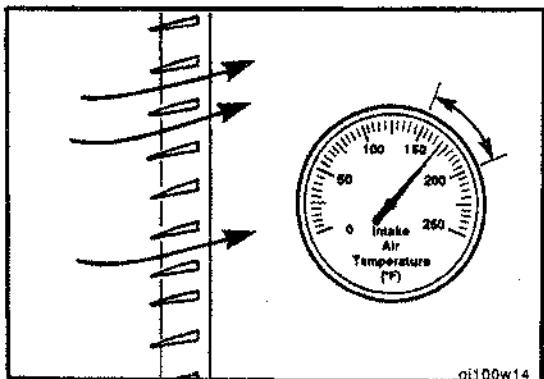

Shutters





Installations of CAC engines with shutters also requires an intake manifold air temperature switch to open the shutters to prevent excessive intake manifold temperatures. This prevents engine damage due to high intake manifold temperatures as a result of blocked air flow across the CAC.

Cold Weather Starting

Using Starting Fluid With Mechanical or Electrical Metering Equipment

- Set the throttle at half speed.
- Disengage the driven unit, or if equipped, put the transmission in neutral.
- Activate the switch to open the fuel pump shut-off valve.
- While cranking the engine, inject metered amounts of starting fluid.
- Engine oil pressure must be indicated on the gauge within 30 seconds after starting.

Using Starting Fluid Without Metering Equipment

-  **Warnign: Never use starting fluid near an open flame, or with a preheater or flame thrower equipment. This combination can cause an explosion.**
-  **Warning: Do not breathe starting fluid fumes. Starting fluid fumes can be harmful to your health.**
-  **Caution: Do not use excessive amounts of starting fluid when starting an engine. The use of too much starting fluid will cause engine damage.**
- Spray starting fluid into the air cleaner intake while another person cranks the engine.
-  **Warning: Do not use volatile cold starting aids in underground mine or tunnel operations due to the potential of an explosion. Check with the local U. S. Bureau of Mines Inspector for instructions.**

Starting Procedure-After Extended Shutdown or Oil Change

Complete the following steps after each oil change, or after the engine has been shut off for more than 7 days to make sure the engine receives the correct oil flow through the lubricating oil system:

- Disconnect the electrical wire from the fuel pump solenoid valve.
- Rotate the crankshaft, using the starting motor, until oil pressure appears on the gauge, or the warning light goes out.
- Connect the electrical wire to the fuel pump solenoid valve.
- Start the engine; refer to Normal Starting Procedures in this section.
- Refer to Fuel System-Bleeding, Section 5, for instructions to vent the fuel system.

Operating the Engine

- Do not operate engine at full throttle below peak torque engine speed (1100 to 1600 RPM, dependent on engine rating) for extended periods (more than 1 minute) of time.
- Allow the engine to idle 3 to 5 minutes before shutting it off after a full load operation.
- Monitor the oil pressure and coolant temperature gauges frequently. Refer to Lubricating Oil System or Cooling System, Section v, for recommended operating pressures and temperatures. Shut off the engine if any pressure or temperature does not meet the specifications.





Caution: Continuous operation with low coolant temperature (below 60°C [140°F]) or high coolant temperature (above 100°C [212°F]) can damage the engine.

- If an overheating condition starts to occur, reduce the power output of the engine by releasing the throttle pressure or shifting the transmission to a lower gear, or both, until the temperature returns to normal operating range. If engine temperature does not return to normal, shut off the engine and refer to Troubleshooting, Section T, or contact a Cummins Authorized Repair Location.
- Most failures give an early warning. Look and listen for changes in performance, sound, or engine appearance that can indicate service or engine repair is needed. Some changes to look for are as follows:
 - Engine misfires
 - Excessive smoke
 - Vibration
 - Loss of power
 - Unusual engine noises
 - An increase in oil consumption
 - Fuel, oil, or coolant leaks
 - An increase in fuel consumption
 - Sudden changes in engine operating temperature or oil pressure

Engine Operating Range

 **Caution:** Cummins engines are designed to operate successfully at full throttle under transient conditions down to peak torque engine speed (RPM). This is consistent with recommended driving practices for good fuel economy. Excessive full throttle operation below peak torque RPM (peak torque RPM varies from 1,100 RPM to 1,600 RPM, depending upon rated engine speed) will shorten engine life to overhaul, can cause serious engine damage, and is considered engine abuse.

 **Caution:** Operation of the engine below peak torque RPM can occur during gear shifting due to the difference of ratios between transmission gears, but engine operation must not be sustained more than 1 minute at full throttle below peak torque RPM.

 **Caution:** Operating the engine beyond high idle speed can cause severe engine damage. When descending a steep grade, use a combination of transmission gears and engine or service brakes to control the vehicle and engine speed.

Engine Shut-down

- Allow the engine to idle 3 to 5 minutes after a full load operation before shutting it off. This allows the engine to cool gradually and uniformly.
- Turn the ignition key switch to the OFF position.

Section 2-Maintenance Guidelines

Section Contents

	Page
General Information	2-2
Maintenance Record Form	2-8
Maintenance Schedule	2-4
Page References for Maintenance Instructions.....	2-5
Tool Requirements	2-3

General Information

Cummins Engine Company, Inc. recommends that the engine be maintained according to the Maintenance Schedule in this section.

If the engine is operating in ambient temperatures consistently below -18°C [0°F] or above 38°C [100°F], perform maintenance at shorter intervals. Shorter maintenance intervals are also required if the engine is operated in a dusty environment or if frequent stops are made. See your Cummins Authorized Repair Location for recommended intervals.

Use the chart provided at the end of this section as a convenient way to keep a record of maintenance performed.

Tool Requirements

In the text, a symbol followed by the wrench size or tool description is used to identify the tooling required to perform each step. A list of wrench sizes and descriptions indicate more than one tool is needed.

Sockets	Wrenches	Other Tools
19mm	19mm	Fuel line nuts
17mm	17mm	Filter Wrenches (75-80mm and 90-95mm)
15mm	15mm	Ratchet (1/2 inch drive)
	14mm	Torque Wrench
	13mm	Flat Blade Screwdriver
	10mm	5/16 Allen Wrench
		Feeler Gauges (0.25 mm and 0.51 mm)
		Engine Barring Gear Part NO. 3377371.

Maintenance Schedule

Daily or Refueling	Every 10,000 Km [6,000 Mi], 250 Hours or 3 Months	Every 19,000 Km [12,000 Mi], 500 Hours or 6 Months	Every 38,000 Km [24,000 Mi] 1000 Hours or 12 Months	Every 77,000 Km [48,000 Mi], 2000 Hours or 2 Years
Check	----- Change/Replace -----			
<ul style="list-style-type: none"> • Oil Level • Coolant Level • Fan-Inspection • Drive Belt-Inspection • Fuel Water Trap 	<ul style="list-style-type: none"> • Lube Oil^① • Lube Filter 	<ul style="list-style-type: none"> • Lube Oil • Lube Filter • Fuel Filter^② 	<ul style="list-style-type: none"> • Lube Oil • Lube Filter • Fuel Filter 	<ul style="list-style-type: none"> • Lube Oil • Lube Filter • Fuel Filter • Antifreeze^③
	----- Adjust -----			
			<ul style="list-style-type: none"> • Valve Lash^④ Clearance 	
	----- Check/Inspect -----			
	<ul style="list-style-type: none"> • Air Cleaner • Intake System • Charge Air Cooler 	<ul style="list-style-type: none"> • Air Cleaner • Intake System • Antifreeze^⑤ • Charge Air Cooler 	<ul style="list-style-type: none"> • Air Cleaner • Intake System • Charge Air Cooler • Antifreeze • Fan Hub • Belt Tensioner Bearing • Belt Tension 	<ul style="list-style-type: none"> • Air Cleaner • Charge Air Cooler^⑥ • Intake System • Fan Hub • Belt Tensioner Bearing • Belt Tension • Damper

^① Refer to the Oil Change Interval chart given in Section 4 to find the specific oil change interval for your application.

^② Initial valve lash clearance adjustment, subsequent adjustments to be performed at 77,000 Km [48,000 mile] or every 4th oil change for automotive engines and, 2000 hour, 2 year intervals.

^③ Must use a heavy duty year around antifreeze that meets the chemical composition of GM6038M. The change interval is 2 years or 320,000 Km [200,000 Mi], whichever occurs first. Antifreeze is essential for freeze, overheat and corrosion protection.

^④ Service interval is 2 years or 320,000 Km [200,000 Mi], whichever occurs first.

^⑤ Service interval is every other oil change or 19,000 Km [12,000 miles], 500 hours or 6 months.

Page References for Maintenance Instructions

For your convenience, listed below are the page numbers which contain specific instructions for performing the maintenance checks listed in the maintenance schedule.

Daily or Refueling

• Belts-inspect.....	3-5
• Engine oil level-check.....	3-3
• Engine coolant level-check.....	3-4
• Fan-inspect.....	3-6
• Fuel-water separator-drain.....	3-3

Every 10,000 Kilometers [6,000 Miles], 250 Hours or 3 Months

• Lubricating oil-change.....	4-5
• Lubricating oil filters-change.....	4-5
• Air intake system check.....	4-11
• Air cleaner restriction-check.....	4-12
• Charge Air Cooler.....	4-11

Every 19,000 Kilometers [12,000 Miles], 500 Hours or 6 Months

• Lubricating oil-change.....	4-5
• Lubricating oil filter-change.....	4-5
• Fuel filter-change.....	5-3
• Intake air system-check.....	4-11
• Charge Air Cooler.....	4-11
• Coolant and Antifreeze-check.....	5-9

Every 38,000 Kilometers [24,000 Miles], 1000 Hours or 12 Months

• Lubricating oil-change.....	4-5
• Lubricating oil filter-change.....	4-5
• Fuel filter-change.....	5-3
• Intake air system-check.....	4-11
• Charge Air Cooler.....	4-11
• Valve lash clearance-adjust (first time only, thereafter every 64,000 KM).....	6-3
• Fan hub-check.....	6-11
• Belt tensioner bearing-check.....	6-11
• Belt tension-check.....	6-9
• Coolant and antifreeze-check	

Every 77,000 Kilometers [48,000 Miles], 2,000 Hours or 2 Years

•Lubricating oil - change.....	4-5
•Lubricating oil filter - change.....	4-5
•Fuel filter - change.....	5-3
•Intake air system - check.....	5-3
•Valve lash clearance - adjust.....	6-3
•Fan hub - check.....	6-11
•Belt tensioner bearing - check.....	6-9
•Belt tension - check.....	6-11
•Vibration damper - inspect.....	7-7
•Coolant and antifreeze - change.....	7-3
•Charge Air Cooler - leak check (320,000 Km/200,000 Mi).....	A-87

Section 3-Daily Maintenance Procedures

Section Contents

	Page
Coolant Level	3-4
Check.....	3-4
Cooling Fan	3-6
Inspection.....	3-6
Drive Belt	3-5
Inspection.....	3-5
Fuel-Water Separator	3-3
Draining.....	3-3
General Information	3-2
Oil Level	3-3
Check.....	3-3

General Information

Preventative maintenance begins with day-to-day awareness of the condition of the engine and its systems.

Before starting the engine, check the oil and coolant levels. Look for:

- Leaks
- Loose or damaged parts
- Worn or damaged belts
- Any change in engine appearance

Section 3-Daily Maintenance Procedures B Series

Fuel-Water Separator

Draining

Draining the water and sediment from the separator daily. Shut off the engine. Use your hand to open the drain valve. Turn the valve **counterclockwise** approximately 1 1/2-to 2 turns until draining occurs. Drain the filter sump of water until clear fuel is visible.

Caution: Do not overtighten the valve. Overtightening can damage the threads.

Turn the valve **clockwise** to close the drain valve.

Oil Level

Check

Never operate the engine with the oil level below the "L" (Low) mark or above the "H" (High) mark. Wait at least 5 minutes after shutting off the engine to check the oil. This allows time for the oil to drain to the oil pan.

NOTE: The engine **must** be level when checking the oil level to make sure the measurement is correct.

Low Mark To High Mark Oil Capacity

4 Cylinder-0.95 Liter [1.0 U.S. Quart]

6 Cylinder-1.89 Liter [2.0 U.S. Quart]

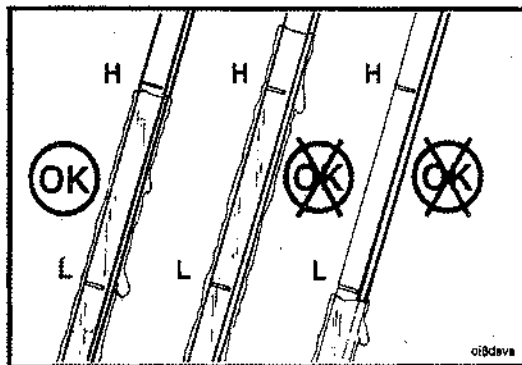
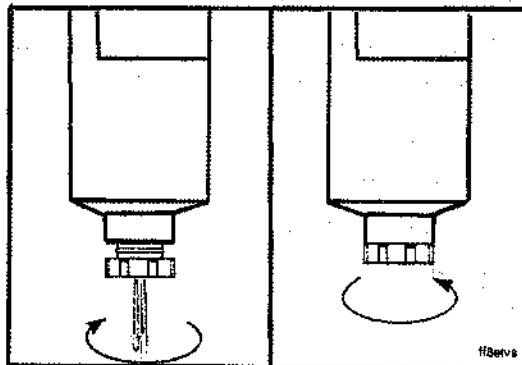

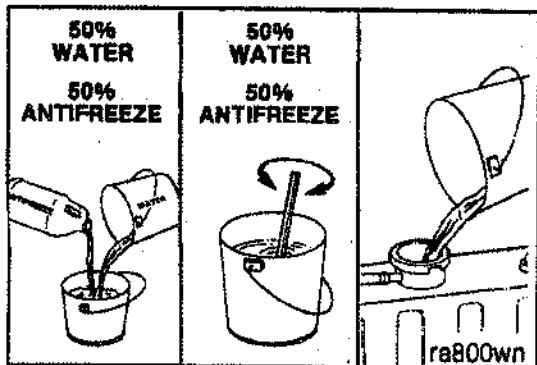
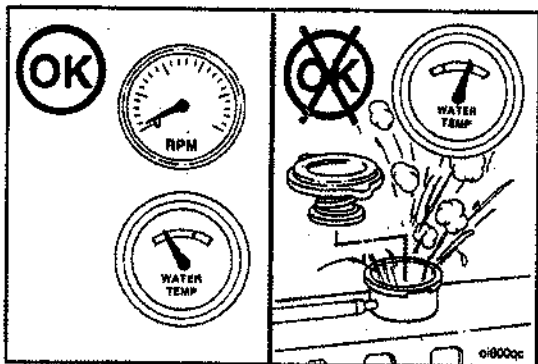

Coolant Level

Check



Warning: Do not remove the radiator cap from a hot engine. Wait until the temperature is below 50 °C [120 ° F] Before removing the pressure cap. Failure to do so can result in personal injury from heated coolant spray or steam. Remove the filler cap slowly to relieve coolant system pressure.

NOTE: Never use a sealing additive to stop leaks in the coolant system. This can result in coolant system plugging and inadequate coolant flow causing the engine to overheat.



The coolant level **must** be checked daily.



Caution: Do not add cold coolant to a hot engine. Engine castings can be damaged. Allow the engine to cool to below 50 °C [120 °F] before adding coolant.

NOTE: On applications that use a coolant recovery system, check to make sure the coolant is at the appropriate level on the coolant recovery tank depending on engine temperature.

Section 3-Daily Maintenance Procedures B Series

Drive Belt
Page 3-5

Fill the cooling system with coolant to the bottom of the fill neck in the radiator fill or expansion tank.

NOTE: Some radiators have two fill necks, both of which **must** be filled when the cooling system is drained.

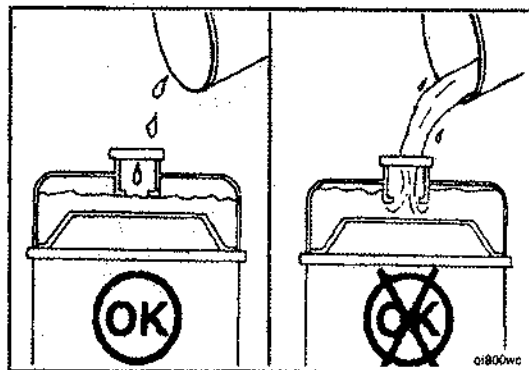

Drive Belt

Inspection

Visually inspect the belt. Check the belt for intersecting cracks. Transverse (across the belt width) cracks are acceptable. Longitudinal (direction of belt length) cracks that intersect with transverse cracks are **not** acceptable. Replace the belt if it is frayed or has pieces of material missing. Refer to **Adjustment and Replacement** (Section A).

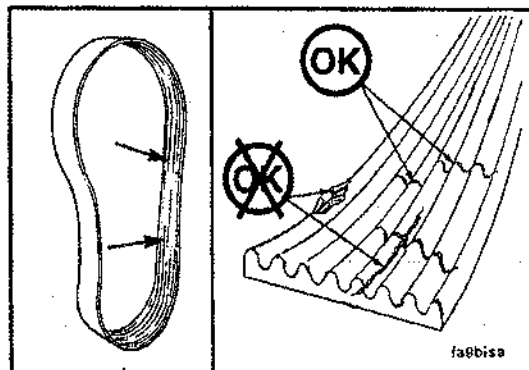

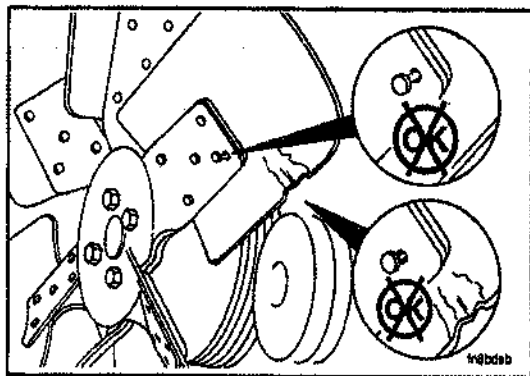

Cooling Fan

Inspection



Warning: Personnel injury can result from a fan blade failure. Never pull or pry on the fan. This can damage the fan blade (s) and cause fan failure.

NOTE: Rotate the crankshaft by using the engine barring gear.



A visual inspection of the cooling fan is required daily. Check for cracks, loose rivets, and bent or loose blades. Check the fan to make sure it is securely mounted. Tighten the capscrews if necessary. Replace any fan that is damaged.

Section 4-Maintenance Procedures at 10,000 Kilometers [6,000 Miles], 250 Hours or 3 Months

Section Contents

	Page
Air Cleaner Restriction	4-13
Check.....	4-13
Air Intake System	4-10
Charge Air Cooler.....	4-11
Inspection.....	4-10
General Information	4-2
Lubricating Oil and Filter	4-4
Changing.....	4-4
Lubricating Oil and Filter Change Interval	4-2

General Information

All checks or inspections listed under daily or previous maintenance intervals **must** also be performed at this time in addition to those listed under this maintenance interval.

Lubricating Oil and Filter Change Interval

Refer to the following flow chart to determine the **maximum** recommended oil and filter change intervals in kilometers, milse, hours or months; whichever comes first.

Maintenance Procedures at 10,000 Km [6,000 Mi] B Series

Lubricating Oil and Filter Change Interval Page 4-3

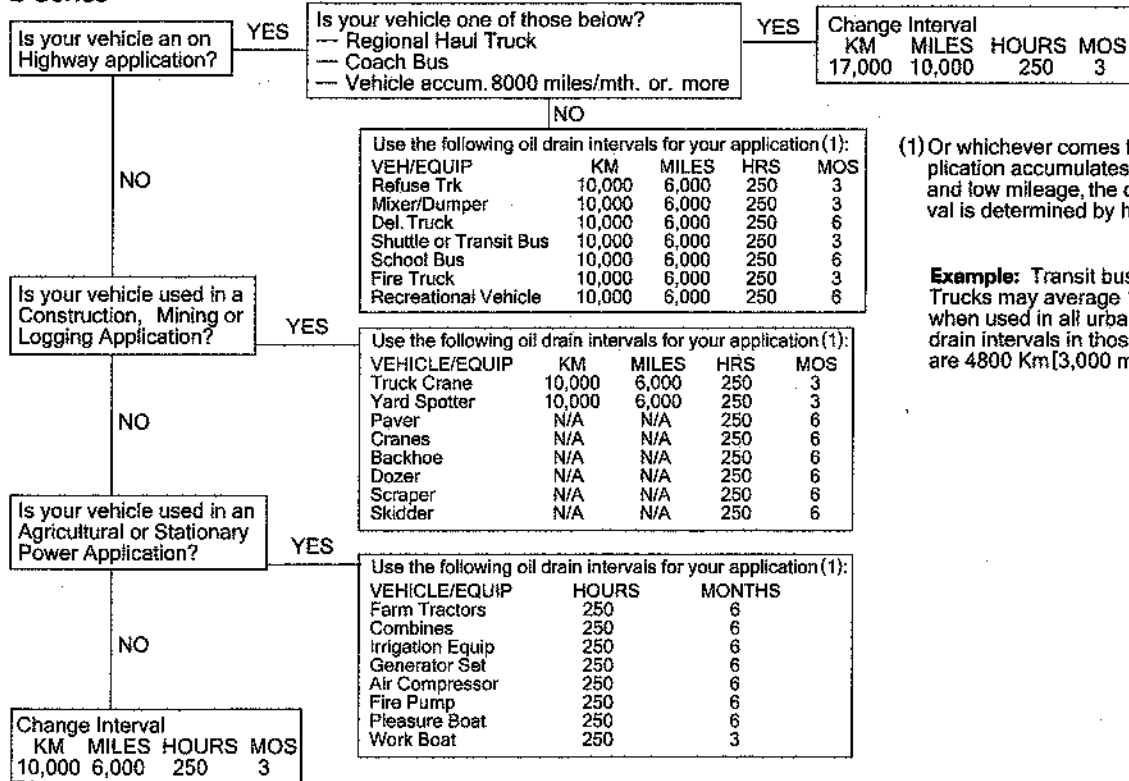

(1) Or whichever comes first. If your application accumulates high hours and low mileage, the change interval is determined by hours.

Example: Transit buses and refuse Trucks may average 16 Km [10 MPH] when used in all urban routes. Oil drain intervals in those applications are 4800 Km [3,000 mi], or less.

Lubricating Oil and Filter

Changing



Caution: Avoid prolonged and repeated skin contact with used engine lubricating oils. Such prolonged and repeated contact may cause skin disorders or other bodily injury.

- Avoid excessive contact-wash thoroughly after contact.
- Keep out of reach of children.

PROTECT THE ENVIRONMENT: Handling and disposal of used engine lubricating oil may be subject to federal, state and local law and regulation. Use authorized waste disposal facilities, including civic amenity sites and garages providing authorized facilities for receipt of used lubricating oil. If in doubt, contact your state and local environmental authorities or the Environmental Protection Agency for guidance as to proper handling and disposal of used engine oil.

Maintenance Procedures at 10,000 Km [6,000 Mi] B Series

NOTE: If the engine is service, the oil drain interval of 10,000 Km [6,000 miles] 250 hours or 3 months (or approved extended interval from the Chart on Page 4-3) **must** be observed.

Change the oil and filters to remove the contaminants suspended in the oil.

NOTE: Drain the oil only when it is hot and the contaminants are in suspension.

17mm

Caution: Hot oil can cause personal injury

Operate the engine until the water temperature reaches 60°C [140°F]. Shut the engine off. Remove the oil drain plug.

NOTE: Use a container that can hold at least 20 liters [15 U.S. qts.] of oil.

Lubricating Oil and Filter Page 4-5

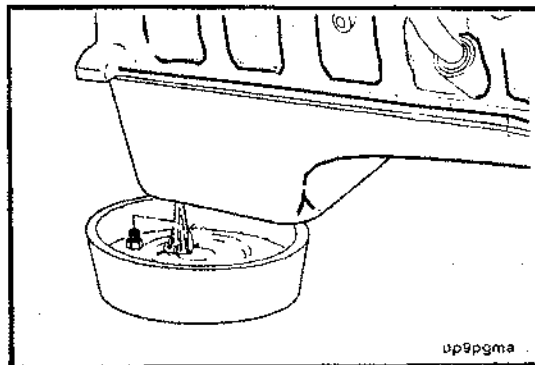
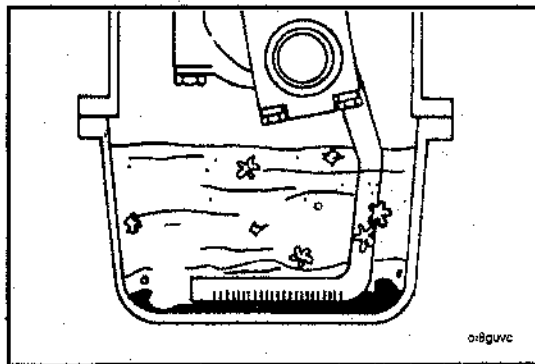

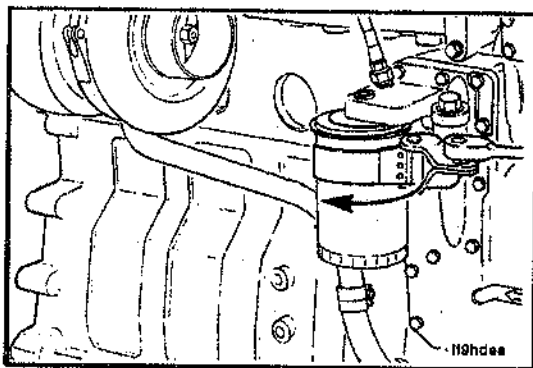

90 to 95 mm Filter Wrench

Clean the area around the lubricating oil filter head. Remove the filter. Clean the gasket surface of the filter head.

NOTE: The o-ring can stick on the filter head. Make sure it is removed before installing the new filter.

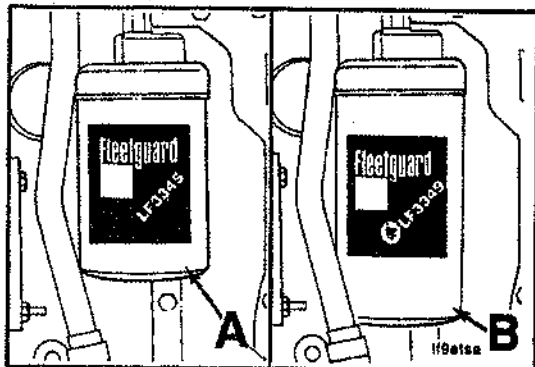

Make sure the correct oil filter is used.

The filter for the six-cylinder engine is longer than the filter for the four-cylinder engine.

A = Standard for four-cylinder applications.

B = Standard for six-cylinder applications.

NOTE: A 6 cylinder oil filter can be used on a 4 cylinder engine. **Do not** use a 4 cylinder oil filter on a 6 cylinder engine.

Maintenance Procedures at 10,000 Km [6,000 Mi] B Series

NOTE: Fill the filters with clean lubricating oil before installation.

Apply a light film of lubricating oil to the gasket sealing surface before installing the filters.

Caution: Mechanical over-tightening can distort the threads or damage the filter element seal.

Install the filter as specified by the filter manufacturer.

Lubricating Oil and Filter Page 4-7

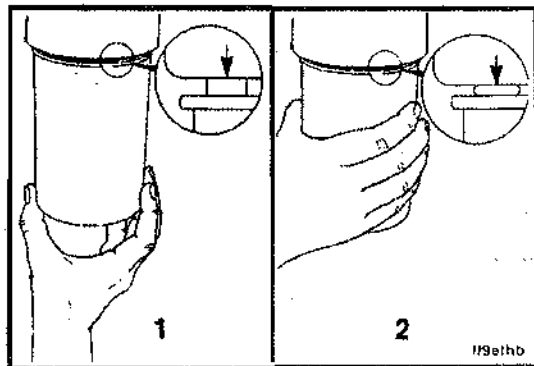
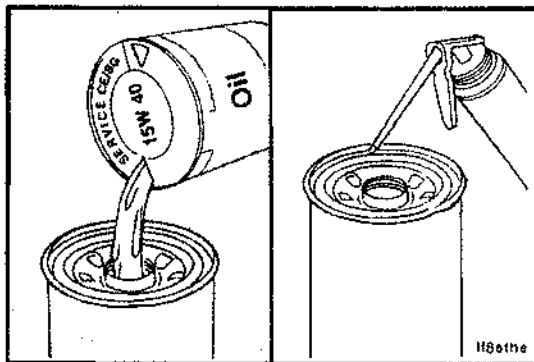

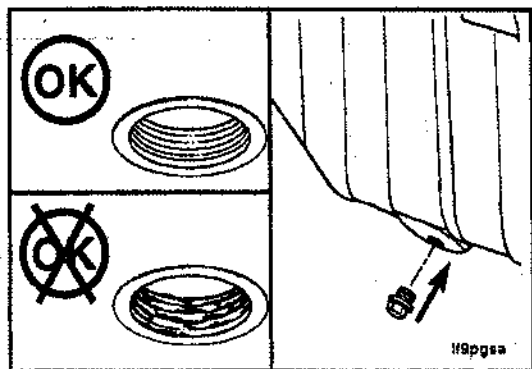

17 mm

Check and clean the oil drain plug threads and sealing surface.



Install the oil drain plug.



Torque Value: 80 N•m [60 ft-lb]



NOTE: Use high quality multi-grade lubricating oil meeting the American Petroleum Institute (API) classification of CE/SG as outlined in Specifications and Torque Values (Section V).



NOTE: CD/SF oil can be used in areas where CE/SG oil is not yet available.

If CD/SF oil is used, change the oil at one-half the recommended intervals.

Maintenance Procedures at 10,000 Km [6,000 Mi] B Series

Lubricating Oil and Filter
Page 4-9

Fill the engine with clean oil to the proper level.

	Four Cylinder	Six Cylinder
Pan Capacity	9.5 Liters [10 U.S. Qts]	14.2 Liters [15 U.S. Qts]
Total System	10.9 Liters	16.3 Liters
Capacity	[11.5 U.S. Qts]	[17.2 U.S. Qts]

NOTE: Capacities assume standard pan. Total system assumes standard pan plus filter.

Some 6B applications use a reduced capacity pan 10.4 Liters [11 U.S. Qts] and some have increased capacity of 16 liters [17 U.S. Qts]. Fill quantities **must** be adjusted accordingly.

Operate the engine at idle to inspect for leaks at the filters and the drain plug.

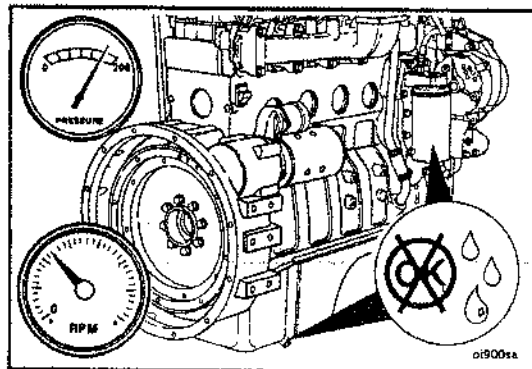
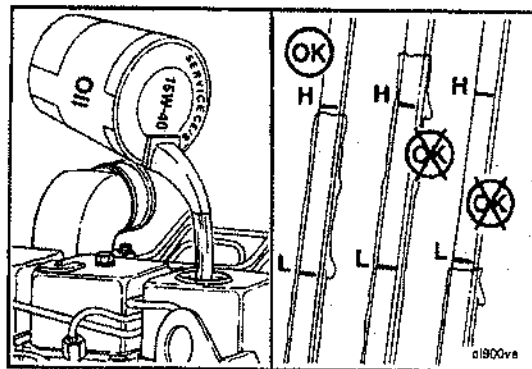

Lubricating Oil and Filter

Page 4-10

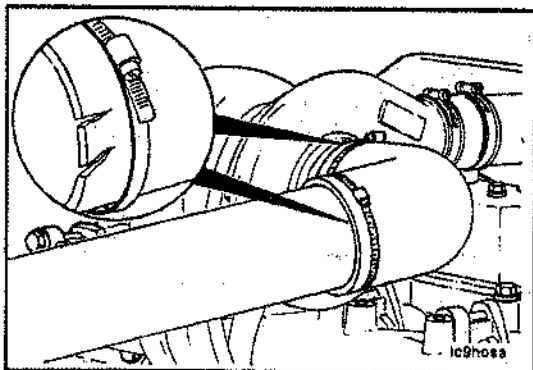
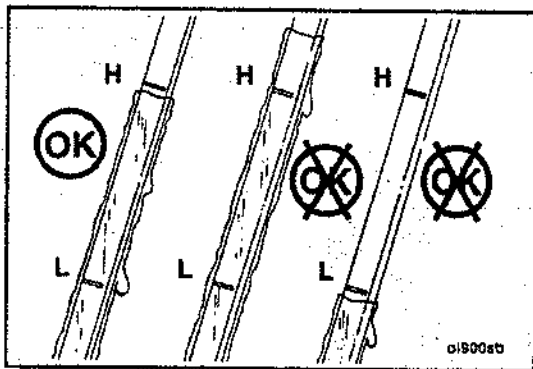

Maintenance Procedures at 10,000 Km [6,000 Mi] B Series



Stop the engine. Wait approximately 5 minutes to let the oil drain from the upper parts of the engine. Check the oil level again.

Add oil as necessary to bring the oil level to the "H" (High) mark on the dipstick.



Air Intake System

Inspection

Inspect the intake piping for cracked hoses, loose clamps, or punctures which can allow dirt and debris to enter the engine.

Tighten or replace parts as necessary to make sure the air intake system does not leak.

Maintenance Procedures at 10,000 Km [6,000 Mi] B Series

Charge Air Cooler

Inspection

If the engine experiences a turbocharger failure or any other occasion where oil or debris is put into the CAC, the CAC must be cleaned.

Remove the CAC from the vehicle. Refer to the vehicle manufacturer's instructions.

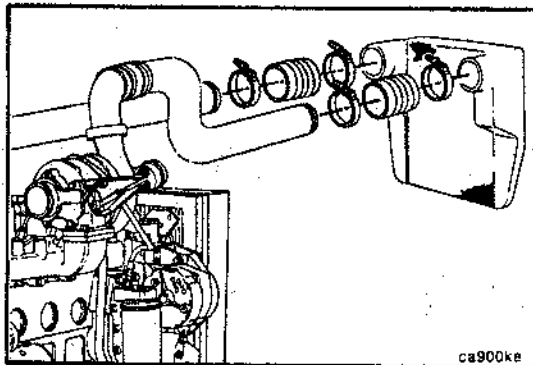

Visually inspect the CAC for cracks, holes or damage.

Inspect the tubes, fins and welds for tears, breaks or other damage.

Refer to Section A to find the leak check procedure.

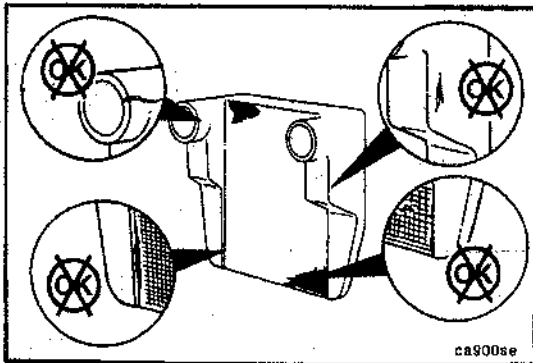

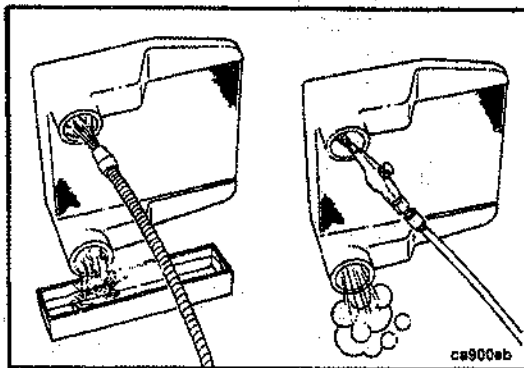
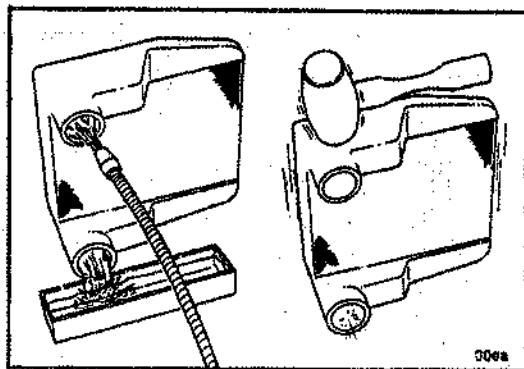

Cleaning



Flush the CAC internally with solvent in the opposite direction of normal air flow. Shake the CAC and lightly tap on the end tanks with a rubber mallet to dislodge trapped debris. Continue flushing until all debris or oil is removed.



Caution: Do not use caustic cleaners to clean the CAC. Damage to the CAC will result.



After the CAC has been thoroughly cleaned of all oil and debris with solvent, wash the CAC internally with hot soapy water to remove the remaining solvent. Rinse thoroughly with clean water.

Blow compressed air into the CAC in the opposite direction of normal air flow until the CAC is dry internally.



Refer to the vehicle manufacturer's instructions for installation procedures.

Air Cleaner Restriction

Check

Maximum intake air restriction is 635 mm [25.0 in.] of water for turbocharged engines. Naturally aspirated engines have a maximum restriction of 510 mm [20.0 in.] of water.

Turbocharged engines must be operated at rated RPM and full load to check maximum intake air restriction. Replace the air cleaner element when the restriction reaches the maximum allowable limit or clean according to the manufacturer's recommendations.

NOTE: Follow the manufacturer's instructions when cleaning or replacing the air cleaner element.

Check the air cleaner service indicator, if equipped. Change the filter element when the red indicator flag (2) is at the raised position in the window. (1)

After the air cleaner has been serviced, push the button (3) to reset the service indicator.

NOTE: Never operate the engine without an air cleaner. Intake air must be filtered to prevent dirt and debris from entering the engine and causing premature wear.

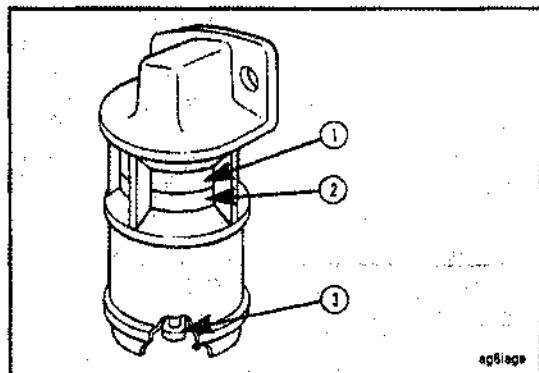
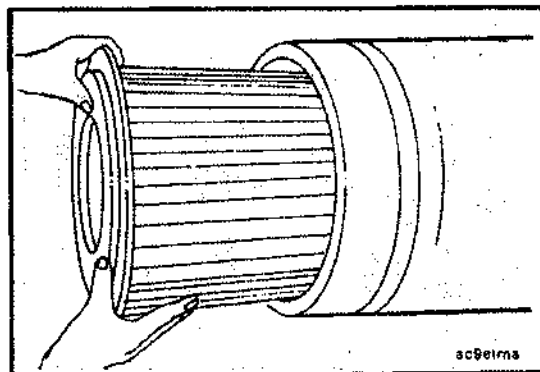

Section 5-Maintenance Procedures at 19,000 Kilometers [12,000 Miles], 500 Hours or 6 Months

Section Contents

	Page
Antifreeze Concentration.....	5-9
Check.....	5-9
Fuel Filter.....	5-3
Replacement.....	5-3
Fuel System.....	5-4
Bleeding.....	5-4
General Information.....	5-2
High Pressure Lines (Rotary and.....	5-8
Re-Tighten Line Fittings.....	5-8
Venting.....	5-8
Injection Pump.....	5-6
Venting.....	5-6
Low Pressure Lines and Fuel filter (s).....	5-5
Venting.....	5-5

General Information

All checks or inspections listed under daily or previous maintenance intervals **must** also be performed at this time in addition to those listed under this maintenance interval.

Fuel Filter

Replacement

75-80 mm and 90-95 mm

Clean the area around the fuel filter head. Remove the filters. Clean the gasket surface of the filter head.

Replace the o-ring.

Fill the new filter (s) with clean fuel and lubricate the o-ring seal with clean lubricating oil.

- Standard filter - used as secondary filter in dual filter applications.
- Fuel water separator - used as primary filter in dual filter applications.
- Fuel water separator - used in single filter applications.

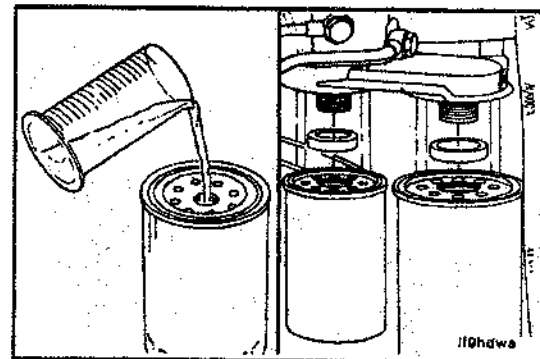
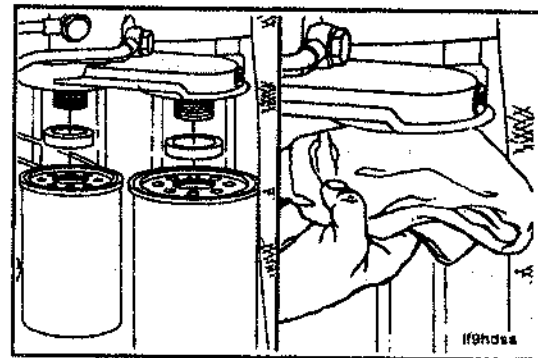

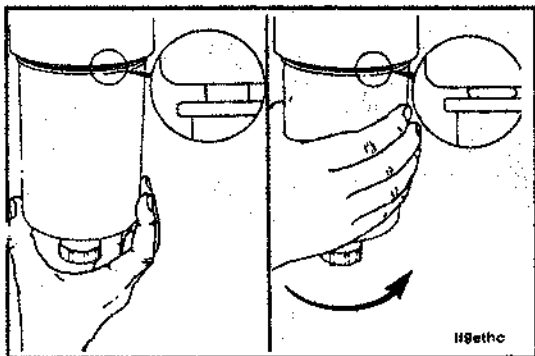

Caution: Mechanical tightening will distort the threads, filter element seal or filter can.

Install the filter as specified by the filter manufacturer.

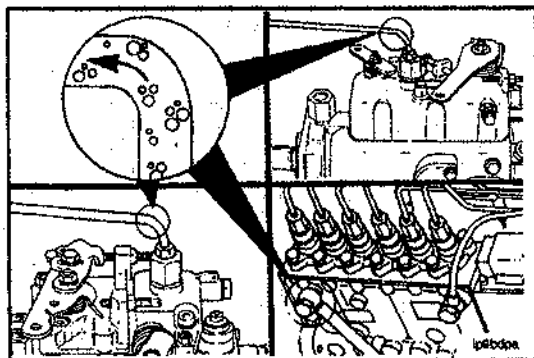

Fuel System

Bleeding

Controlled venting is provided at the injection pump through the fuel drain manifold. Small amounts of air introduced by changing the filters or injection pump supply line will be vented automatically, if the fuel filter is changed in accordance with the instructions. No manual bleeding of fuel lines is required.

Maintenance Procedures at 19,000 Km [12,000 Mi] B Series

NOTE: Manual bleeding is required if:

- The fuel filter is not filled prior to installation.
- Injection pump is replaced.
- High pressure fuel line connections are loosened or lines replaced.
- Initial engine start up or start up after an extended period of no engine operation.
- Vehicle fuel tank has run empty.

Low Pressure Lines and Fuel Filter (s)

Venting

8 mm

open the vent screw.

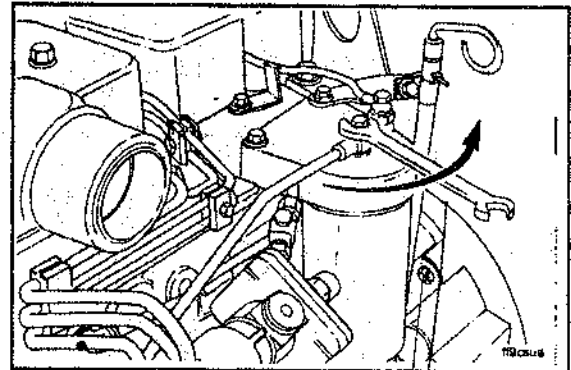

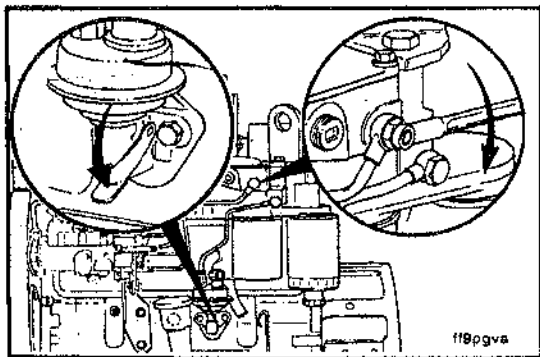

Operate the plunger on the lift pump until the fuel flowing from the fitting is free of air.

Tighten the bleed screw.



Torque Value: 9 N•m [7 ft-lb]

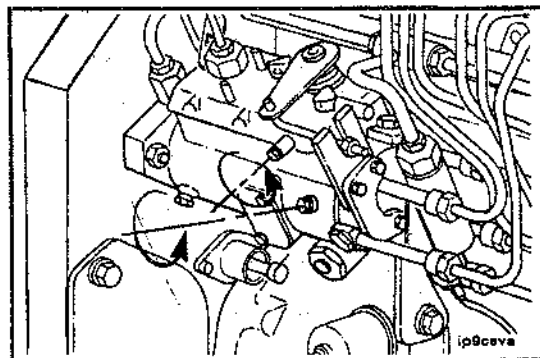

Injection pump

Venting

8 mm

Bleed the Lucas CAV pump at the location shown in the illustration.

Maintenance Procedures at 19,000 Km [12,000 Mi] B Series

Air/fuel can be pumped from this location with the hand lever on the lift pump if the fuel solenoid valve is energized.

Injection pump
Page 5-7

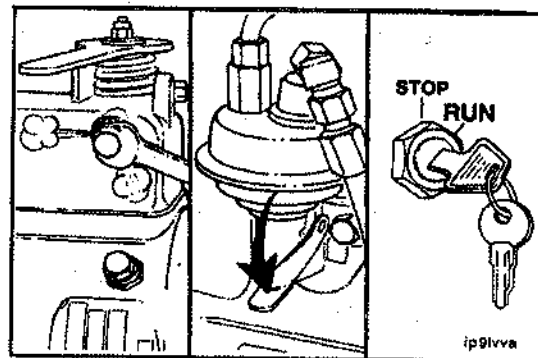

Air can be vented from both pumps through the fuel drain manifold line by operating the starting motor.

Caution: When using the starting motor to vent the system, do not engage it for more than 30 seconds at a time: Wait 2 minutes between engagements.

Warning: It is necessary to put the engine in the "Run" position. Because the engine may start, be sure to follow all the safety precautions. Use the normal engine starting procedure.

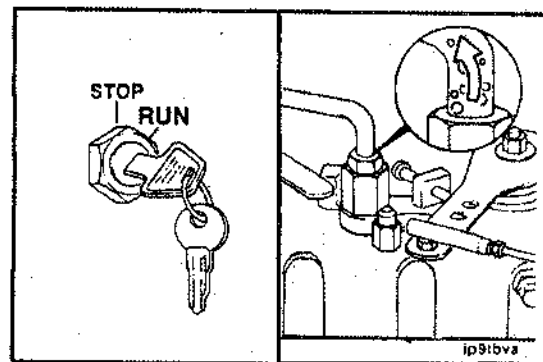

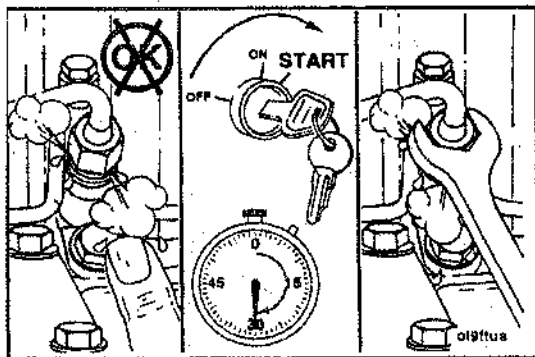

High Pressure Lines (Rotary and- In-line Pumps)

Venting



17 mm, 19 mm



Warning: The pressure of the fuel in the line is sufficient to penetrate the skin and cause serious bodily harm.

Venting is accomplished by loosening one or more fittings at the injectors and cranking the engine to allow entrapped air to bleed from the lines.

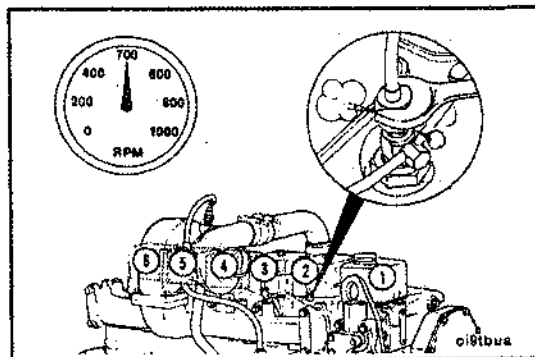

Re-Tighten Line Fittings



Torque Value: 30 N·m [22 ft·lb]



Warnig: Do not bleed a hot engine as this could cause fuel to spill onto a hot exhaust manifold creating a danger of fire.

Start the engine and vent one line at a time until the engine runs smoothly.

Antifreeze Concentration

Check

Check the antifreeze concentration. Use a mixture of 50 percent water and 50 percent ethylene-glycol base antifreeze to protect the engine to -37°C [-34°F] year around.

Antifreeze is essential in any climate.

It broadens the operating temperature range by lowering the coolant freezing point and by raising its boiling point.

The corrosion inhibitors also protects the cooling system components from corrosion and provides longer component life.

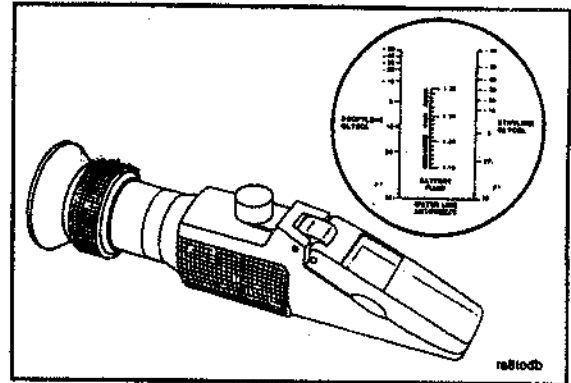

10/10/1944

10/10/1944

10/10/1944



10/10/1944

10/10/1944

Section 6-Maintenance Procedures at 38,000 Kilometers [24,000 Mi.], 1000 Hours or 1 Year

Section Contents

	Page
Drive Belt	6-10
Inspection	6-10
Drive Belt Tension	6-9
Check	6-9
General Information	6-2
Valves	6-3
Adjustment	6-3
Four-Cylinder Engine Adjustment	6-5
Six-Cylinder Engine Adjustment	6-7

General Information

All checks or inspections listed under daily or previous maintenance intervals must also be performed at this time in addition to those listed under this maintenance interval.

The procedures given in this section for valve lash adjustment are to be performed at the initial 38,000 km [24,000 mi] adjustment. Subsequent adjustments are to be performed at 77,000 km [48,000 mi] intervals.

**Maintenance Procedures at 38,000 Km [24,000 Mi.]
B Series**

Valves

Adjustment

15 mm

Remove the valve cover.

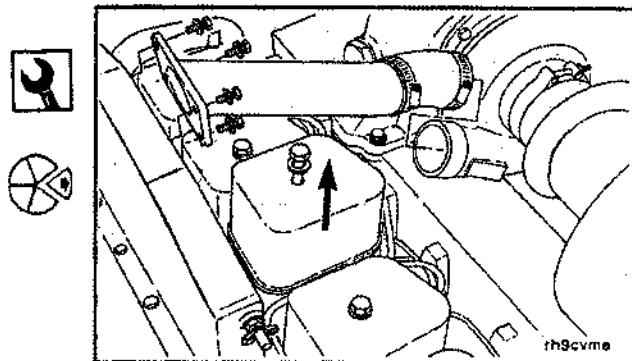

1/2 Inch Drive, 3377371 Engine Barring Gear

Locate Top Dead Center (TDC) for Cylinder Number 1 by barring engine slowly while pressing on the engine timing pin.

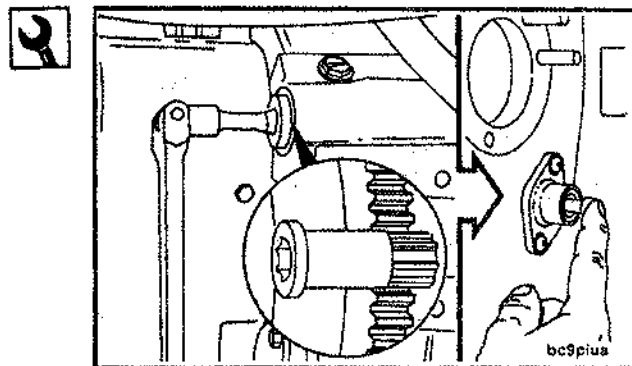

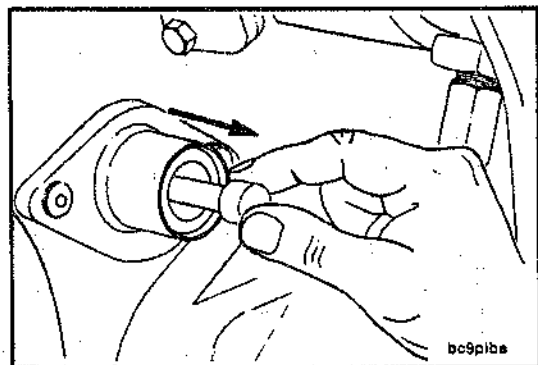
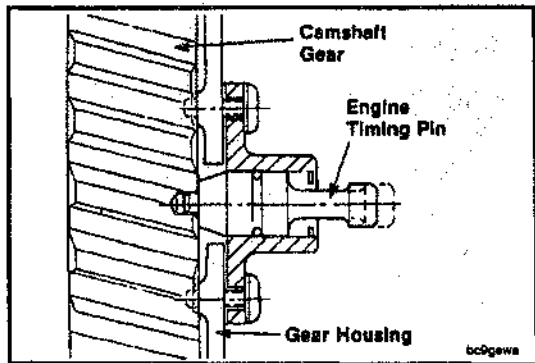

**Maintenance procedures at 38,000 Km [24,000Mi.]
B Series**

When the pin engages the hole in the camshaft gear, cylinder Number 1 is at TDC on the compression stroke.



Caution: To prevent damage to the engine or pin, be sure to disengage the pin after locating TDC.

Maintenance Procedures at 38,000 Km [24,000 Mi.] B Series

Valves
Page 6-5

Feeler Gauge

Intake Clearance: 0.254 mm [0.010 IN]

Exhaust Clearance: 0.508 mm [0.020 IN]

Check/set valves with engine cold-**below** 60°C [140°F].

NOTE: The clearance is correct when some resistance is "felt" when the feeler gauge is slipped between the valve stem and the rocker lever.

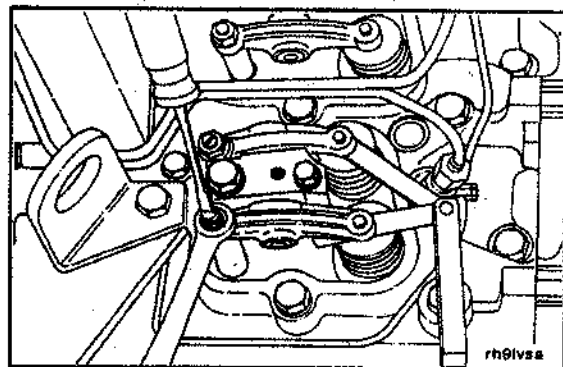

Four Cylinder Engine Adjustment

14 mm, Flatblade Screwdriver

Locate Top Dead Center (TDC) for Cylinder Number 1.

Check / adjust the valves as indicated in the illustration (1 = Intake; E = Exhaust).

Tighten the locknut and measure the valve lash again.

Torque Value: 24 N•m [18 ft-lb]

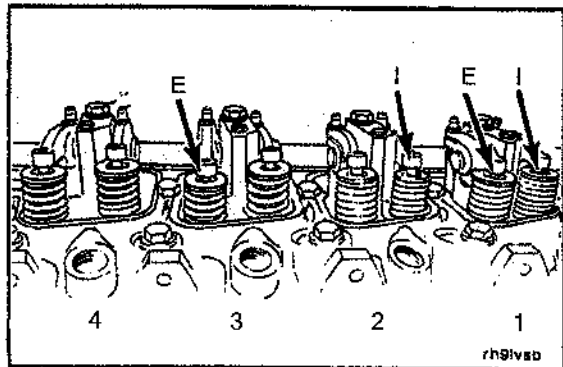

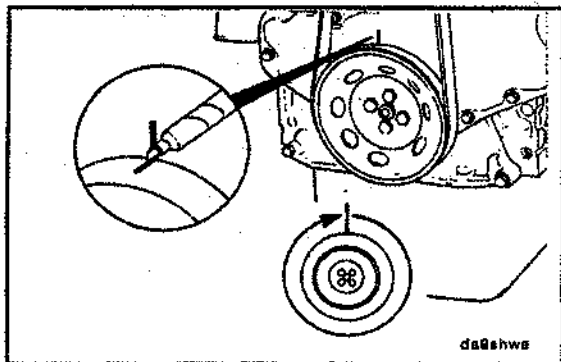

Mark the pulley and rotate the crankshaft 360 degrees.

Caution: To prevent engine or pin damage, be sure timing is disengaged.

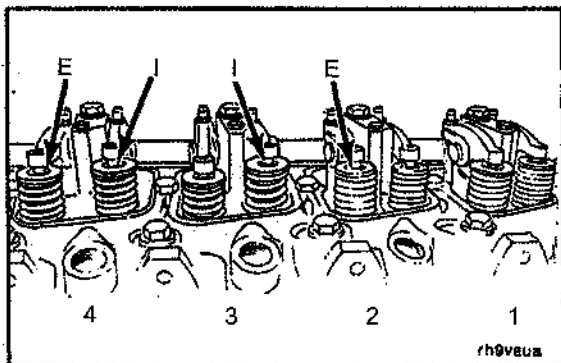

14 mm, Flatblade Screwdriver

Adjust the valves as indicated in the illustration.

Tighten the lock nut and measure the valve lash again.



Torque Value: 24 N·m [18 ft·lb]

Maintenance Procedures at 38,000 Km [24,000 Mi.]
B Series

Six-Cylinder Engine Adjustment

14 mm, Flatblade Screwdriver

Locate Top Dead Center (TDC) for Cylinder Number 1.

Check / adjust the valves as indicated in the illustration
(I = Intake; E = Exhaust).

Tighten the locknut and measure the valve lash again.

Torque Value: 24 N·m [18 ft-lb]

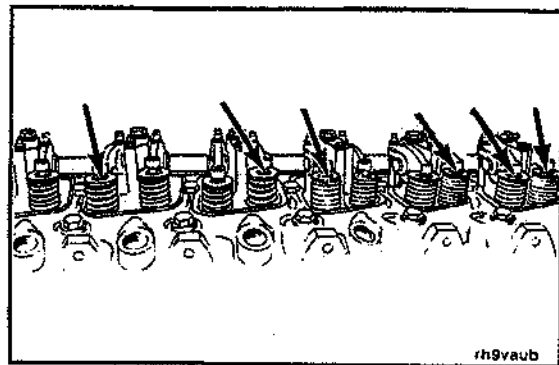

Mark the pulley / vibration damper and rotate the crankshaft 360 degrees.

Caution: To prevent engine or pin damage, be sure timing pin is disengaged.

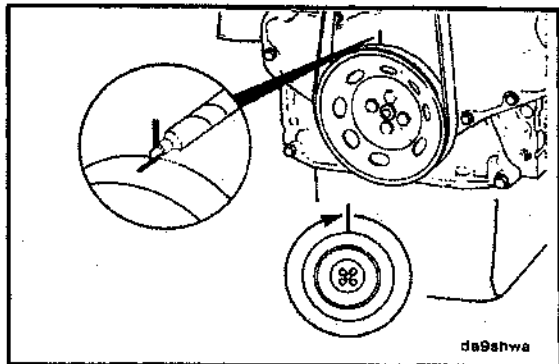

Valves
page 6-8

Maintenance procedures at 38,000 Km [24,000Mi.]
B Series

Adjust the valves as indicated in the illustration.
Tighten the lock nut and measure the valve lash again.

Torque Value: 24 N·m [18 ft·lb]

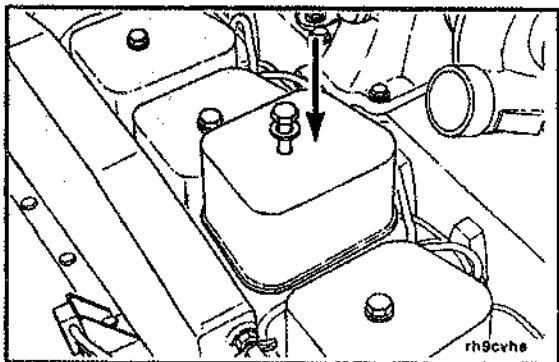
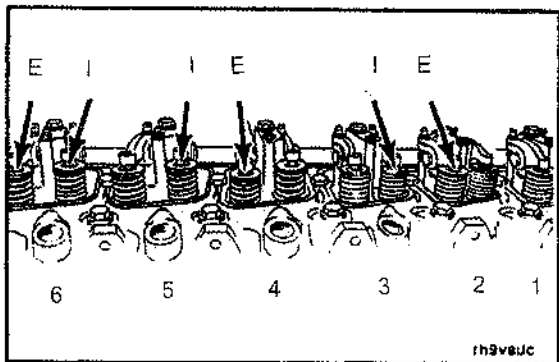

15 mm

Install the valve covers and tighten capscrews.

Torque Value: 24 N·m [18 ft·lb]

Drive Belt Tension

Check

Measure the belt deflection at the longest span of the belt.

Maximum Deflection: 9.5 to 12.7 mm [3/8 to 1/2 inch]

NOTE: The Cummins belt tension gauge, Part No. ST-1293 can be used.

Gauge Value: 267 to 578 N [60 to 130 Lbf]

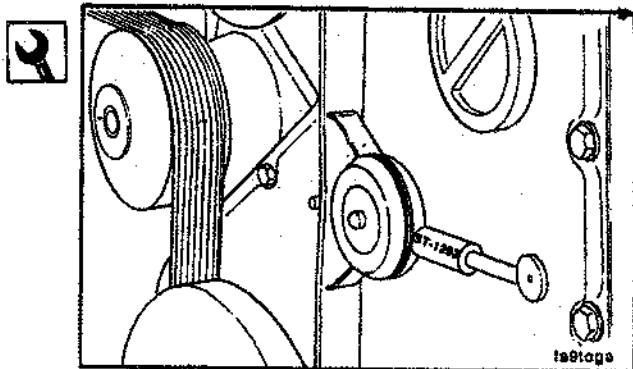
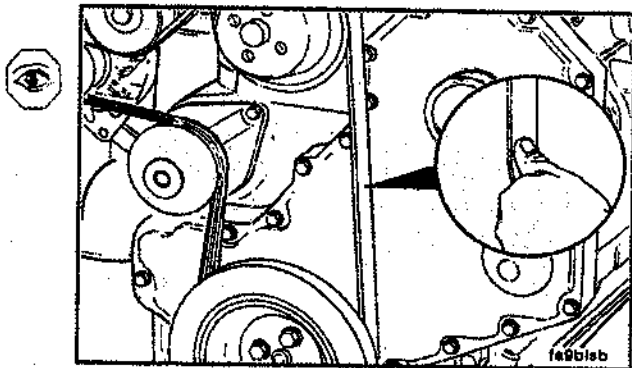



Drive Belt



Inspection

3/8 Inch Square Drive, 13 mm



Remove the drive belt.



Lift the tensioner to remove and install the belt.

NOTE: After the tensioner has been raised to remove/install the belt, check the torque of the tensioner capscrew.

Torque Value: 43 N•m [32 ft-lb]

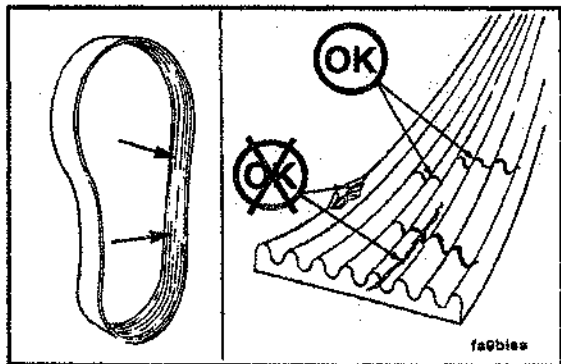

Inspect the belt for damage.

Transverse (across the belt width) cracks are acceptable. Longitudinal (direction of belt length) cracks that intersect with Transverse cracks are **not** acceptable.

Replace the belt if it has unacceptable cracks, if frayed or has pieces of material missing.

Section 7-Maintenance Procedures at 77,000 Kilometers [48,000 Mi.], 2000 Hours or 2 Year

Section Contents

	Page
Cooling System Maintenance	7-3
Coolant Draining.....	7-3
Coolant System Filling.....	7-7
Coolant System Flushing.....	7-5
General Information	7-2
Vibration Damper(Rubber)	7-9
Inspection.....	7-9

General Information

All checks or inspections listed under daily or previous maintenance intervals **must** also be performed at this time in addition to those listed under this maintenance interval.

Cooling System Maintenance

Coolant draining

Caution: Avoid prolonged and repeated skin contact with used antifreeze. Such prolonged repeated contact can cause skin disorders or other bodily injury.

- Avoid excessive contact-wash thoroughly after contact.
- Keep out of reach of children.

Protect the environment: Handling and disposal of used antifreeze can be subject to federal, state, and local law regulation. Use authorized waste disposal facilities, including civic amenity sites and garages providing authorized facilities for the receipt of used antifreeze. If in doubt, contact your local authorities or the EPA for guidance as to proper handling of used antifreeze.

Caution: Wait until the temperature is below 50 °C [120 °F] before removing the coolant system pressure cap. Failure to do so can cause personal injury from heated coolant spray.

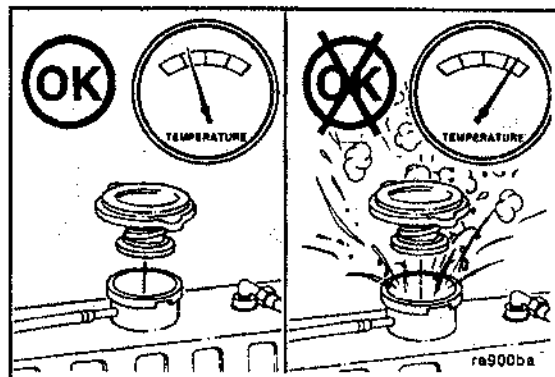

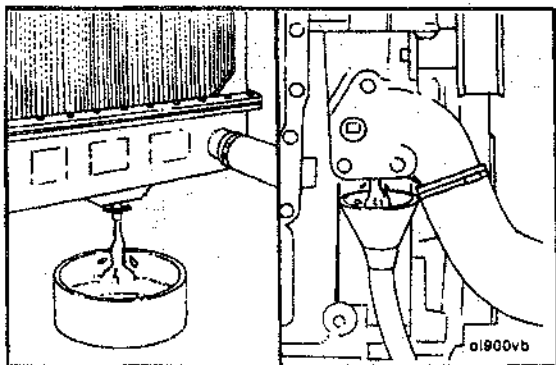

Drain the cooling system by opening the drain valve on the radiator and removing the plug in the bottom of the water inlet. A drain pan with a capacity of 20 liters [5 U.S. gallons] will be adequate in most applications.

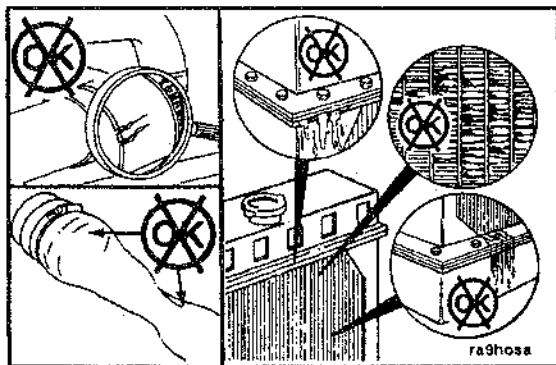

Check for damaged hoses and loose or damaged hose clamps. Replace as required. Check the radiator for leaks, damage and build up of dirt. Clean and repair as required.

Cooling System Flushing

Caution: During filling, air must be vented from the engine coolant passages. Open the engine venting petcock and the petcock on the aftercooler for aftercooled engines. The system must be filled slowly to prevent air locks. Wait 2 to 3 minutes to allow air to be vented, then add mixture to bring the level to the top.

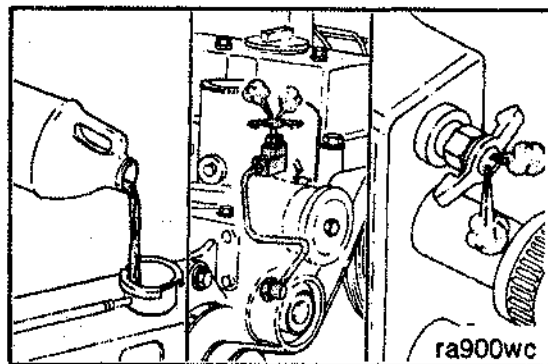

Fill the system with a mixture of sodium carbonate and water (or a commercially available equivalent).

NOTE: Use 0.5 kilogram [1.0 pound] of sodium carbonate for every 23 liters [6.0 U.S. gallons] of water.

Caution: Do not install the radiator cap. The engine is to be operated without the cap for this process.

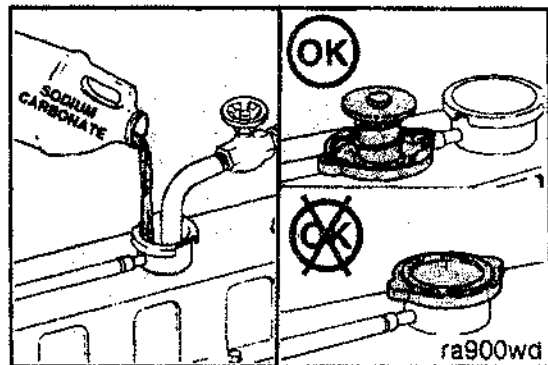

Cooling System Maintenance
page 7-6

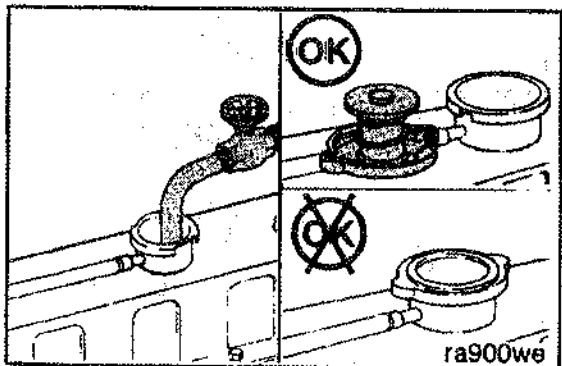
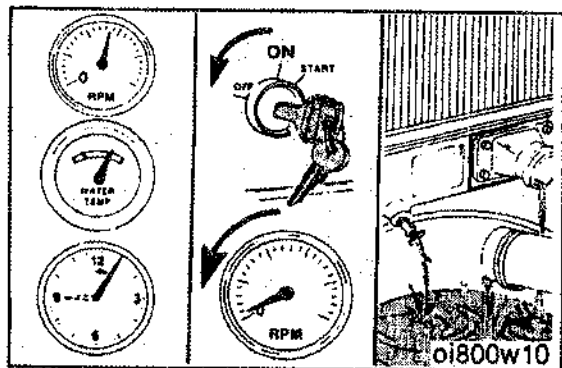

Maintenance procedures at 77,000 Km [48,000Mi.]
B Series

Operate the engine for 5 minutes with the coolant temperature above 80°C [176°F].

Shut the engine off and drain the cooling system.

Fill the cooling system with clean water.

NOTE: Be sure to vent the engine and aftercooler for complete filling.

NOTE: Do not install the radiator cap or the new coolant filter.

Maintenance procedures at 77,000 Km [48,000Mi.] B Series

Operate the engine for 5 minutes with the coolant temperature above 80°C [176°F].

Shut the engine off and drain the cooling system.

NOTE: If the water being drained is still dirty, the system must be flushed again until the water is clean.

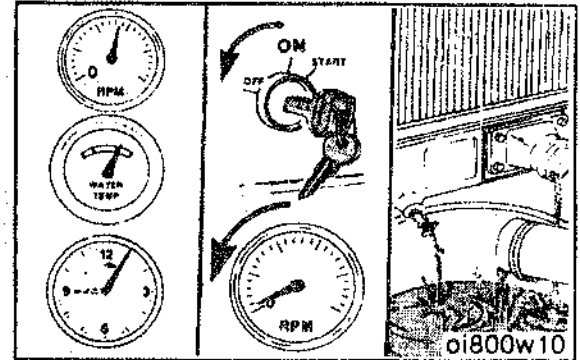

Coolant System Filling

The system has a maximum fill rate of 14 liters per minute [3.5 U.S. Gallons per minute]. **Do not exceed this fill rate.**

Caution: The system must be filled slowly to prevent air locks. During filling, air must be vented from the engine coolant passages. Be sure to open the petcock on the aftercooler for aftercooled engines. Wait 2 to 3 minutes to allow air to be vented, then add mixture to bring the level to the top.

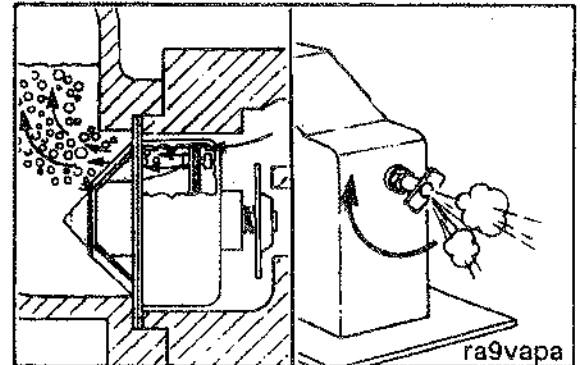

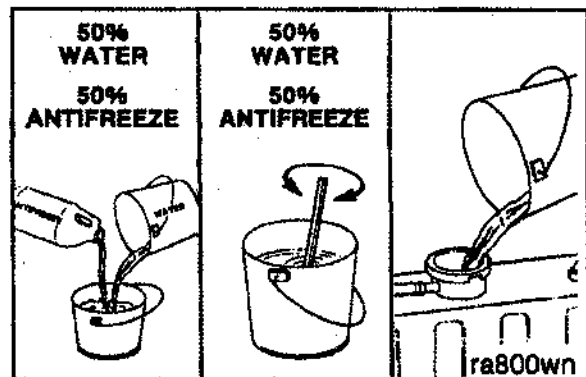

Use a mixture of 50 percent water and 50 percent ethylene glycol antifreeze to fill the cooling system.

Coolant Capacity (Engine Only)		Liter [U.S. Quarts]	
4B3.9		6B5.9	
4BT3.9	4BTA3.9*	6BT5.9	6BTA5.9*
7.0 [7.4]	7.9 [8.4]	9 [9.5]	9.9 [10.5]

*4BTA and 6BTA engines use a jacket-water aftercooler. If a Charge Air Cooler is used, the coolant capacity is the same as the naturally aspirated or turbocharged only engines.



Caution: Never use water alone for coolant. Damage from corrosion can be the result of using water alone for coolant.

Maintenance procedures at 77,000 Km [48,000Mi.] B Series

Install the pressure cap. Operate the engine until it reaches a temperature of 80°C [180°F], and check for coolant leaks.

Check the coolant level again to make sure the system is full of coolant, or that the coolant level has risen to the hot level in the recovery bottle on the system, if so equipped.

Warning: Before removing the pressure cap, wait until the coolant temperature is below 50°C [120°F]. Failure to do so can cause personal injury from heated coolant spray.

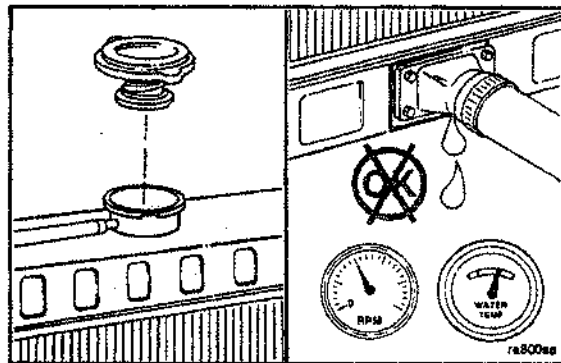

Vibration Damper (Rubber)

Inspection

Check the index lines (A) on the damper hub (B) and the inertia member (C). If the lines are more than 1.59 mm [1/16 inch] out of alignment, replace the damper.

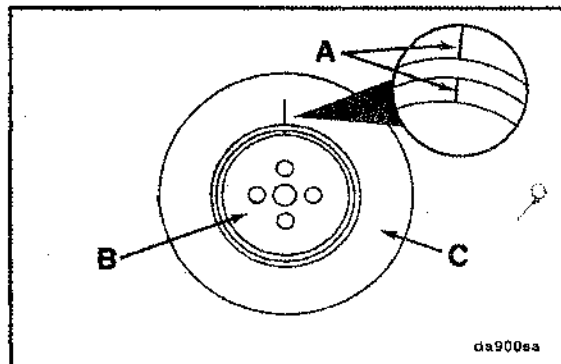

Vibration Damper (Rubber)
page 7-10

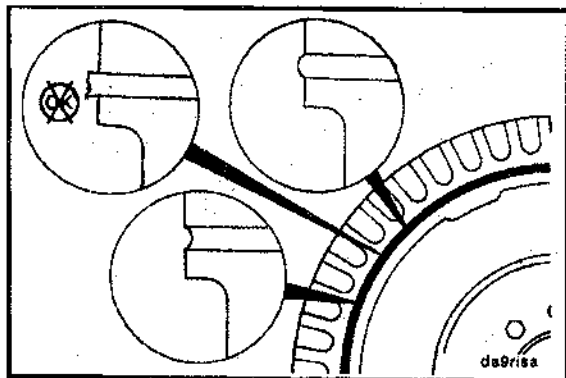

Maintenance procedures at 77,000 Km [48,000Mi.]
B Series



Inspect the rubber member for deterioration. If pieces of rubber are missing or if the elastic member is more than 3.18 mm [1/8 inch] below the metal surface, replace the damper.

NOTE: Also look for forward movement of the damper ring on the hub. Replace the damper if any movement is detected.

Section D-System Diagrams

Section Contents

Air System.....	D-10
Air System-Exhaust Air.....	D-12
Air System-Intake Air.....	D-11
Coolant System.....	D-9
Fuel System.....	D-3
General Information.....	D-2
Hydraulic Cold Start Injection Advance(Rotary Automotive Pumps Only).....	D-4
Lubricating Oil System.....	D-5
Lubricating for the Overhead.....	D-8
Lubricating for the Power Components.....	D-7
Lubricating for the Turbocharger.....	D-6

General Information

The following drawings show the flow through the engine systems. Although parts can change between different applications and installation, the flow remains the same. The systems shown are:

- Fuel System
- Lubricating Oil System
- Coolant System
- Intake Air System
- Exhaust System

Knowledge Of the engine systems can help you in troubleshooting, service and general maintenance of your engine.

Fuel System

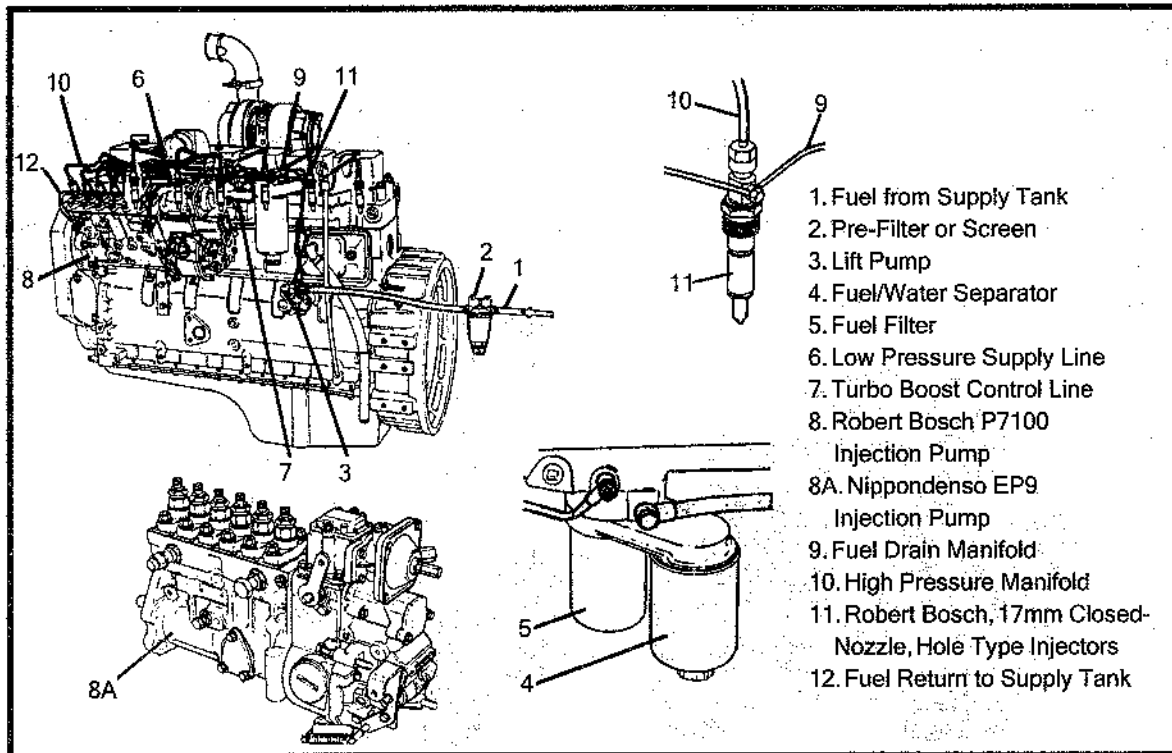

Hydraulic Cold Start Injection Advance (Rotary Automotive Pumps Only)

A hydraulic cold start injection advance (KSB) device is used on 1988 and later certified engines for white smoke control during cold starting.

When the engine is cold, the KSB causes the injection timing mechanism to be fully advanced at low speeds. When the engine reaches normal operating temperature, the KSB is deactivated and injection timing is then advanced proportionally to increased engine speed.

Deactivation of the KSB is controlled by a temperature sensor switch located in the engine air intake manifold. A wiring harness connects the KSB and temperature switch. If the wiring is disconnected, the KSB remains activated and the injection timing is fully advanced.

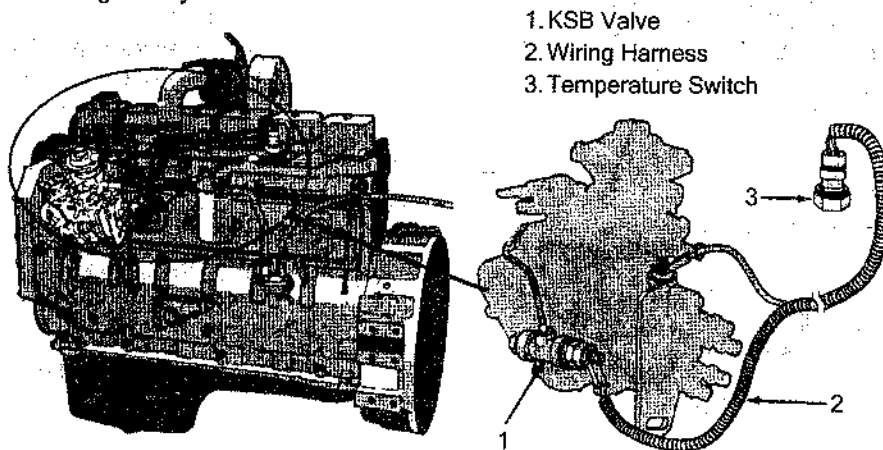

Lubricating Oil System

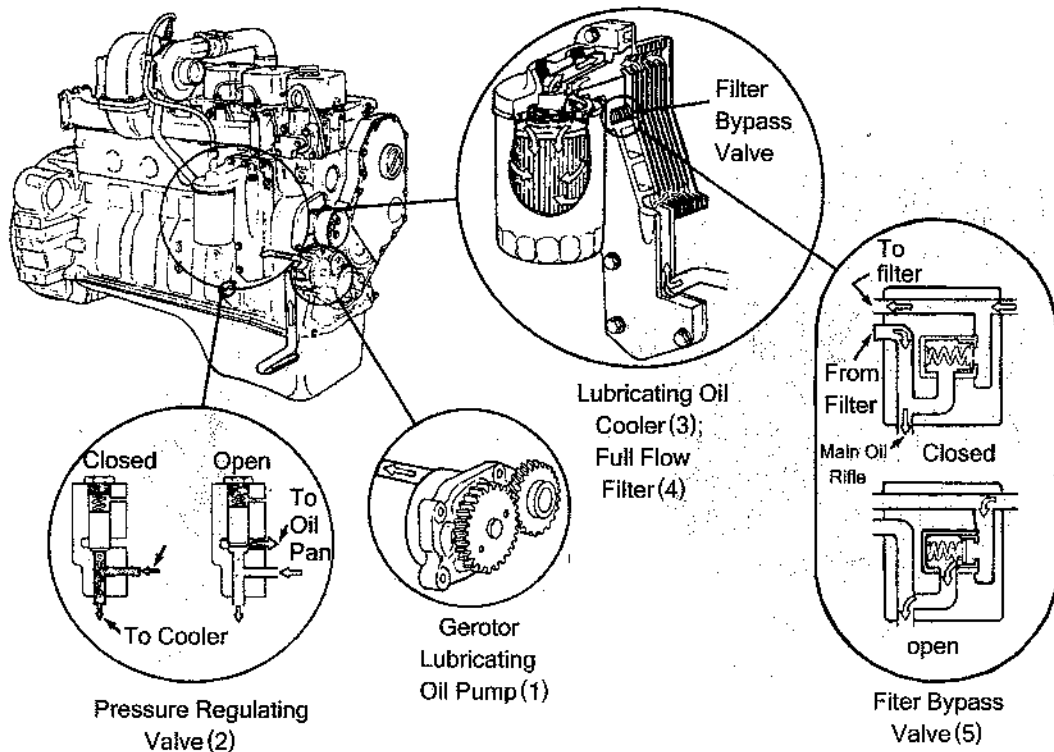

Lubricating for the Turbocharger

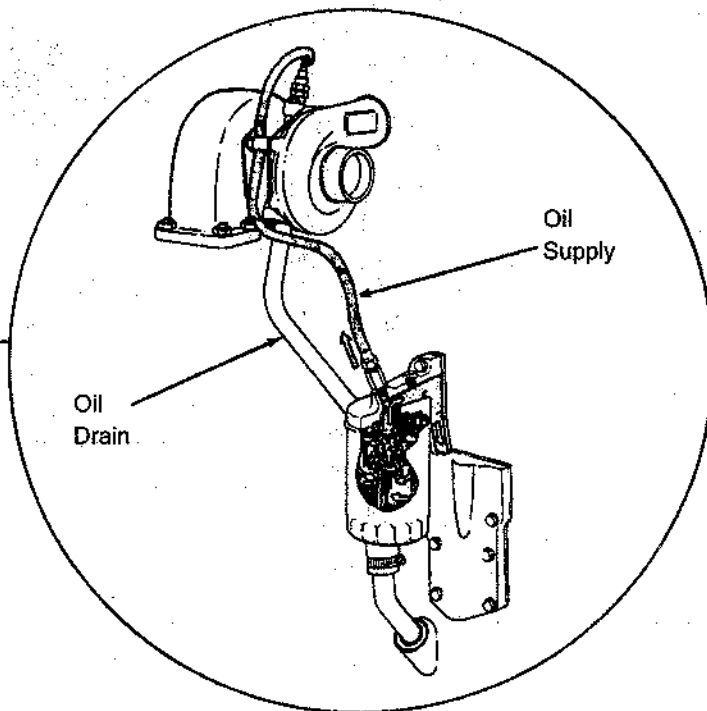
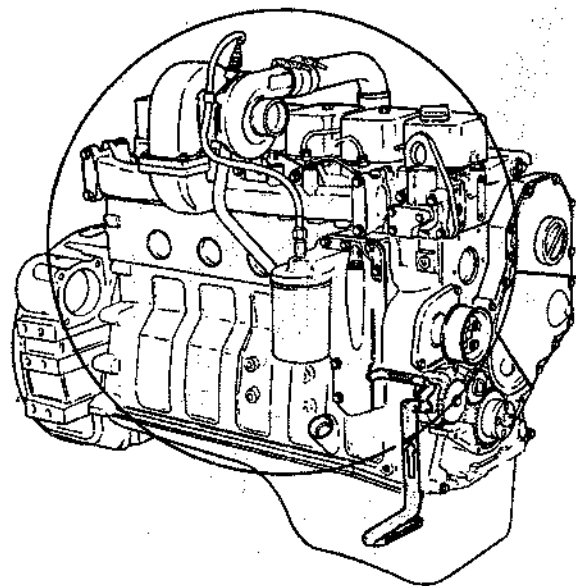

Lubricating for the Power Components

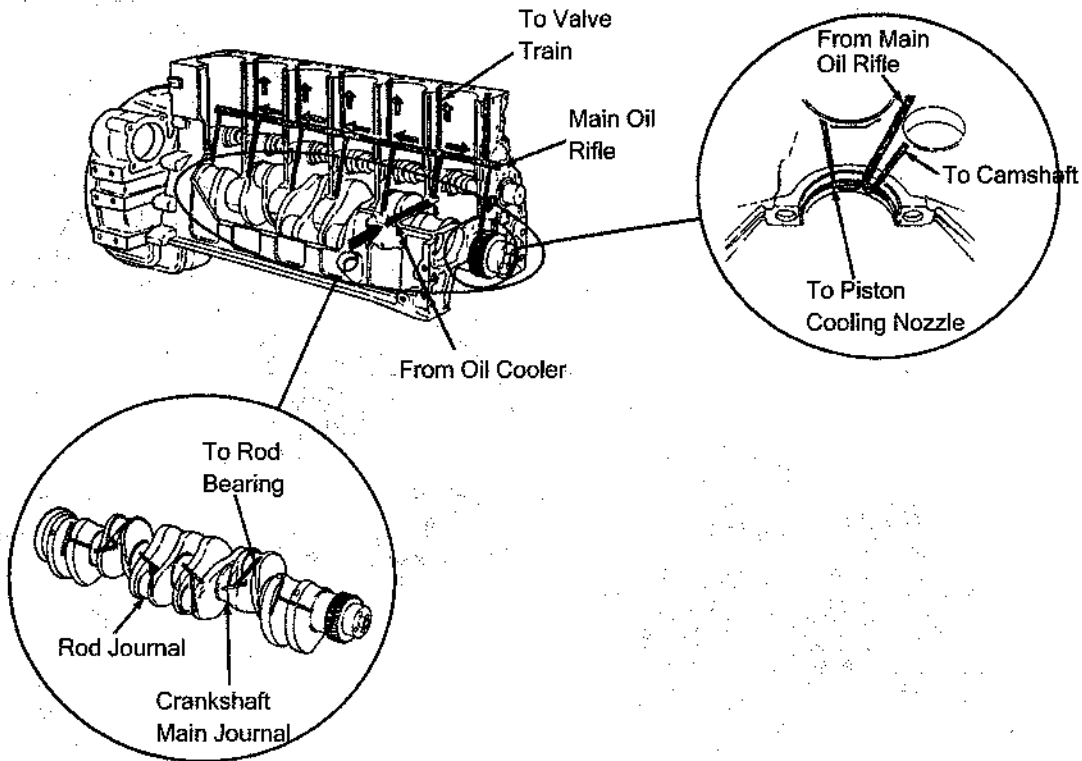

Lubricating for the Overhead

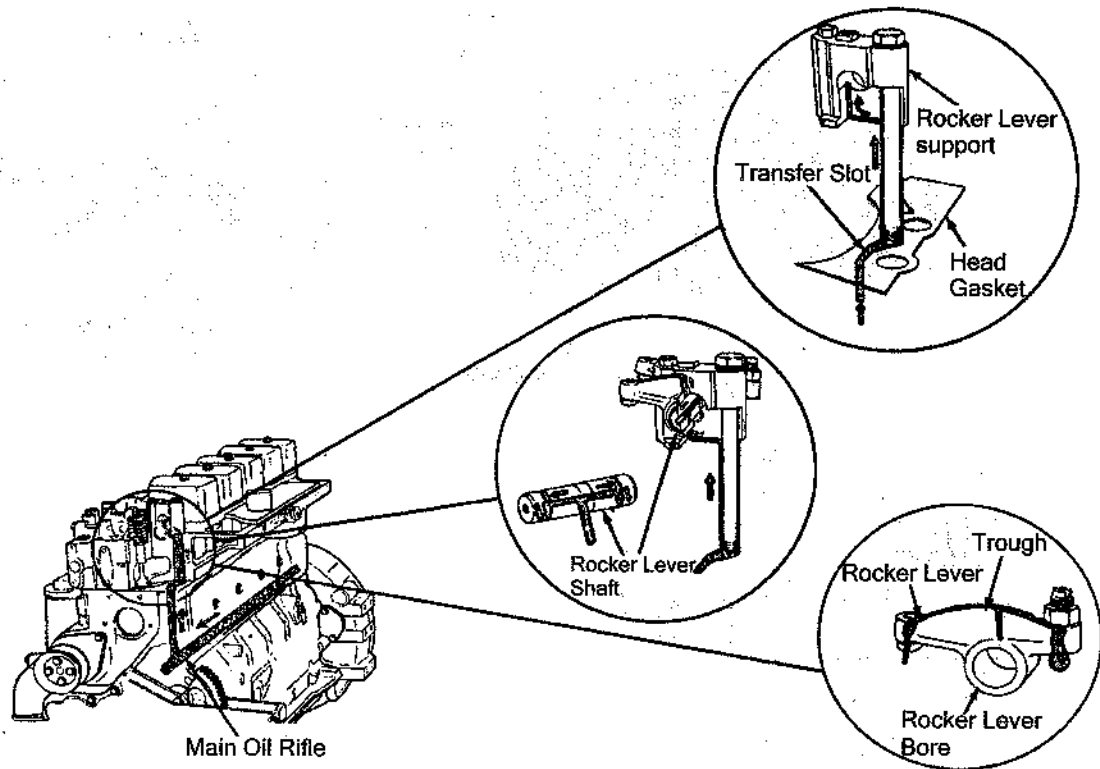

Coolant System

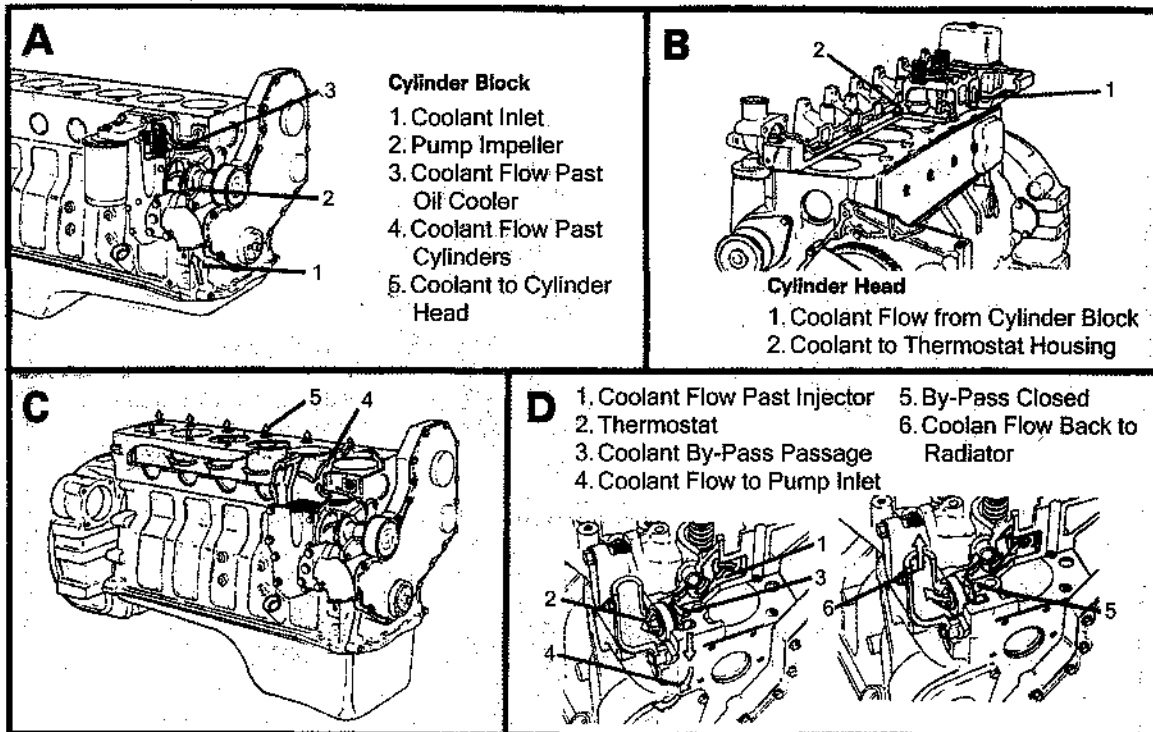

Air System

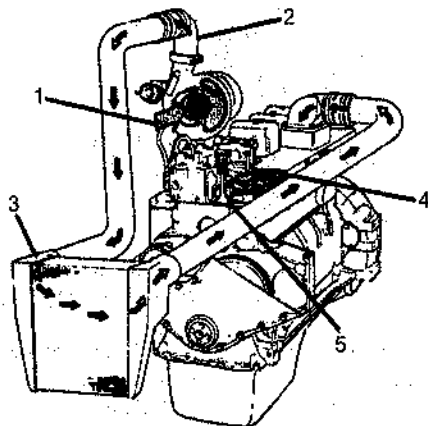

Intake System

1. Intake Air Inlet to Turbocharger.
2. Turbocharger Air to Charge Air Cooler
3. Charge Air Cooler
4. Intake Manifold
(Integral part of Cylinder Head)
5. Intake Valve

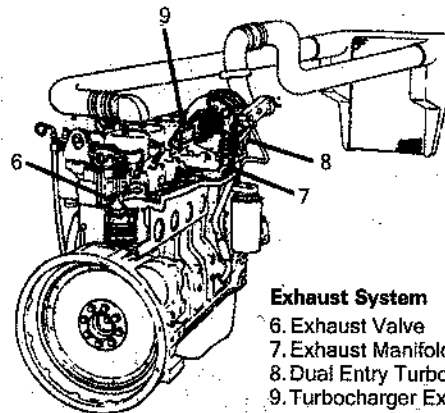

Exhaust System

6. Exhaust Valve
7. Exhaust Manifold (Pulse Type)
8. Dual Entry Turbocharger
9. Turbocharger Exhaust Outlet

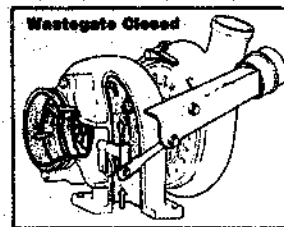
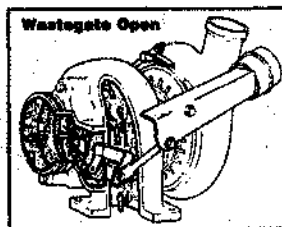

Air System-Intake Air

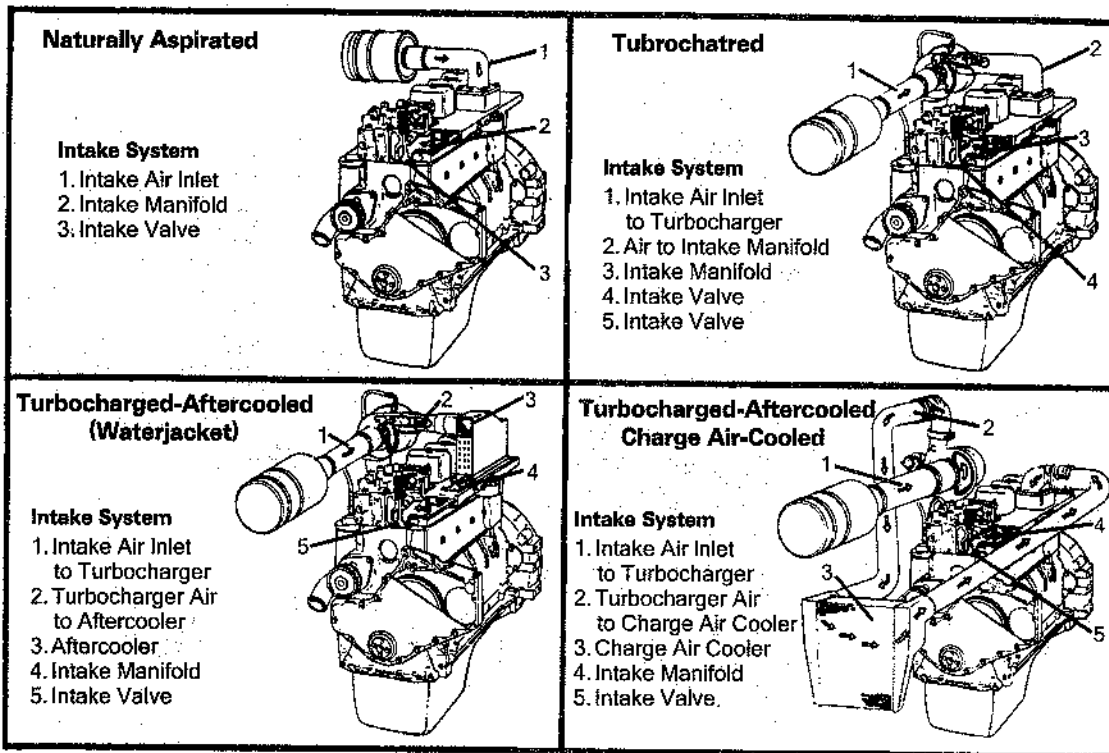

Air System-Exhaust Air

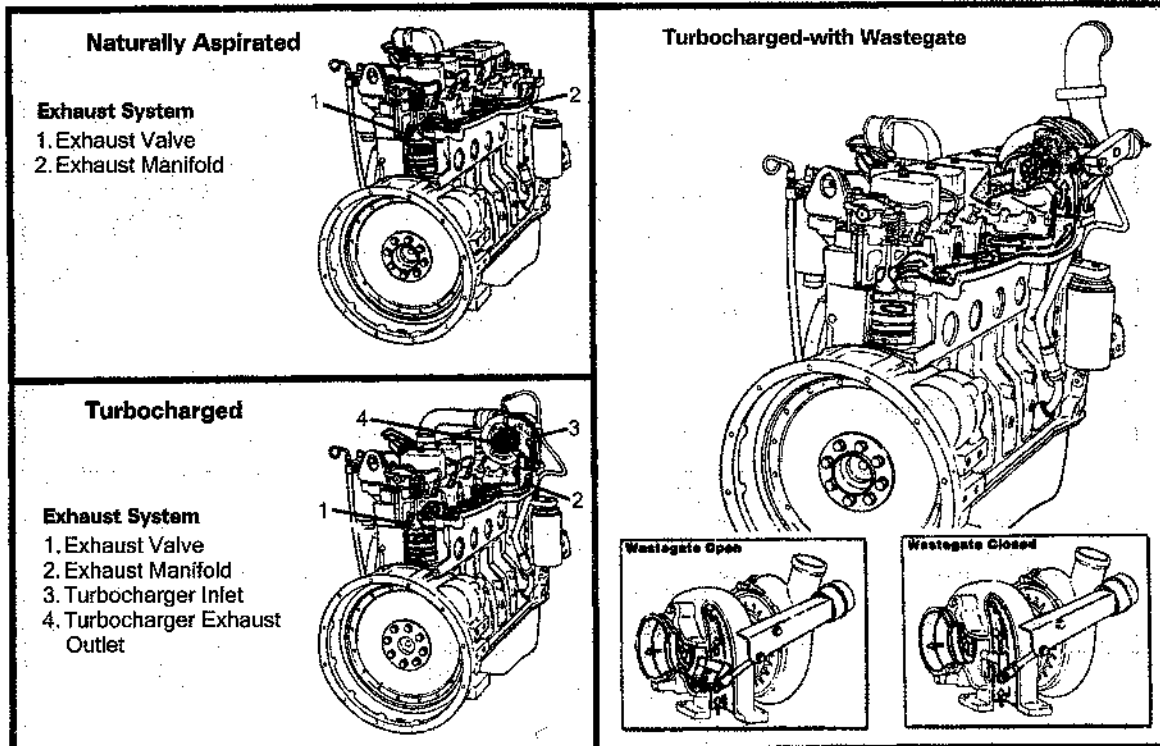

Section T-Troubleshooting

Section Contents

	Page
Troubleshooting Procedures and Techniques.....	T-3
Troubleshooting Symptoms.....	T-3
Alternator Not Charging or Insufficient Charging.....	T-31
Coolant Contaminated.....	T-19
Coolant Loss.....	T-17
Coolant Temperature Above Normal.....	T-15, T-16
Coolant Temperature Below Normal.....	T-18
Engine Cranks But Will Not Start (No Smoke From Exhaust).....	T-6
Engine Hard to Start to Will Not Start(Exhaust Smoke Present).....	T-5
Engine Misfiring.....	T-26
Engine Noises Excessive.....	T-30
Engine Starts But Will Not Keep Running.....	T-7
Engine Surges at Idle.....	T-10
Engine Will Not Crank or Cranks Slowly.....	T-4
Engine Will Not Reach Rated Speed When Loaded.....	T-23
Engine Will Not Shut Off.....	T-8
Exhaust Smoke Excessive Under Load.....	T-22
Fuel Consumption Excessive.....	T-28
Fuel Knock.....	T-27
Fuel or Oil Leaking from Exhaust Manifold.....	T-21
Lubricating Oil Contaminated.....	T-20
Lubricating Oil Loss.....	T-14
Lubricating Oil Pressure Low.....	T-11, T-12
Lubricating Oil Pressure Too High.....	T-13
Power OutPut Low.....	T-24, T-25
Rough Idle, Warm Engine.....	T-9

Vibration Excessive.....	T-29
White Smoke Excessive During Cold Start.....	T-32

Troubleshooting Procedures and Techniques

This guide describes some typical engine operating problems, their causes, and some acceptable corrections to those problems. Unless noted otherwise, the problems listed are those which an operator can diagnose and repair. See a Cummins Authorized Repair Location for diagnosis and repair of problems **not** listed.

Follow the suggestions below to develop good troubleshooting procedures:

- Study the problem thoroughly before acting.
- Do the easiest and obvious things first.
- Find and correct the basic cause of the problem.

Troubleshooting Symptoms

Use the charts given on the following pages to help find the cause and correction of a malfunction. Read each row of blocks from top to bottom. Follow the arrows through the chart to identify corrective action.

Engine Will Not Crank or Cranks Slowly

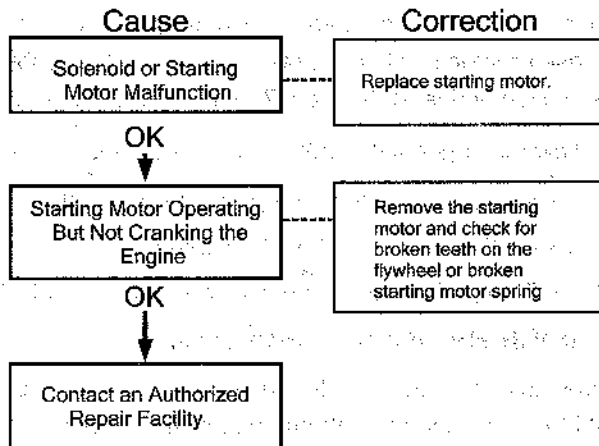
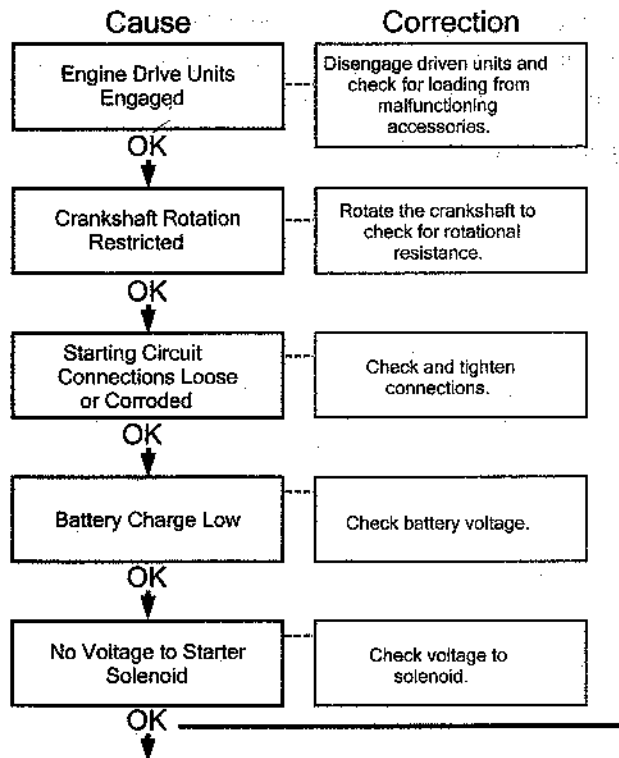

Engine Hard to Start or Will Not Start (Exhaust Smoke Present)

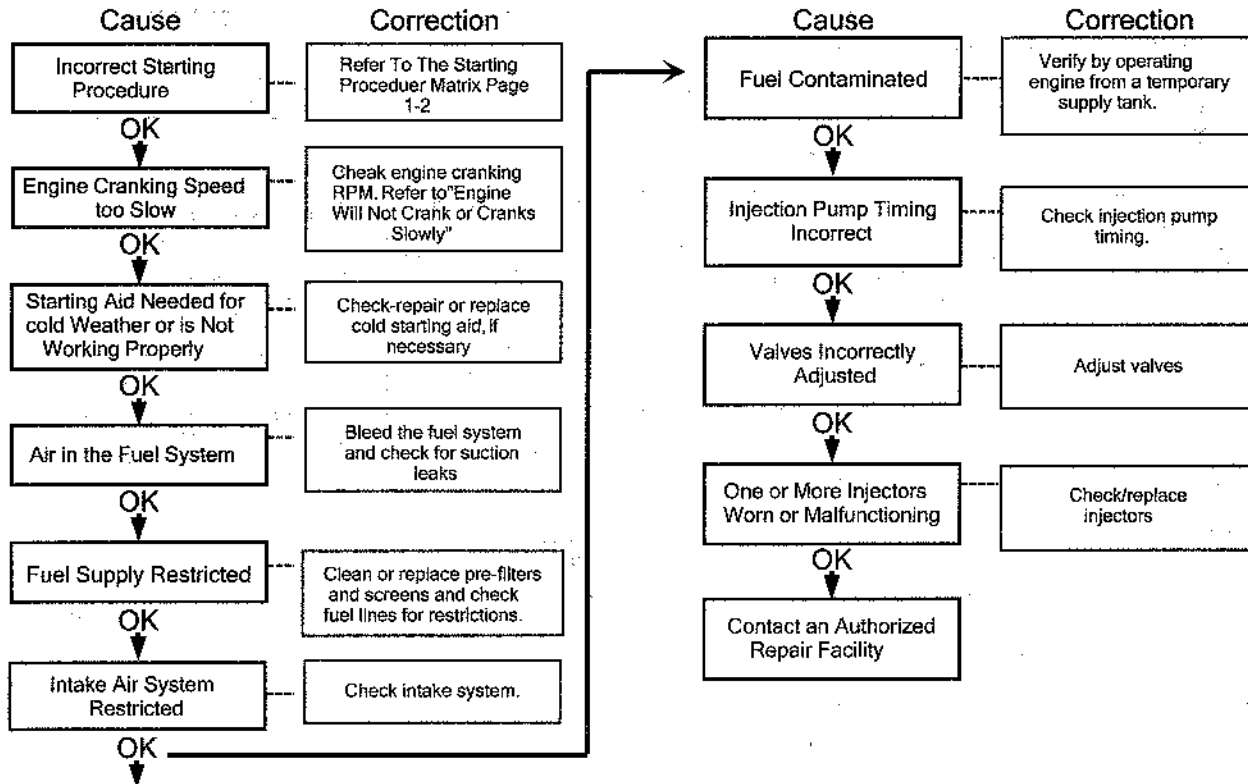

Engine Cranks But Will Not Start (No Smoke From Exhaust)

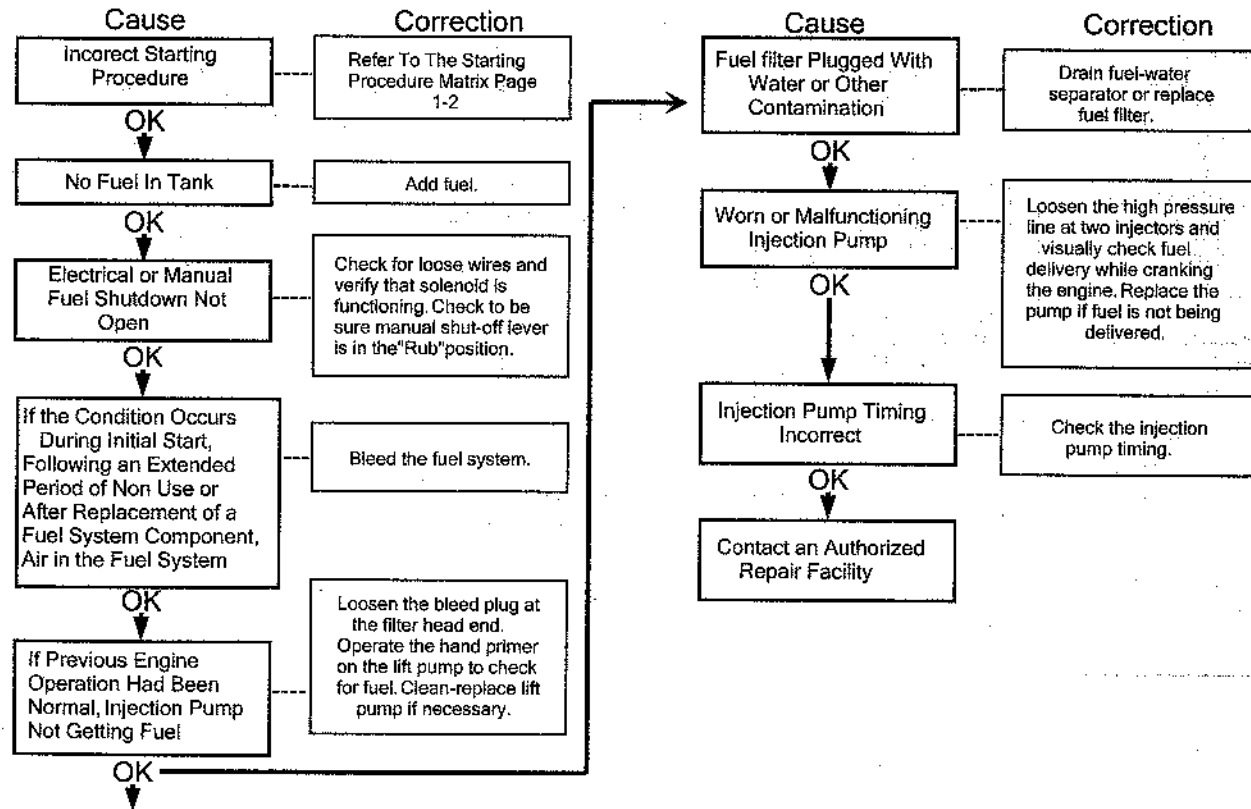

Engine Will Not Shut Off

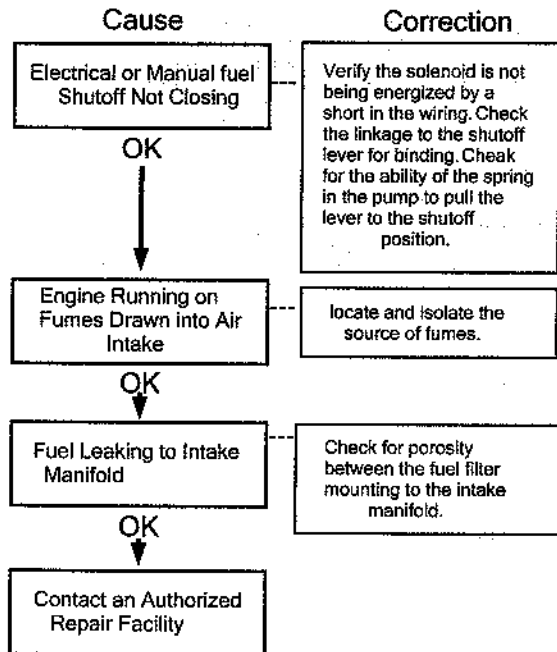

Rough Idle, Warm Engine

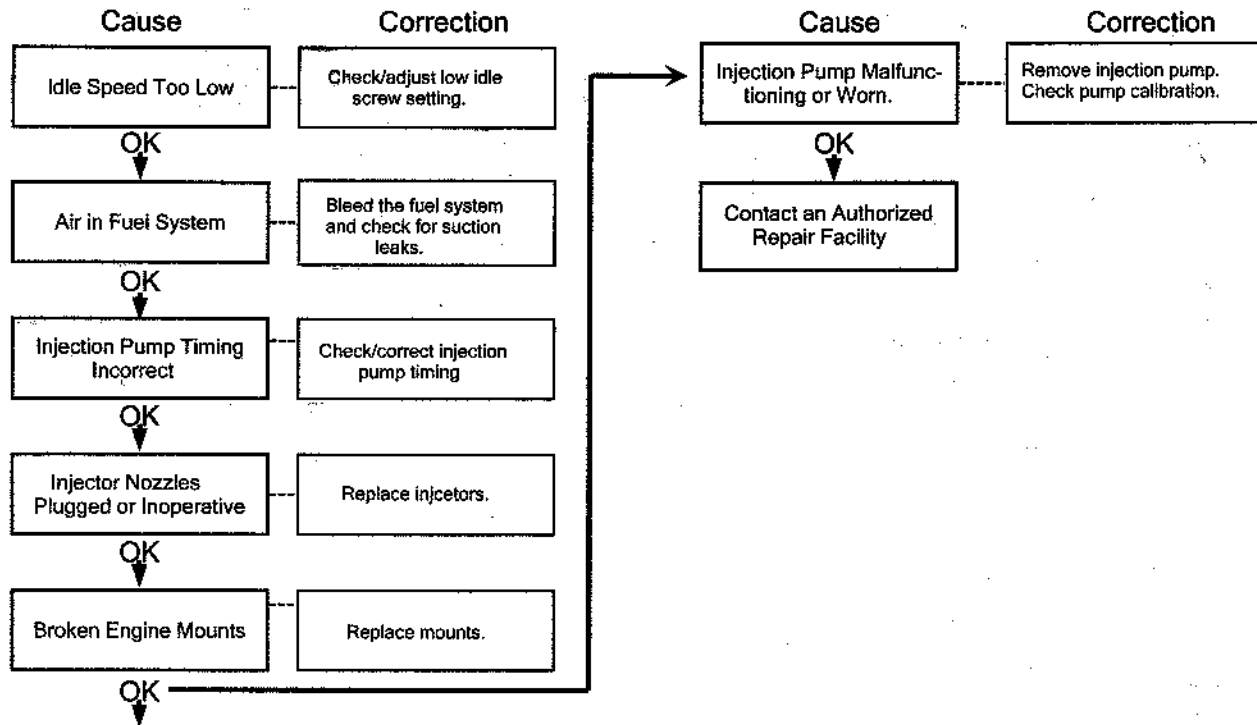

Engine Surges at Idle

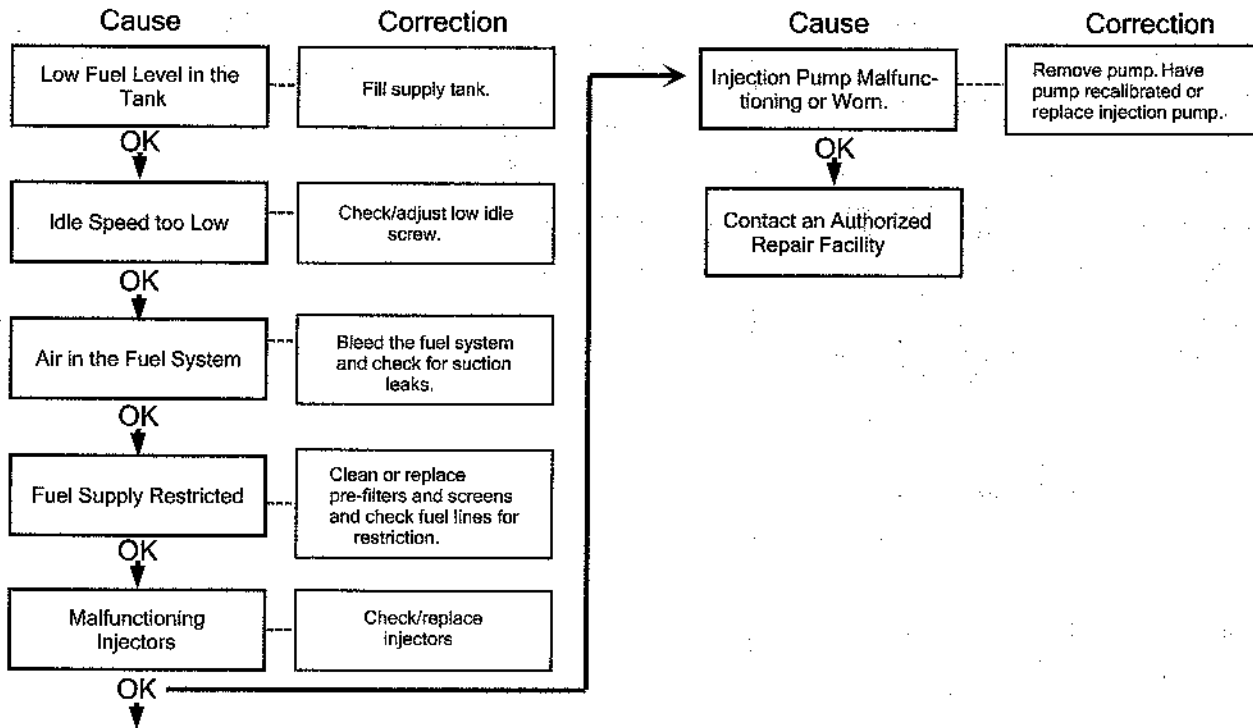

Lubricating Oil Pressure Low

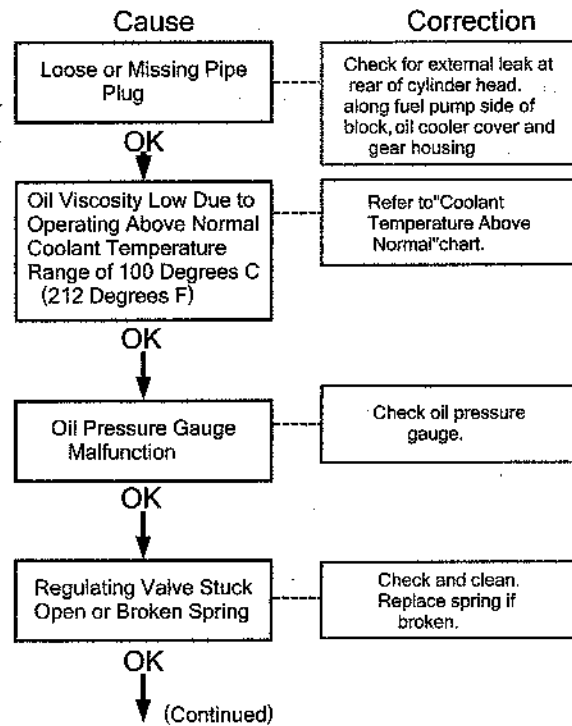
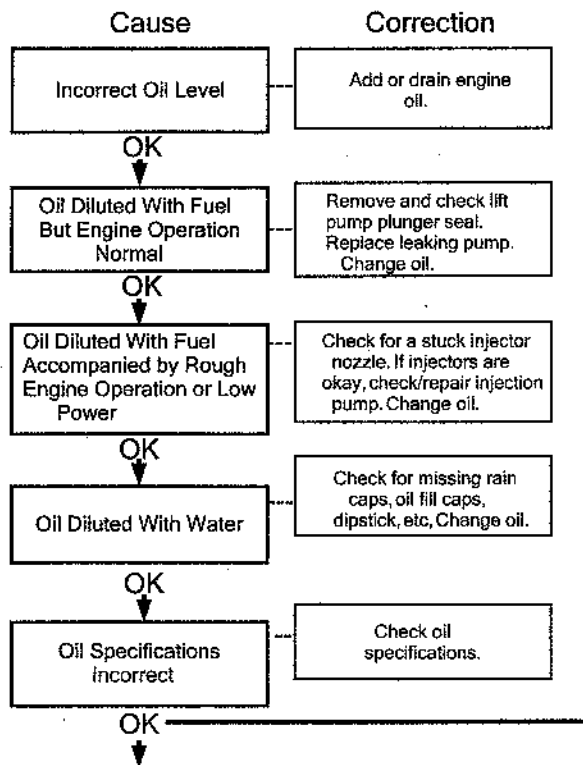

Lubricating Oil Pressure Low (Continued)

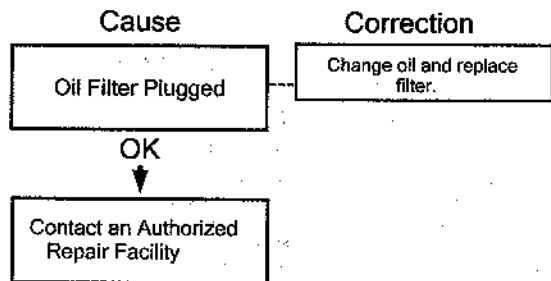

Lubricating Oil Pressure Too High

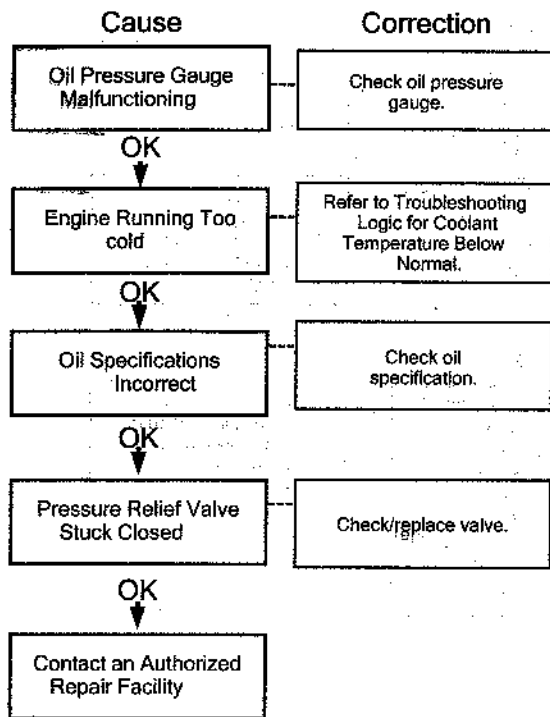

Lubricating Oil Loss

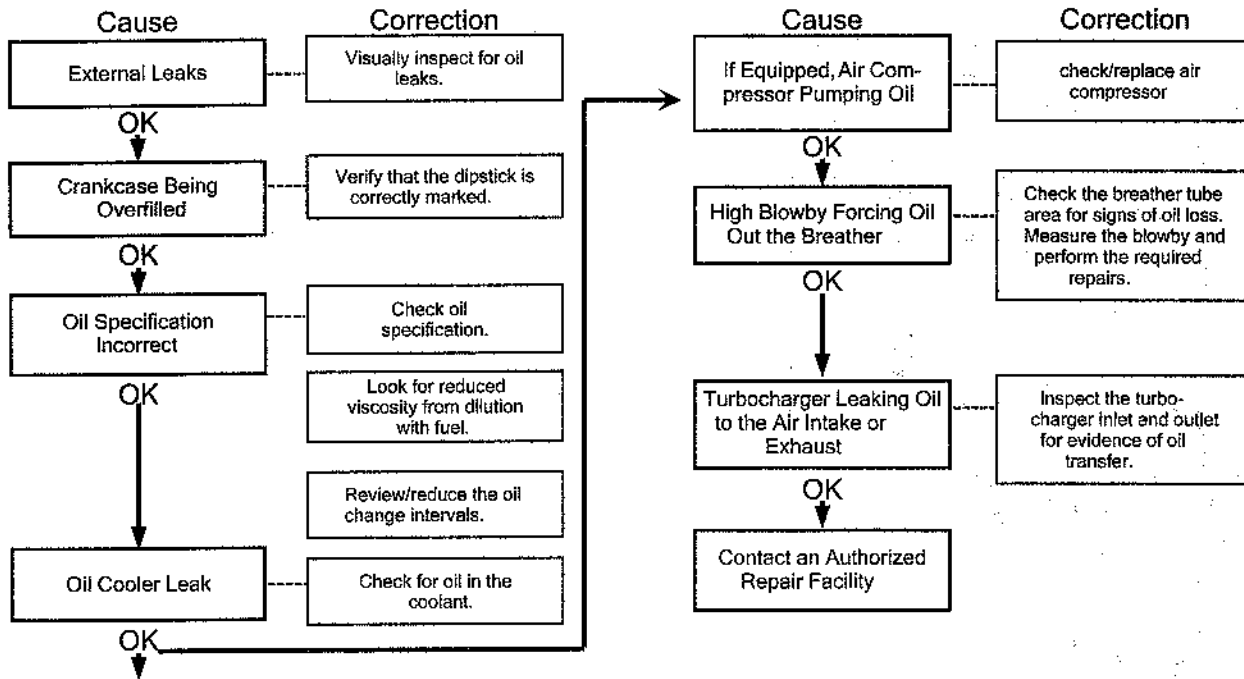

Coolant Temperature Above Normal

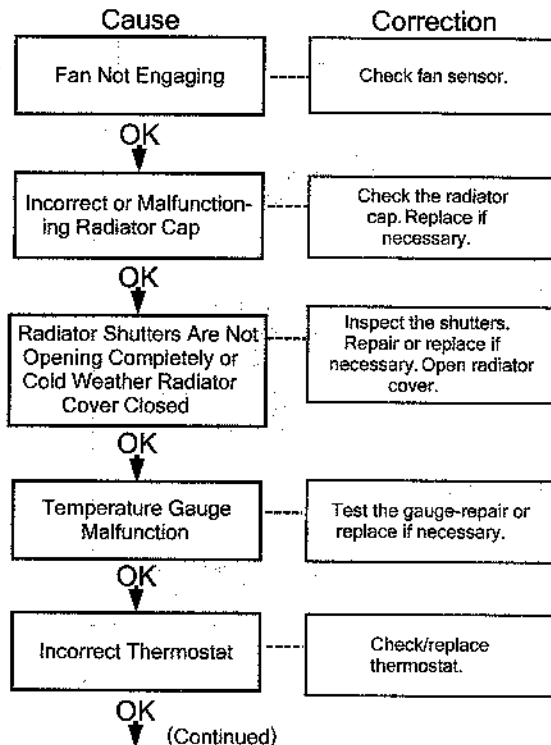
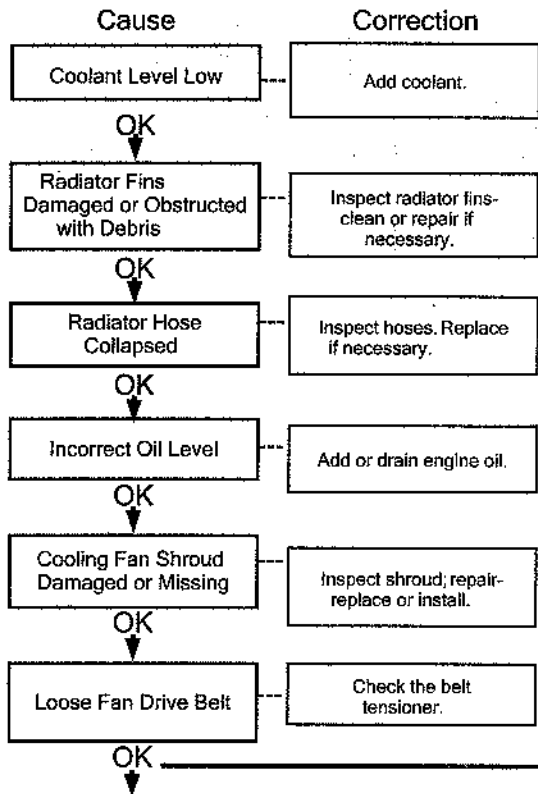

Coolant Temperature Above Normal (Continued)

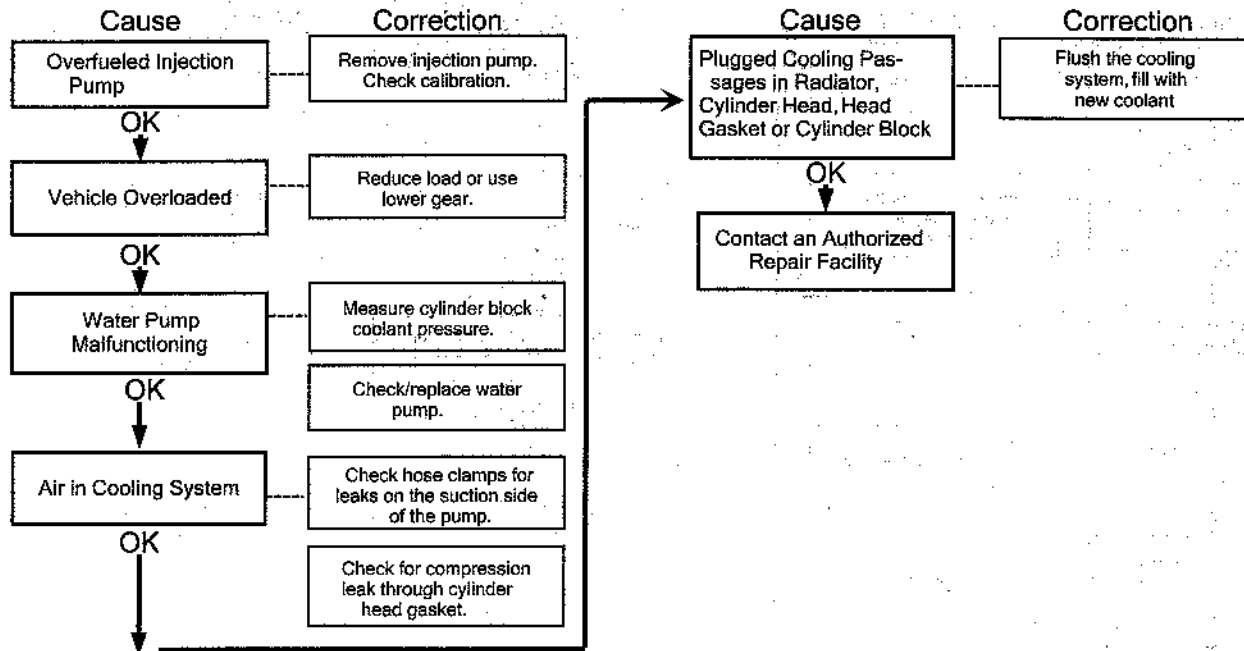

**Troubleshooting
B Series**

Coolant Loss

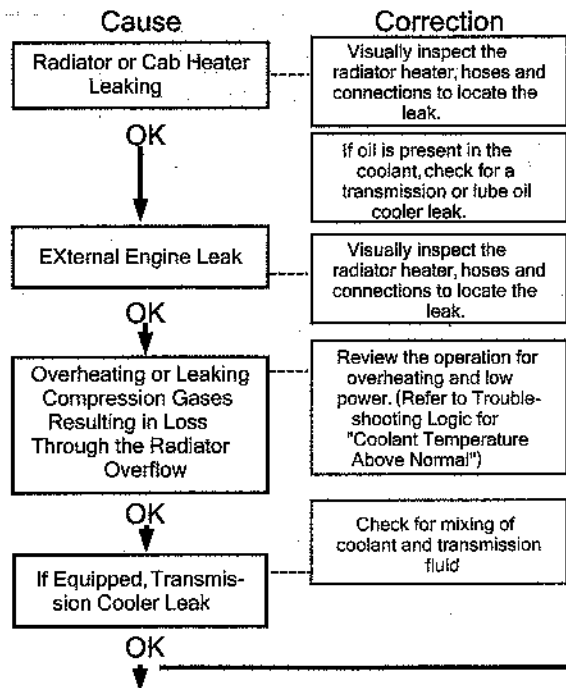

**Troubleshooting Symptoms
Page T-17**

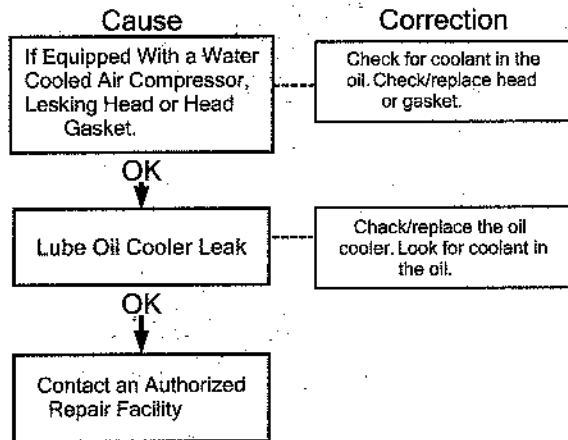

Coolant Temperature Below Normal

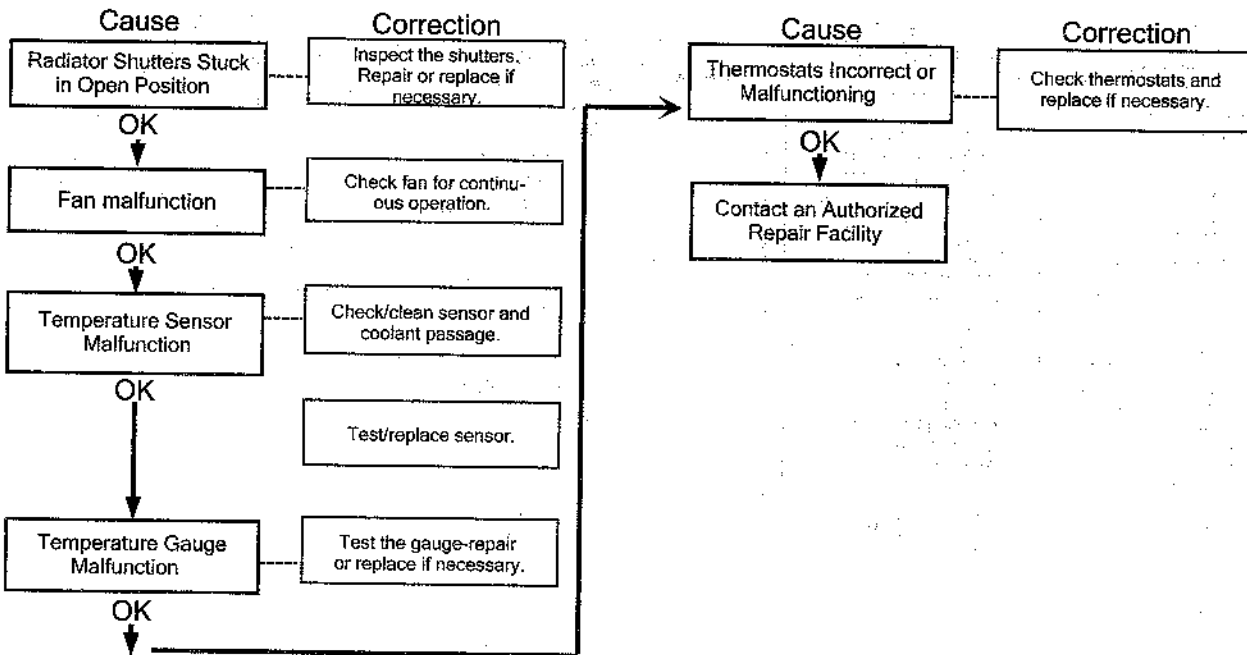

Coolant Contaminated

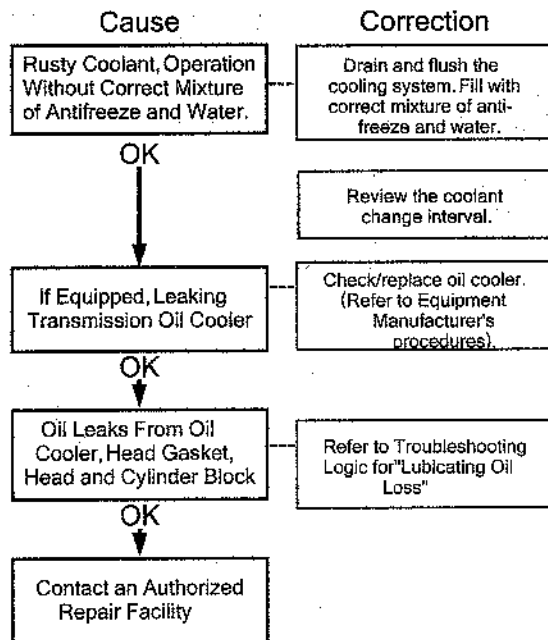

Lubricating Oil Contaminated

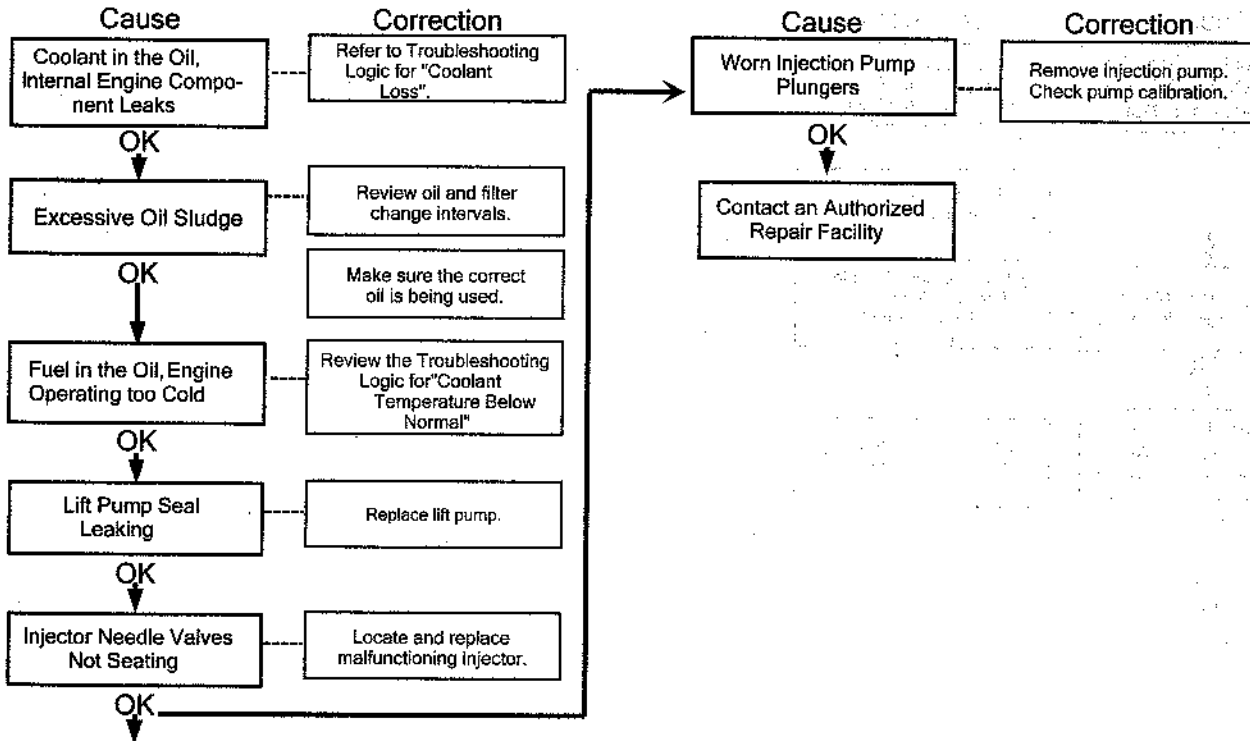

Fuel or Oil Leaking from Exhaust Manifold

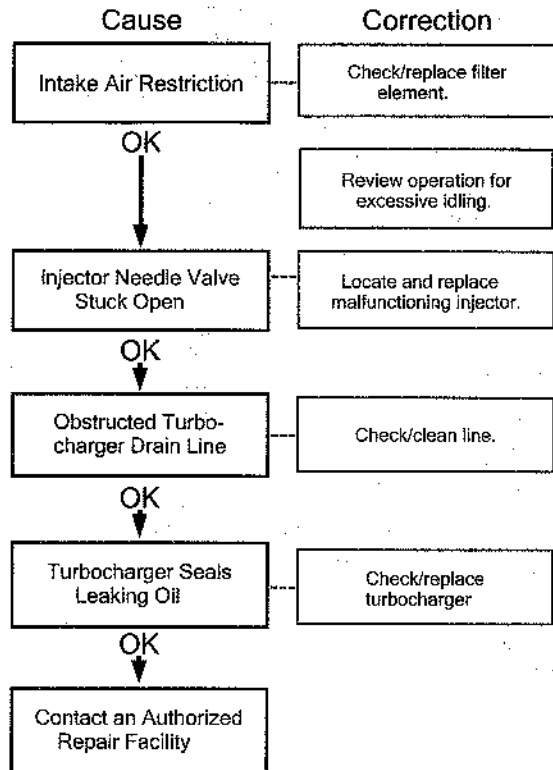

Exhaust Smoke Excessive Under Load

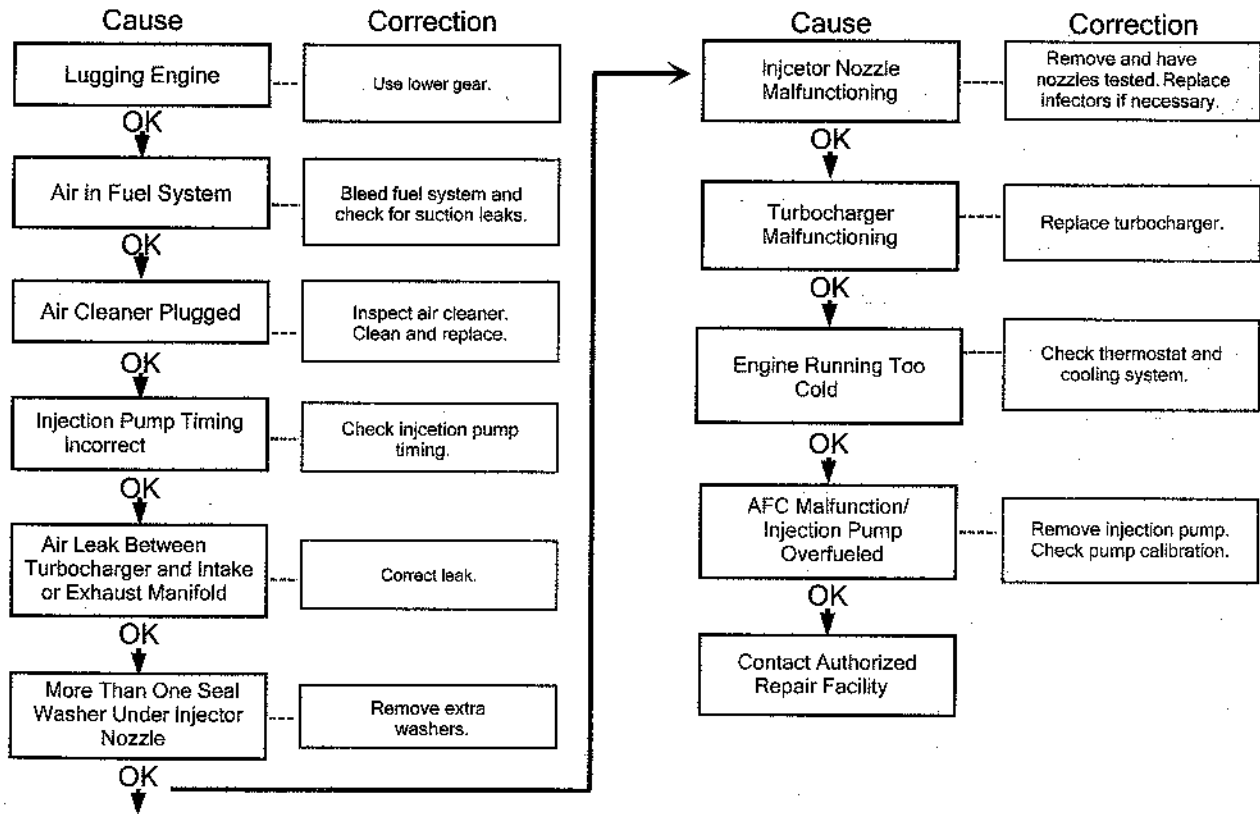

Engine Will Not Reach Rated Speed When Loaded

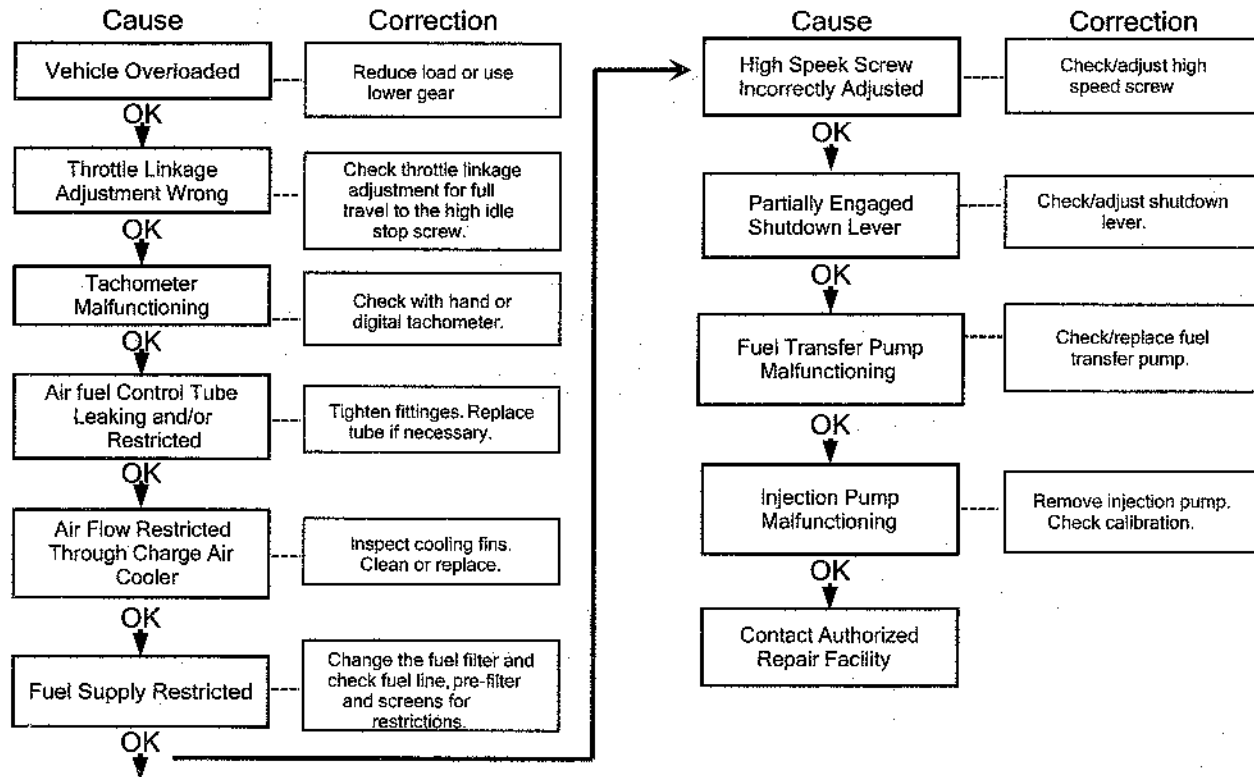

Power Output Low

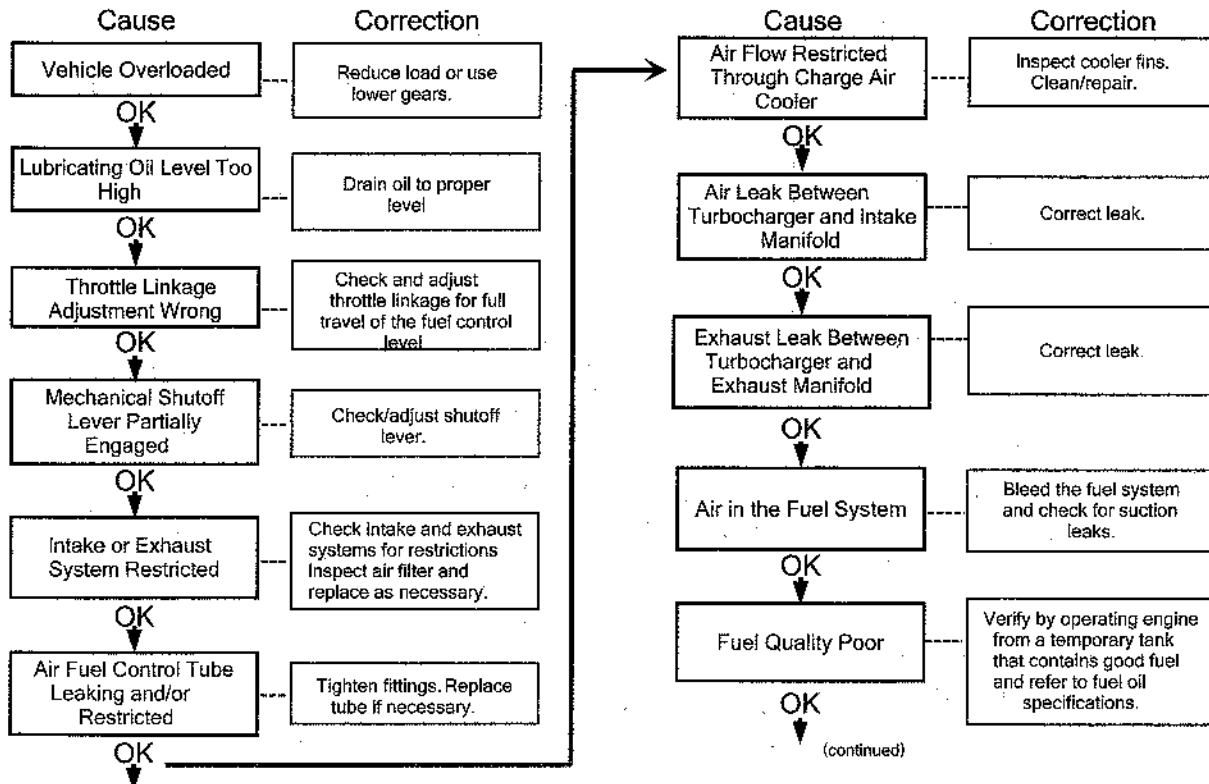

Power Output Low (Continued)

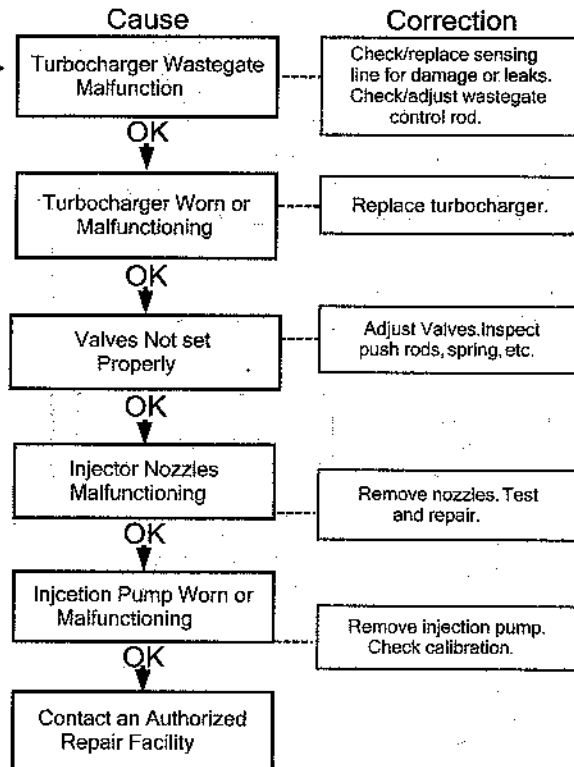
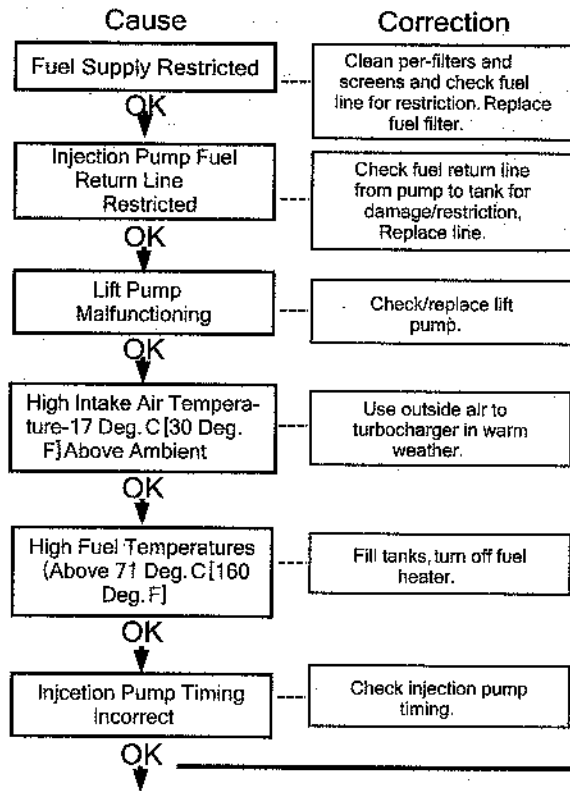

Engine Misfiring

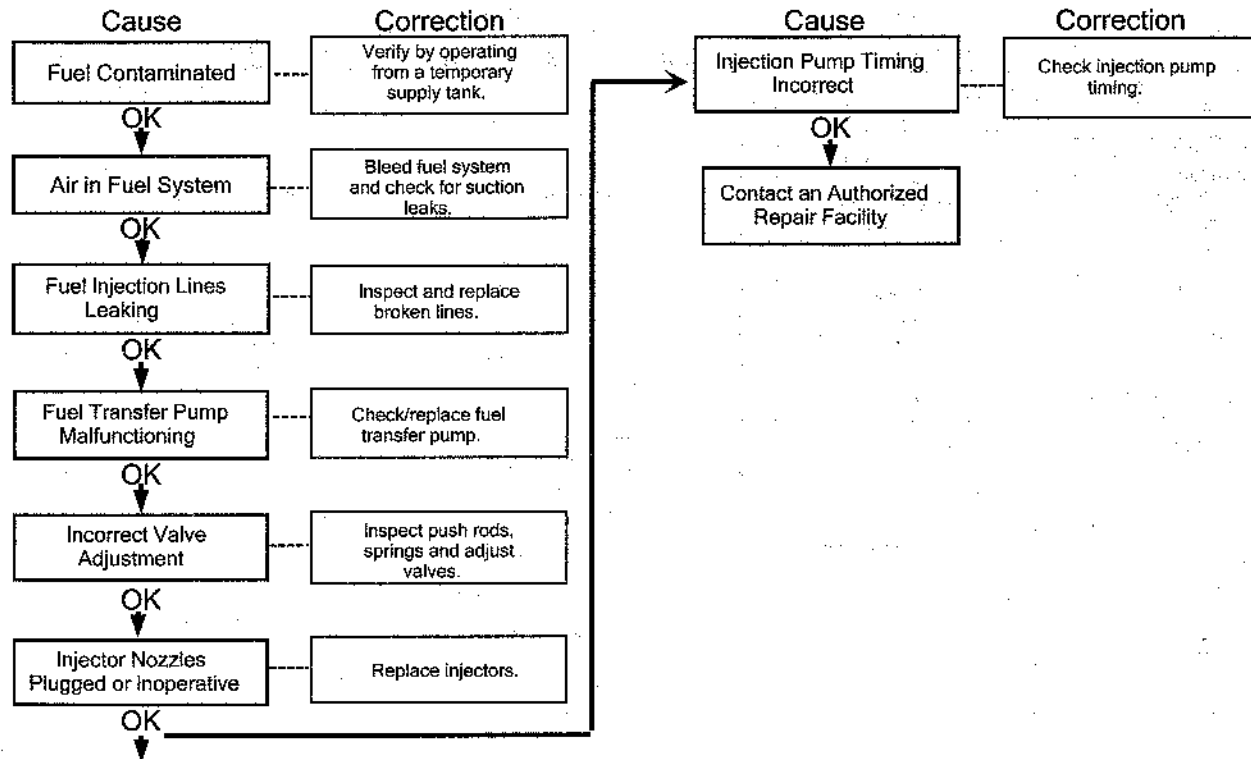

Fuel Knock

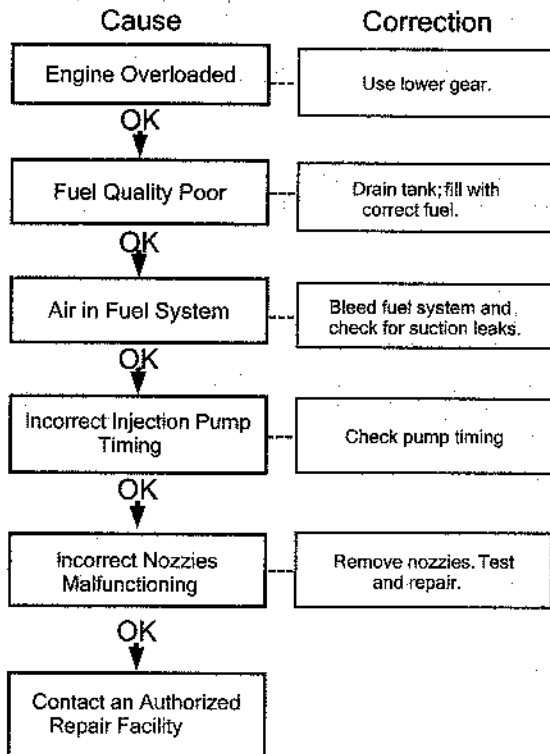

Fuel Consumption Excessive

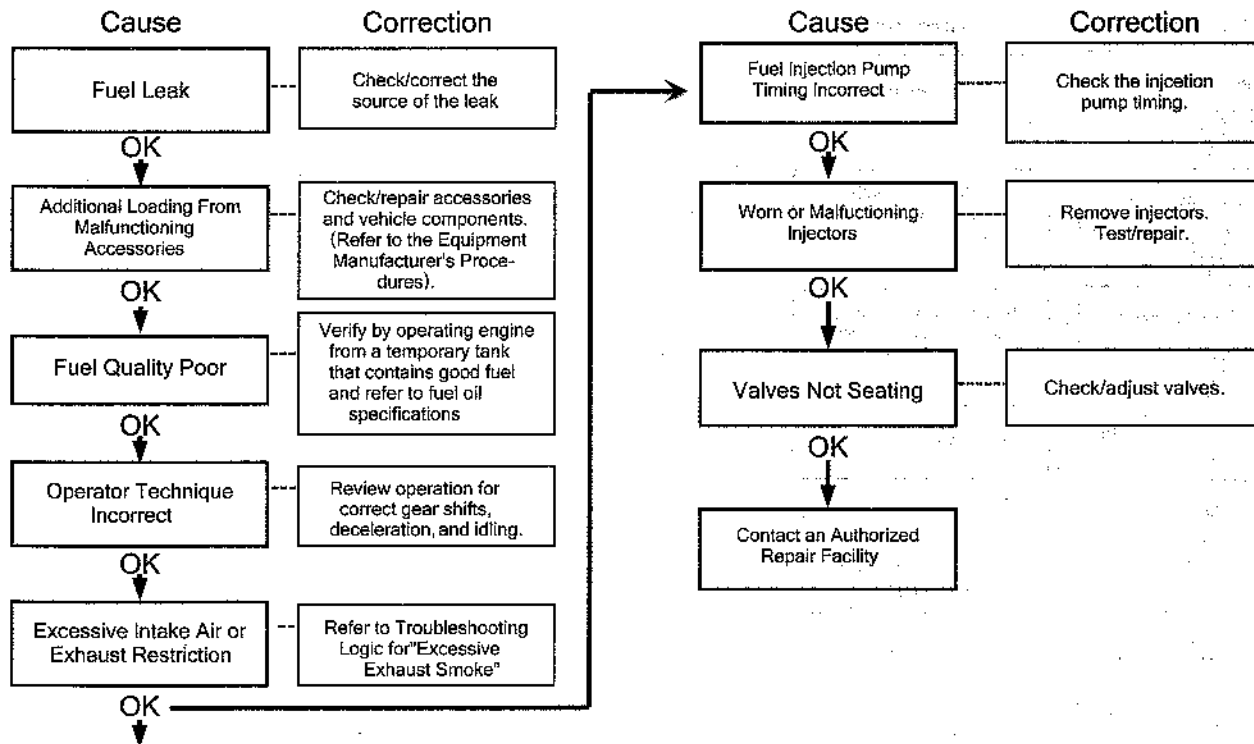

Vibration Excessive

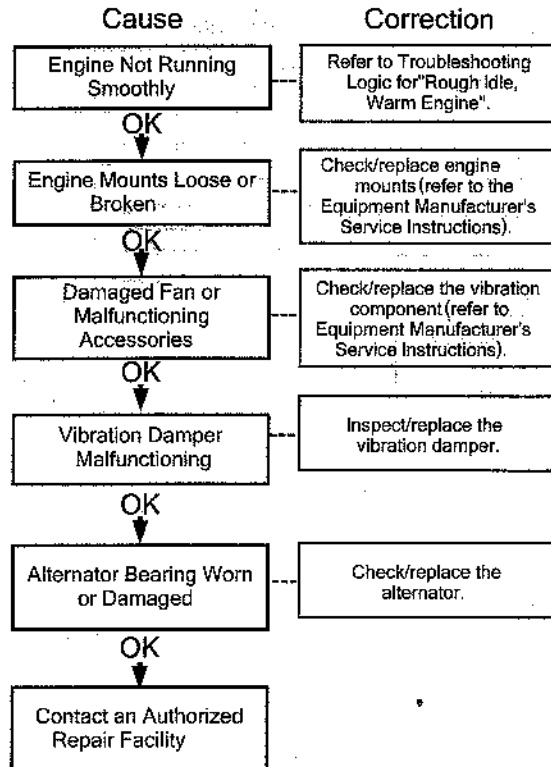

Engine Noises Excessive

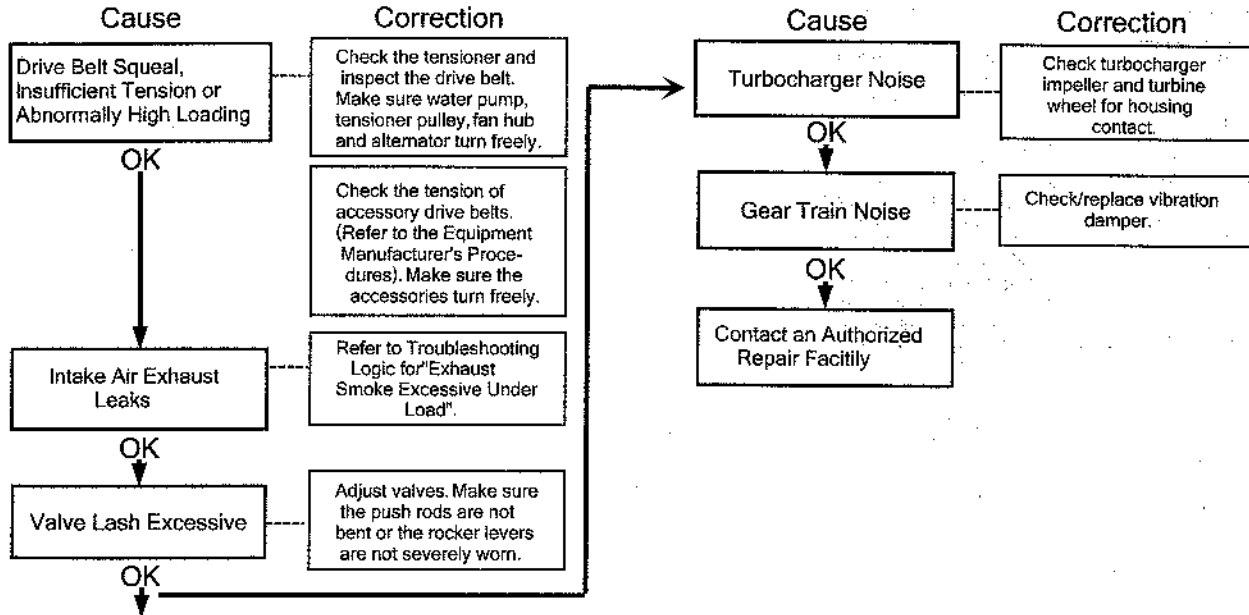

Alternator Not Charging or Insufficient Charging

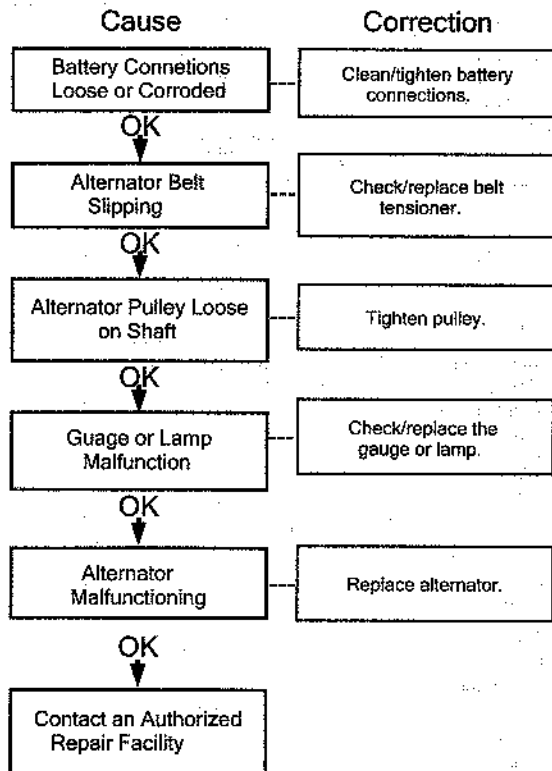

White Smoke Excessive During Cold Start

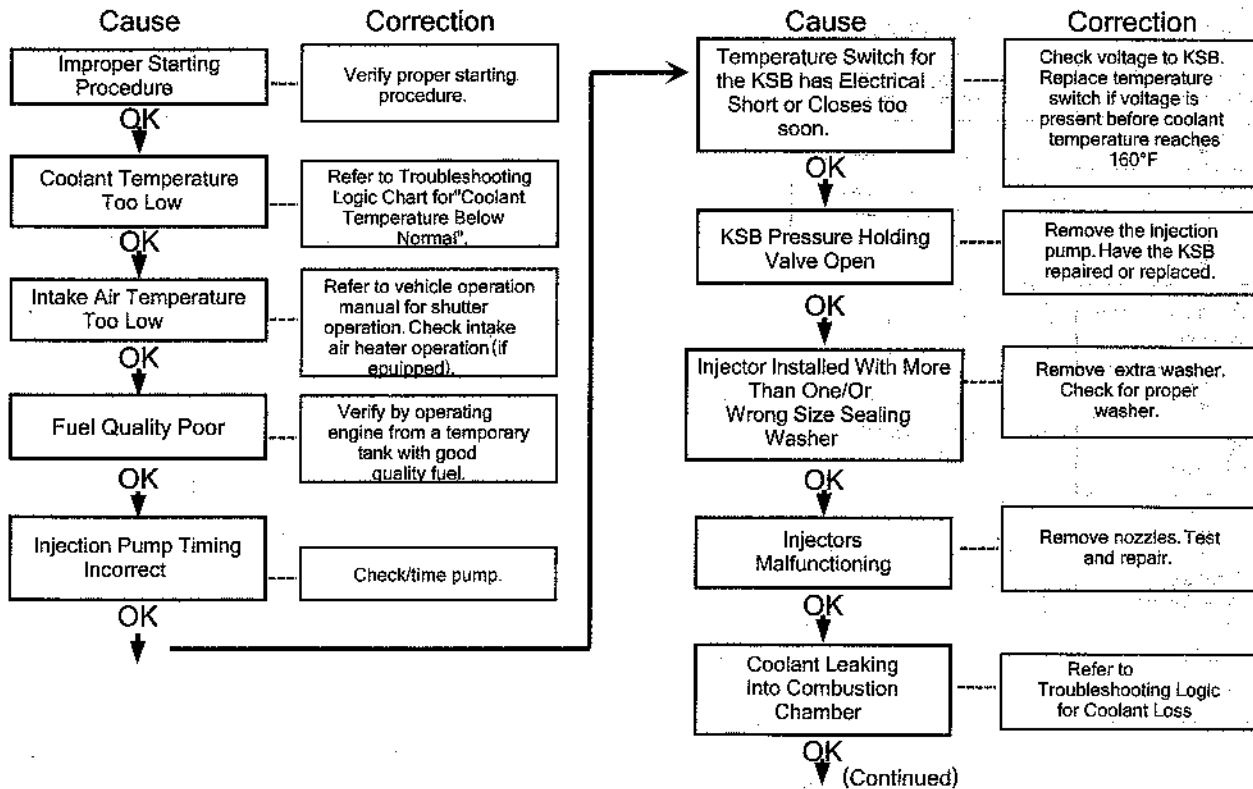

White Smoke Excessive During Cold Start (Continued)

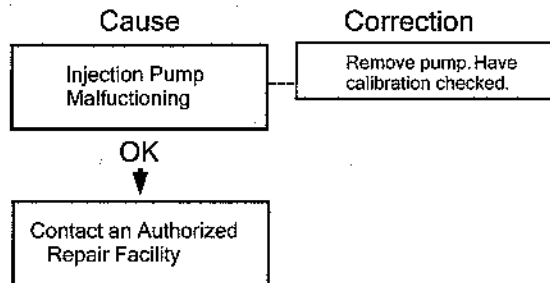



Section A-Adjustment, Replacement and Repair

Section Contents

	Page
Air System Repair	A-82
Air Crossover Tube-Replacement.....	A-82
Charge Air Cooler-Leak Check.....	A-90
Exhaust Manifold and Gaskets-Replacement.....	A-103
Intake Manifold Cover and Gaskets-Replacement.....	A-83
Jacket-Water Aftercooler and Gasket-Replacement.....	A-86
Turbocharger-Replacement.....	A-83
Air System Repair Summary	A-81
Cooling System Repair	A-6
Belt Tensioner-Replacement.....	A-7
Drive Belt-Replacement.....	A-6
Fan Pulley-Replacement.....	A-8
Thermostat-Replacement.....	A-14
Water Pump-Replacement.....	A-9
Cooling System Repair Summary	A-5
Electrical System Repair	A-115
Alternator-Replacement.....	A-116
Starting Motor-Replacement.....	A-115
Electrical System Repair Summary	A-114
Fuel System Repair-In-Line Pump	A-55
Fuel Drain Manifold-Replacement.....	A-62
Fuel Filter Head Adapter-Replacement.....	A-57
Fuel Shutoff Solenoid-Replacement.....	A-68

**Section A-Adjustment, Replacement and Repair
B Series**

Page A-2

	Page
Fuel System Components-Cleaning.....	A-55
High Pressure Fuel Lines-Replacement.....	A-60
Injection Pump-Installation.....	A-73
Injection Pump-Removal.....	A-70
Injection Pump-Replacement.....	A-69
Injection-Replacement.....	A-64
Lift Pump-Replacement.....	A-58
Low Pressure Fuel Line-Replacement.....	A-56
RQVK Governor Shutoff Solenoid.....	A-68
Fuel System Repair-Rotary Pump.....	A-21
Fuel Drain Manifold-Replacement.....	A-28
Fuel Filter Head Adapter-Replacement.....	A-23
Fuel Pump-Replacement.....	A-41
Fuel Shut Off Solenoid-Replacement.....	A-38
Fuel System Components-Cleaning.....	A-21
High Pressure Fuel Lines-Replacement.....	A-26
Injection Pump Supply Line-Replacement.....	A-30
Injectors-Replacement.....	A-32
KSB Replacement.....	A-40
KSB Temperature Switch Replacement.....	A-41
Lift Pump-Replacement.....	A-24
Low Pressure Fuel Lines-Replacement.....	A-21
Fuel System Repair Summary.....	A-20
Injection Pump-Idle Speed Adjustment.....	A-80
RQVK Governor.....	A-80
Lubricating System Repair.....	A-107
Oil Cooler Element and Gasket-Replacement.....	A-108
Oil Pressure Regulator, Valve and Spring-Replacement.....	A-107

**Section A-Adjustment, Replacement and Repair
B Series**

Page A-3

Page

Lubricating System Repair Summary.....

A-106

Repair Tools Required.....

A-4

Repair Tools Required
Page A-4

Section A-Adjustment, Replacement and Repair
B Series

Repair Tools Required

Sockets

10 mm
12 mm
13 mm
15 mm
17 mm
18 mm
19 mm
22 mm
27 mm

Wrenches

8 mm
10 mm
13 mm
15 mm
17 mm (open end)
19 mm
22 mm
24 mm

Other

Allen Wrench (8 mm)
Breaker Bar (1/2 in. Sq. Drive)
Flat Screwdriver
Ratchet (3/8 in. Sq. Drive)
Ratchet (1/2 in. Sq. Drive)
Filter Wrenches (75-80 mm and 90-95 mm)
Drill Motor (1/4 inch)
Drill Bit (3 mm)
Slide Hammer
Flat Chisel
T-Bar Puller (75mm)
Sheet Metal Screw (#10)
Torque Wrench
Pliers
Engine Barring Gear 3377371

Cooling System Repair Summary

Component To Be Replaced	Tools	Preparatory Steps
Drive Belt	Breaker Bar (3/8 inch Square drive)	
Belt Tensioner	Ratchet (3/8 inch drive) 15mm Socket and Torque Wrench	Remove Drive Belt
	10 mm Socket/Wrench	Remove Drive Belt and Pulley
	10 mm Socket/Wrench	Drain Coolant and Remove Drive Belt
	10 mm, 18 mm and 19 mm Socket/Wrench	Drain Coolant, Remove Drive Belt, Loosen Alternator Link, Remove Alternator Mounting Capscrew, Remove Thermostat Housing

Cooling System Repair

Drive Belt-Replacement



3/8 Inch Square Drive



Lift the tensioner arm and pulley to remove and install the belt.



The belt tensioner winds in the direction that the spring tang is bent over the tensioner body. To loosen the tensioner on the belt, rotate the tensioner to wind the spring tighter.

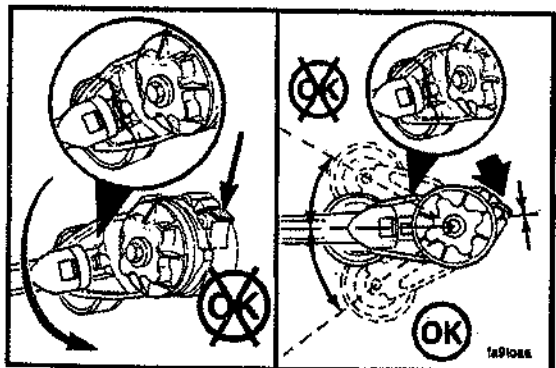
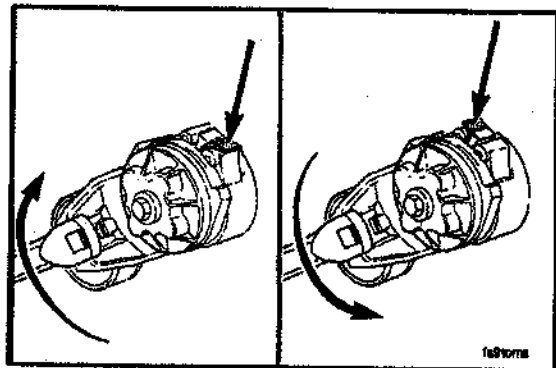

Applying excessive force in the opposite direction of wind-up or after the tensioner has been wound-up to the positive stop can cause the tensioner arm to break.

Section A-Adjustment, Replacement and Repair
B Series

Belt Tensioner-Replacement

Preparatory Step:

- Remove the drive belt.

13 mm

Remove the belt tensioner from the bracket.

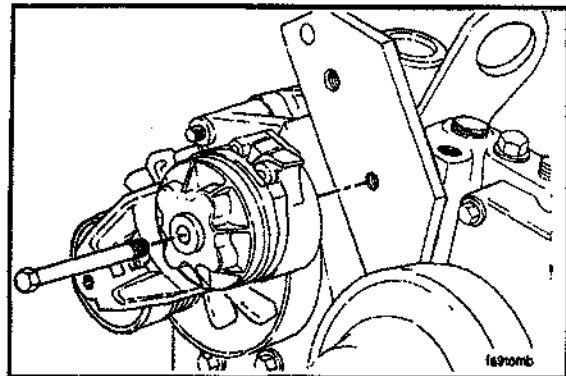

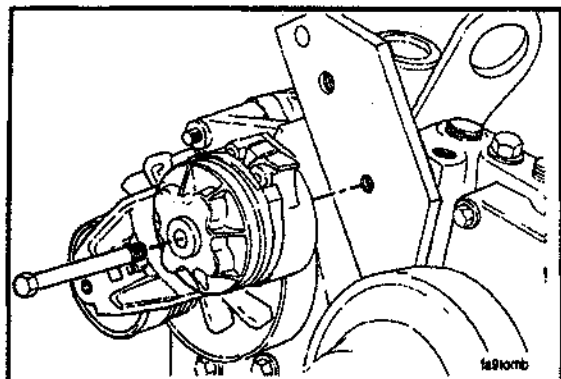

13 mm

Install the belt tensioner.



Torque Value: 43 N•m [32 ft-lb]



Fan Pulley-Replacement

Preparatory Steps:

- Remove the drive belt.

NOTE: Loosen the capscrews before removing the belt and torque the capscrews after the belt is installed.

Section A-Adjustment, Replacement and Repair
B Series

10 mm and 13 mm

Remove the four capscrews, fan and spacer. Replace the fan pulley.

Torque Values:

8 mm Capscrews-24 N•m	[18 ft-lb]
10 mm Capscrews-43 N•m	[32 ft-lb]

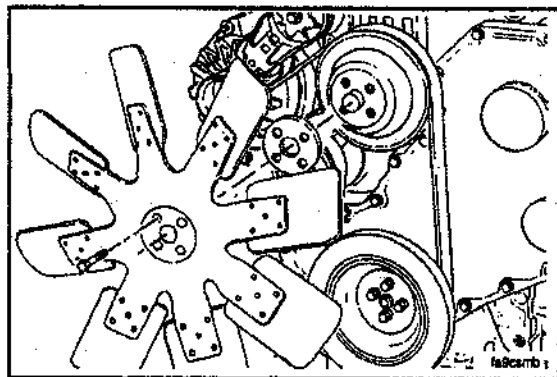

Water Pump-Replacement

Preparatory Steps:

- Drain the coolant.
- Remove the drive belt.

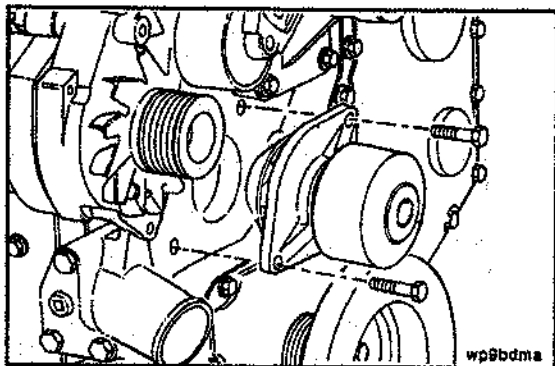

10 mm

Remove the water pump.

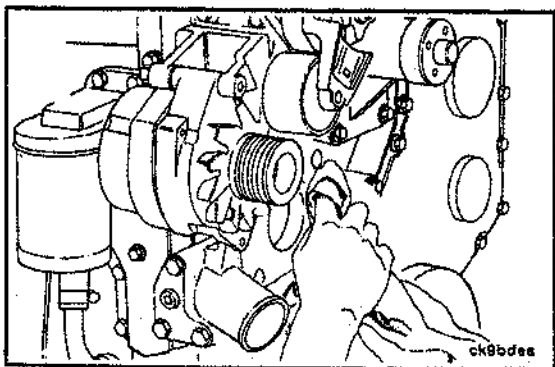

Clean the sealing surface on the cylinder block.

Section A-Adjustment, Replacement and Repair B Series

Install a new o-ring into the groove in the water pump.

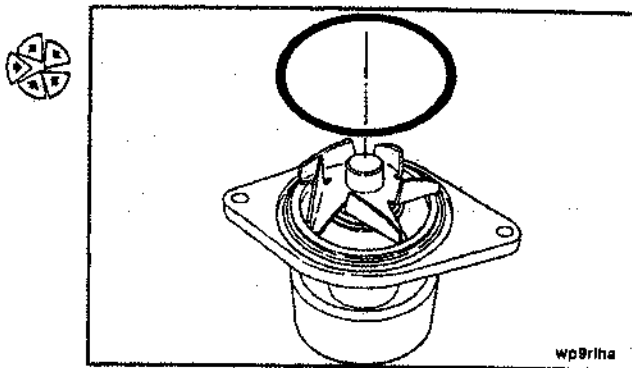

10 mm

Install the water pump.

Torque Value: 24 N·m [18 ft·lb]

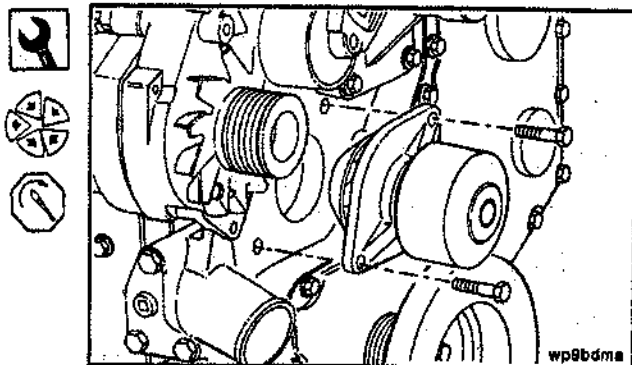

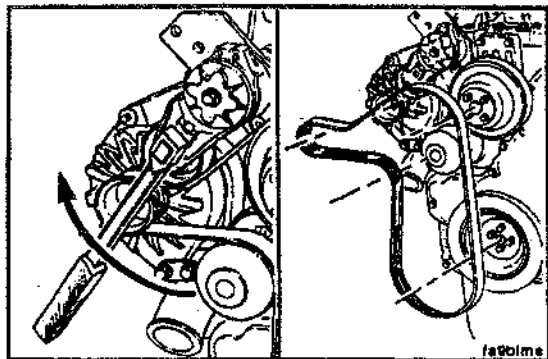

Lift the tensioner arm and pulley to install the drive belt.

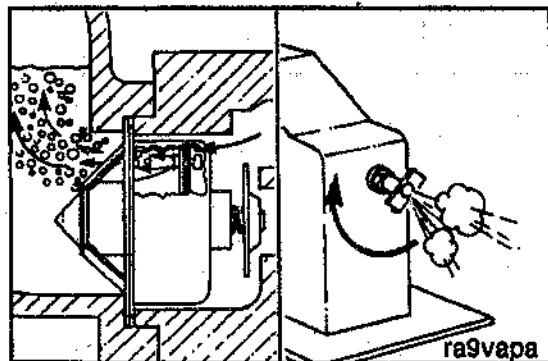

Caution: The system must be filled slowly to prevent air locks. During filling, air must be vented from the engine coolant passages. Be sure to open the petcock on the aftercooler for aftercooled engines.

The system has a maximum fill rate of 14 liters per minute [3.5 U.S. gallons per minute]. Do not exceed this fill rate. Wait 2 to 3 minutes to allow air to be vented. Then add coolant to bring the level to the top.

Section A-Adjustment, Replacement and Repair B Series

Close the drain valves. Fill the cooling system with a mixture of 50% water and 50% ethylene-glycol type antifreeze. This will provide freeze protection to -37°C [-34°F].

Coolant Capacity (Engine Only)		Liters [U.S. Quarts]	
4B3.9	6B5.9		
4BT3.9	4BTA3.9*	6BT5.9	6BTA5.9*
7.0 [7.4]	7.9 [8.4]	9 [9.5]	9.9 [10.5]

*4BTA and 6BTA engines use a jacket-water aftercoolers. If a charge air aftercooler is used, the coolant capacity is the same as the naturally aspirated or turbocharged only engines.

Install the pressure cap. Operate the engine until it reaches a temperature of 80°C [180°F], and check for coolant leaks.

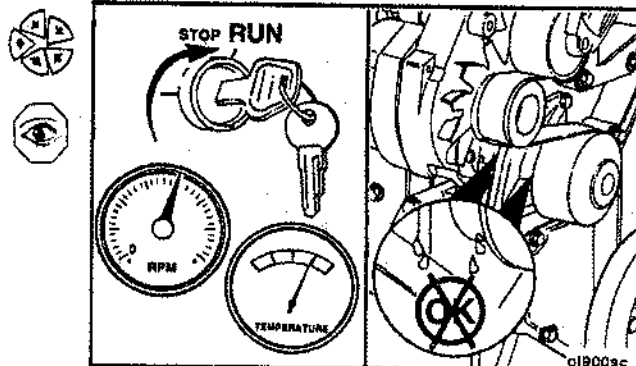
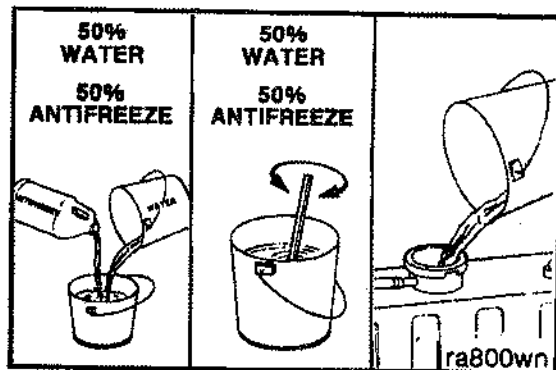

Thermostat-Replacement

Preparatory Steps:

- Disconnect the negative battery cable.
- Drain 2 liters (2.1 U.S. Quarts) of coolant.
- Remove the radiator hose from the outlet connection.
- Remove the drive belt.

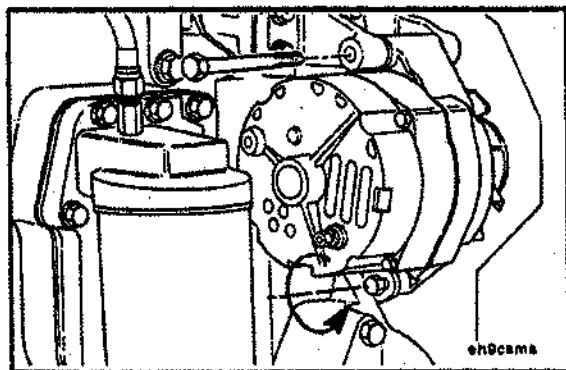

14 mm, 16 mm

- Loosen the lower alternator link capscrew.
- Remove the upper alternator mounting capscrew.

Section A-Adjustment, Replacement and Repair
B Series

Lower the alternator.

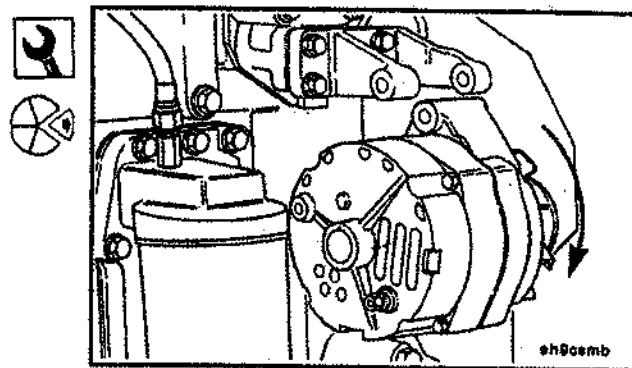

10 mm

Remove the thermostat housing, lifting bracket, thermostat and thermostat seal.

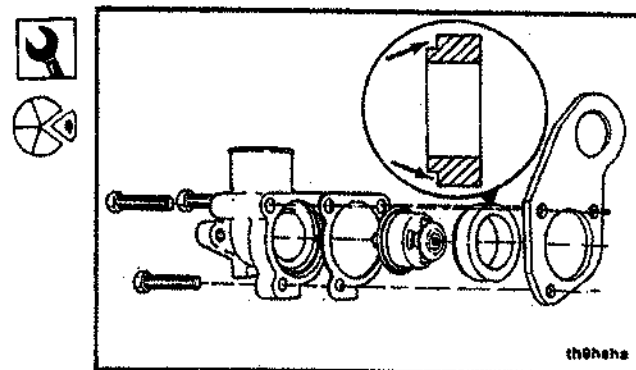

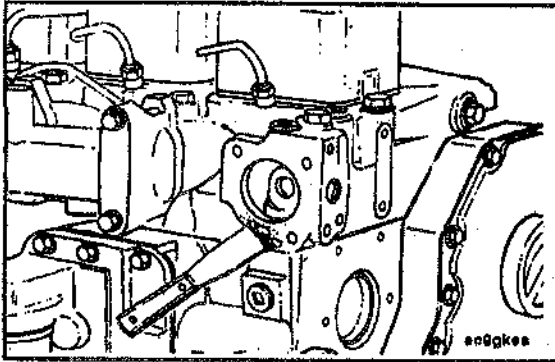

Clean the gasket surfaces.

NOTE: Do not let any debris fall into the thermostat cavity when cleaning gasket surface.

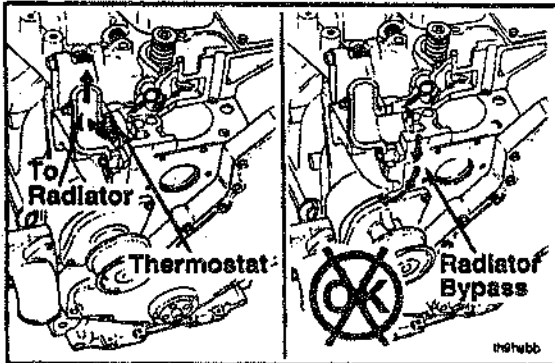

Caution: Always use the correct thermostat and never operate the engine without a thermostat. An incorrect thermostat can cause the engine to overheat or run too cold. The engine will overheat if operated without a thermostat because the coolant flows back to the inlet of the water pump instead of through the radiator for cooling.

Section A-Adjustment, Replacement and Repair
B Series

Assemble the removed parts in the reverse order of removal.

Make sure the gasket is aligned with the capscrew holes. Install the capscrews and use your fingers to tighten.

The notched end of the rubber thermostat seal points away from the cylinder head.

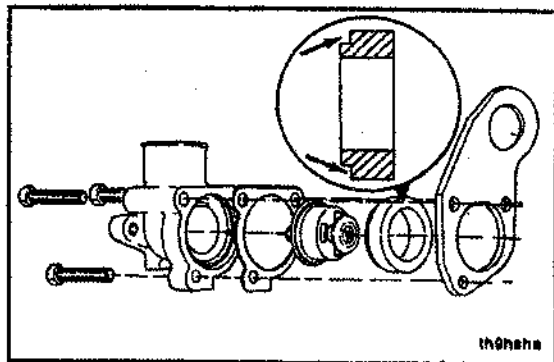

10 mm

Tighten all Capscrews.

Torque Value: 24 N•m

[18 ft-lb]

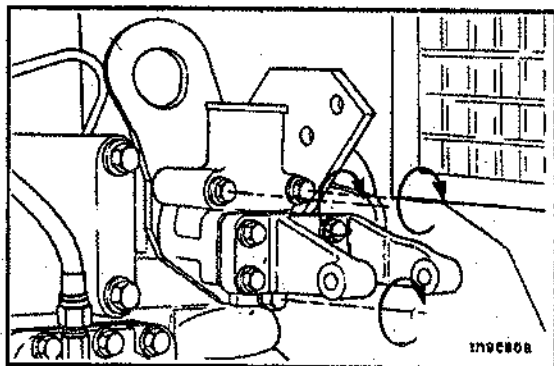

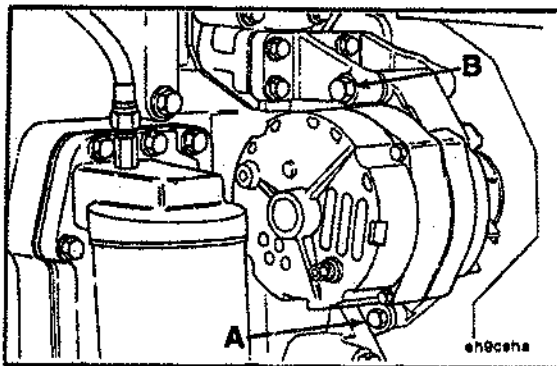

14 mm, 16 mm



Torque Value:

(A) 24 N·m [18 ft-lb]

(B) 43 N·m [32 ft-lb]



13 mm

Install the drive belt.



NOTE: After the tensioner has been raised to remove/install the belt, check the torque of the tensioner cap screw.



Torque Value: 43 N · m [32 ft-lb]

Section A-Adjustment, Replacement and Repair
B Series

Fill the cooling system. Operate the engine and check for leaks.

Caution: Be sure to vent the engine and aftercooler during filling, to remove air from the coolant system or over-heating will result.

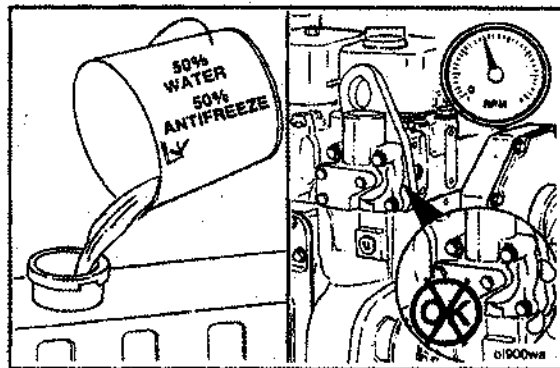

Fuel System Repair Summary

Component To Be Replaced	Tools	Preparatory Steps
Lift Pump	13,14 and 17 mm Wrenches	Clean debris.
High Pressure Lines	13 mm Socket, 14,17, and 19mm Open End Wrenches and a Torque Wrench	Clean debris.
Injector Fuel Drain Manifold	10 mm and 19 mm Open End Wrenches, 10 mm and 13 mm Sockets, and a Torque Wrench	
Injectors	Ratchet, 24 mm Socket (deep well), and a Torque Wrench	Disconnect the high pressure lines and fuel drain manifold.
	Injector bore cleaning brush.	
Injection Pump	10 mm Wrench, Ratchet, 22 mm Socket, 75 mm T-Bar Puller (w/2 8 mm capscrews) 1/2 in. open end wrench flat Screwdriver 13 mm Socket, 13 mm Wrench, Hammer, flat Chisel and a Torque Wrench.	Remove high pressure lines, supply line and return line. Remove the AFC air line, oil line (s), fuel shutoff solenoid and control linkage.
Fuel Solenoid	Robert Bosch 24 mm Wrench, Lucas CAV 22 mm Wrench	Label and disconnect wiring.
Fuel Filter Head	24 mm, 75-80 mm and 90-95 mm Filter Wrench	Clean debris.

**Section A-Adjustment, Replacement and Repair
B Series**

Fuel System Repair-Rotary Pump

Fuel System Components-Cleaning

Thoroughly clean all fittings and components before removal. Make sure that the debris, water, steam, or cleaning solution does not reach the inside of the fuel system.

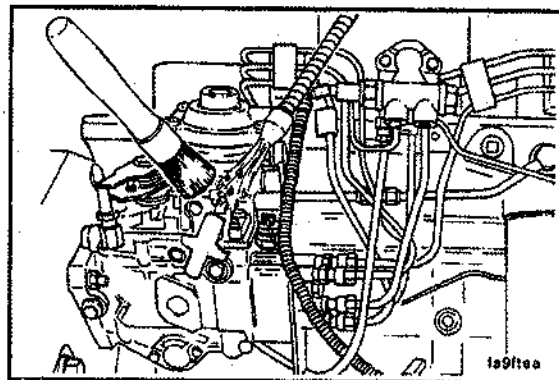

Low Pressure Fuel Line-Replacement

Preparatory Step:

- Clean all debris from around the fittings.

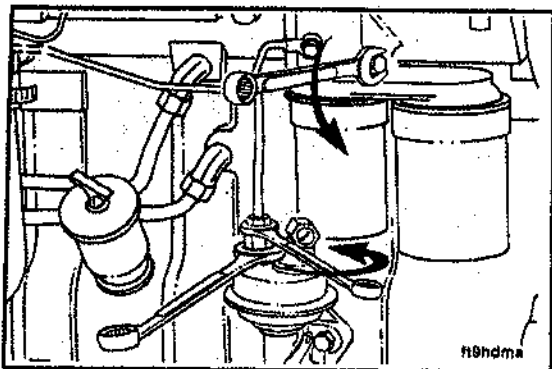

14 mm, 17 mm

Disconnect the fuel line from the lift pump and filter head.
Use two wrenches to disconnect the line from the lift pump.

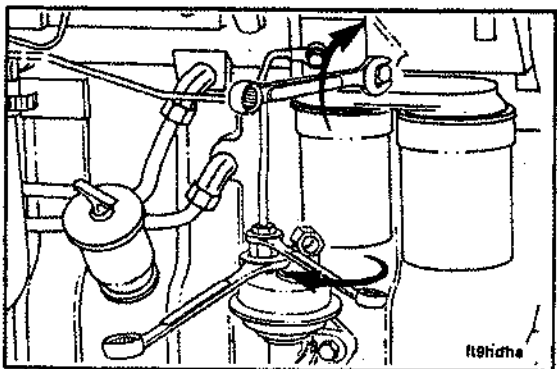

14,17 mm

Install the fuel line to the lift pump and filter head. Use two wrenches to tighten the connection to the lift pump.



NOTE: Do not overtighten the connection. Fuel leaks can result from overtightening.



Torque Value: 24 N•m [18 ft-lb]

Fuel Filter Head Adapter-Replacement

Preparatory Steps:

- Clean debris.
- Remove fuel filters.

24 mm

Remove the retaining nut, filter head adapter and sealing washers.

Install in the reverse order of removal.

Torque Value: 32 N·m [24 ft-lb]

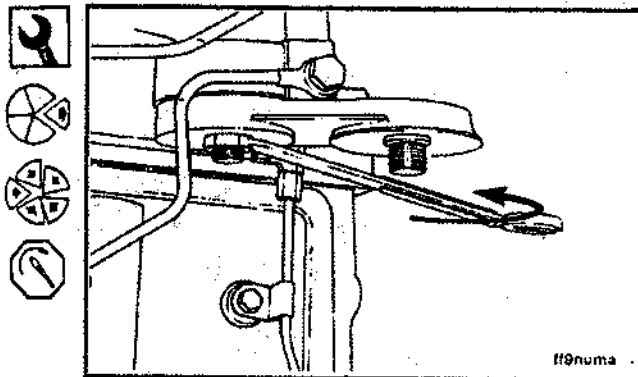

Lift Pump-Replacement

Preparatory Steps:

- Clean debris from around the lift pump.

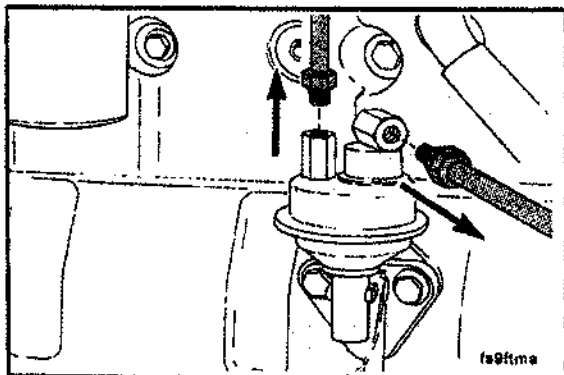

14 mm, 17 mm



Disconnect the fuel lines.

Section A-Adjustment, Replacement and Repair
B Series

10 mm

Remove the lift pump and clean the mounting surface on the cylinder block.

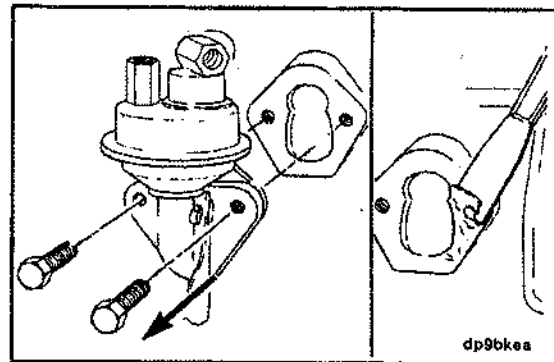

10 mm

Install the lift pump and a new gasket.

Connect the fuel lines.

Torque Value: 24 N·m [18 ft·lb]

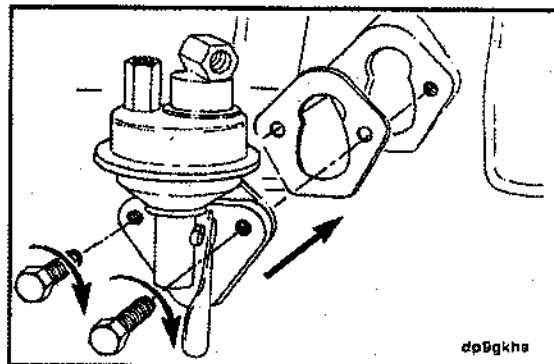

High Pressure Fuel Lines-Replacement

Preparatory Steps:

- Clean all debris from around the fittings.

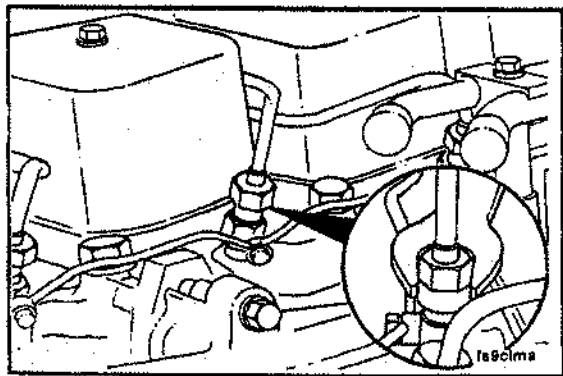

17 mm



NOTE: If individual lines are to be replaced, remove the support clamp from the let of lines containing the line to be replaced.

Disconnect the line (s) from the injectors.

Section A-Adjustment, Replacement and Repair B Series

17 mm

Disconnect the line (s) from the fuel pump. Install protective covers to the injectors and delivery valves to prevent the entry of dirt into the system.

Caution: Install the support clamp in original position and , to prevent damage from high frequency vibration, make sure the lines have not been bent or do not contact each other or another component.

NOTE: To prevent damage to the fuel lines, they must be connected to the injectors and fuel injection pump in a free state without forcing the connecting nuts. The fuel lines are correctly sized for each application and bending the lines is **not** acceptable.

Install the lines in the reverse order of removal.

Torque Value:

(Line Fittings)	30 N•m	[22 ft-lb]
(Support Clamp)	6 N•m	[4 ft-lb]
(Support Bracket)	24 N•m	[18 ft-lb]

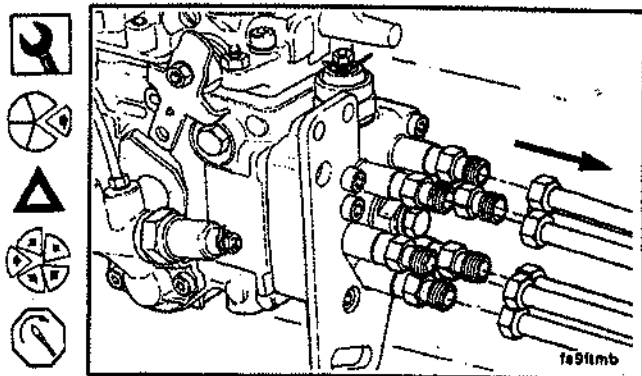

Fuel Drain Manifold-Replacement

Preparatory Steps:

- Clean debris.

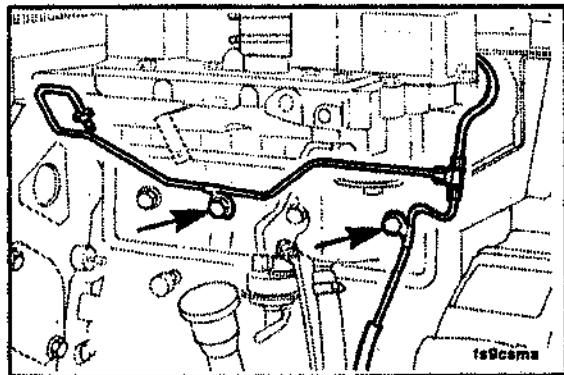

10 mm



Remove the capscrew from the hold-down clamp.

**Section A-Adjustment, Replacement and Repair
B Series**

10 mm

Remove the banjo fitting screws and washers.

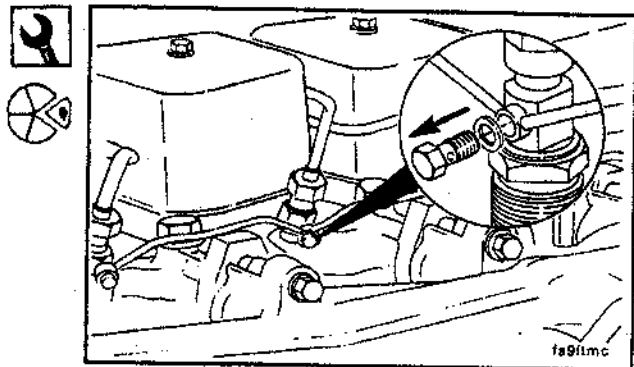

17 mm

Disconnect the drain line fitting from the injection pump.

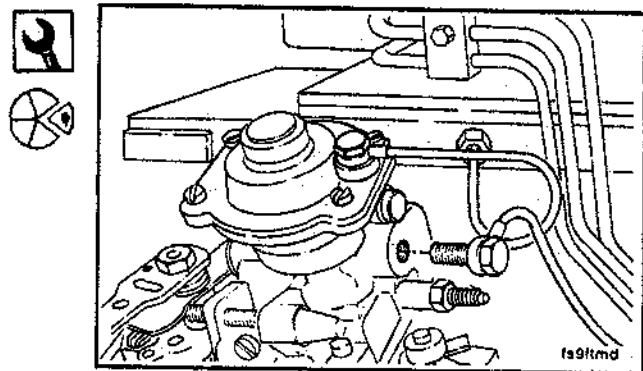

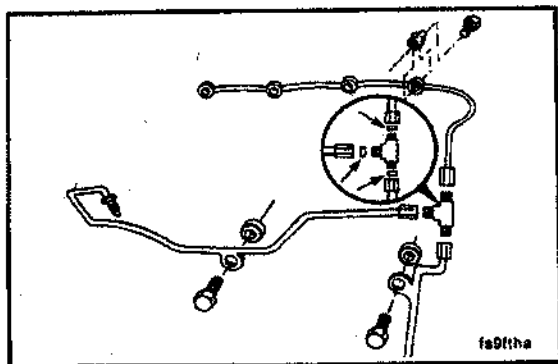

NOTE: Use new seals and sealing washers.

Assemble the drain line and fuel drain manifold in the reverse order of removal.

Torque Value:

(Banjo fitting screw)	15 N•m	[11 ft-lb]
(Banjo fitting)	9 N•m	[7 ft-lb]
(Clamp screw)	24 N•m	[18 ft-lb]

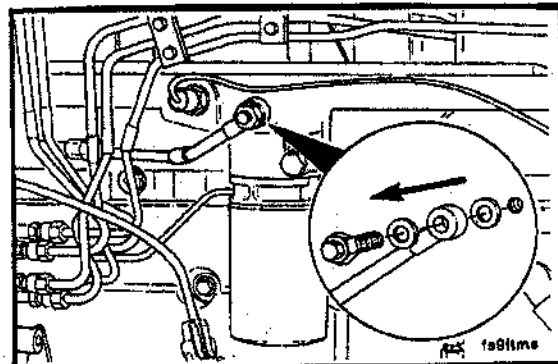

Injection Pump Supply Line-Replacement



17 mm

Remove the bleed screw banjo fitting.

Section A-Adjustment, Replacement and Repair
B Series

14 mm, 16 mm, 17 mm

Remove the supply line (Bosch Injection Pump).

Replace the seals (1) in the fittings if the line is disassembled.

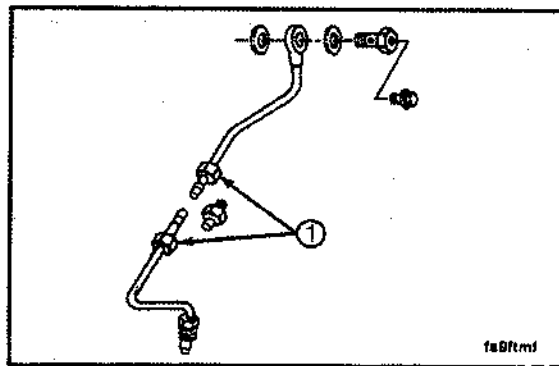

14,16,19 and 24 mm

The Lucas CAV pump has two fittings for the supply line.

Replace the seals in the fittings if the line is disassembled.

Replace banjo fitting sealing washers (1) and ferrules (2) each time they are removed.

Torque Value: 32 N·m [24 ft-lb]

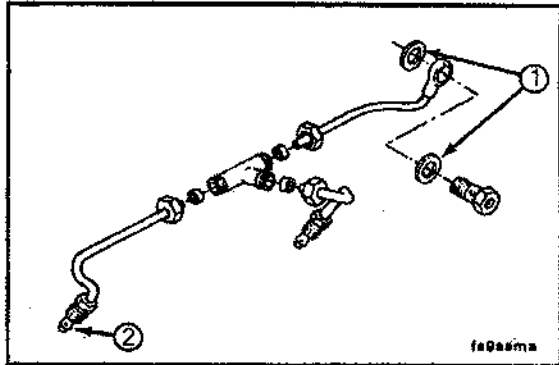

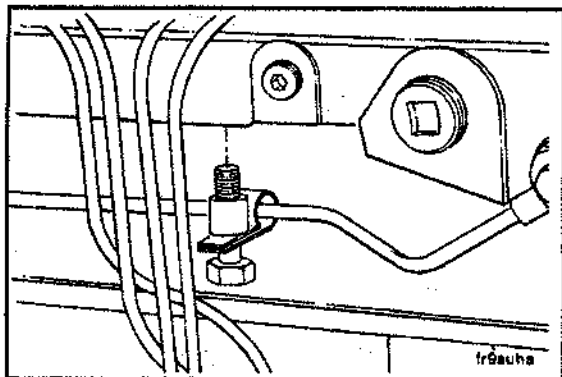

17 mm

Engines rated at 2500 RPM and above require additional fuel line support. Install as illustrated.

Torque Value: 24 N·m [18 ft·lb]

Injectors-Replacement

Preparatory Steps:

- Thoroughly clean around the injectors.
- Disconnect the high pressure fuel lines.
- Disconnect the fuel drain manifold.

**Section A-Adjustment, Replacement and Repair
B Series**

16 mm, 24 mm Box Wrench

Caution: The injector must not rotate in the bore of the cylinder head. This will damage the cylinder head.

Remove the injectors.

Hold the injector body with the 16 mm wrench while you loosen the hold-down nut with a 24 mm box end wrench.

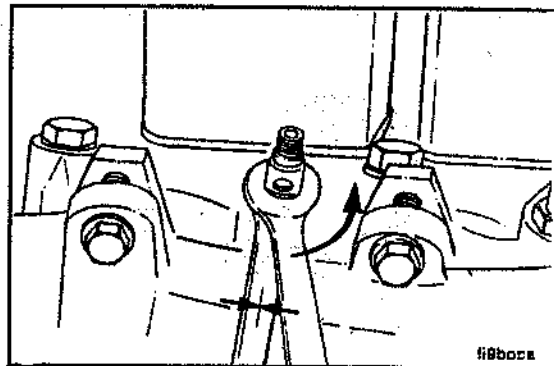

Clean the injector nozzle bore using Service Tool No. 3822509.

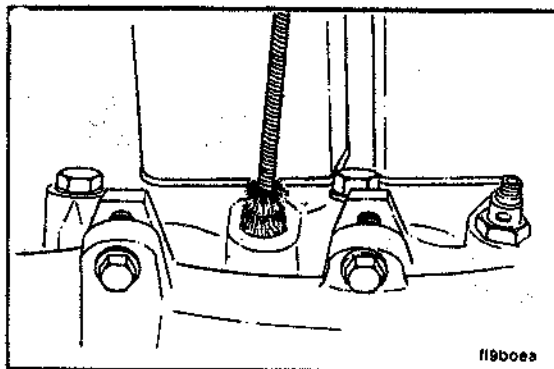

Section A-Adjustment, Replacement and Repair
B Series

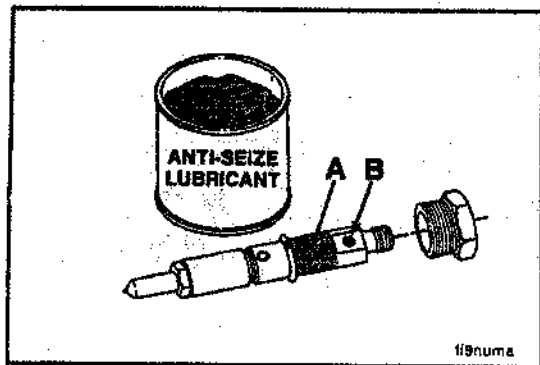

Remove the injector hold-down nut and apply a coat of anti-seize compound to injector surface (A). Avoid getting anti-seize compound in the fuel drain hole (B).

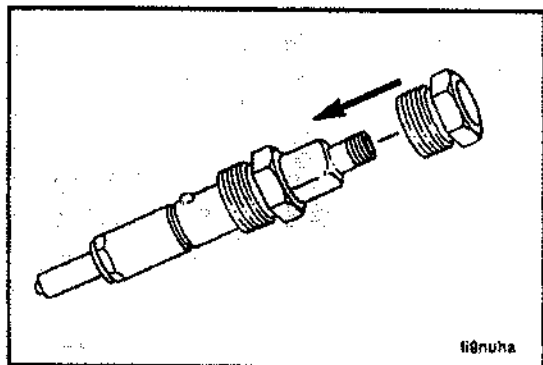

Install the hold-down nut on the injector body.

Section A-Adjustment, Replacement and Repair B Series

Install a new o-ring into the recessed groove on the top of the hold-down nut. Make sure the o-ring is not cut or wisted when installing (BOSCH and Stanadyne). CAV injectors retain the o-ring inside the hold-down nut.

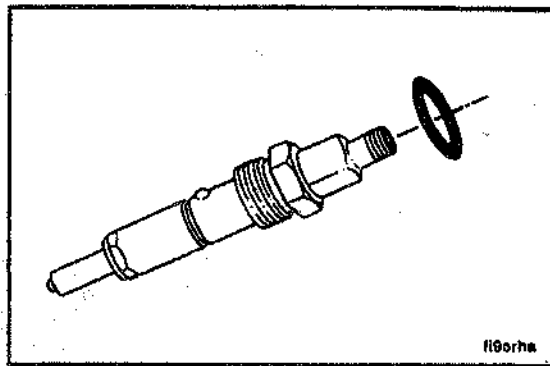

Apply a coat of anti-seize compound to the threads of the injector hold-down nut.

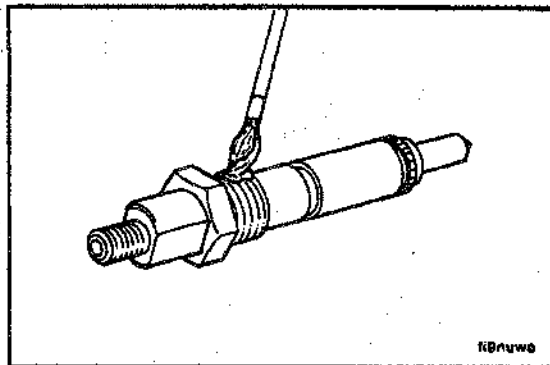

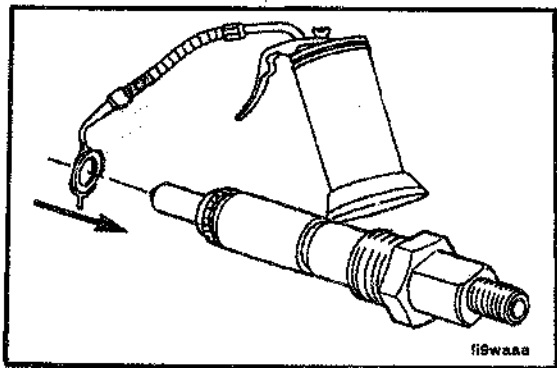

Assemble the injector and new copper washer.

Use only one copper washer.

Service Tip: A light coat of clean 15W40 engine oil between the washer and injector can help to keep the washer from falling during installation.

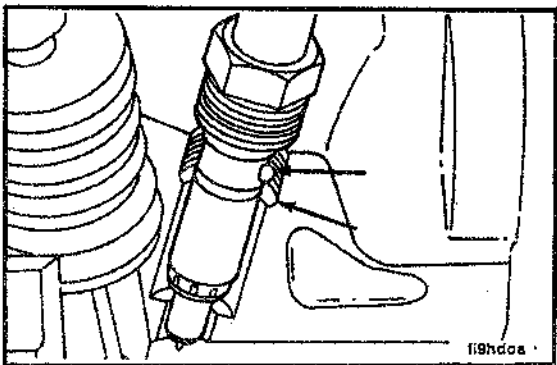

24 mm Install the Injectors

The protrusion on the side of the nozzle fits into a notch in the head to orient the injector.



Tighten the injector nozzle nuts.



Torque Value: 60 N·m [44 ft·lb]

Section A-Adjustment, Replacement and Repair
B Series

10 mm

Install the fuel drain manifold.

Torque Value: 9 N•m [7 ft-lb]

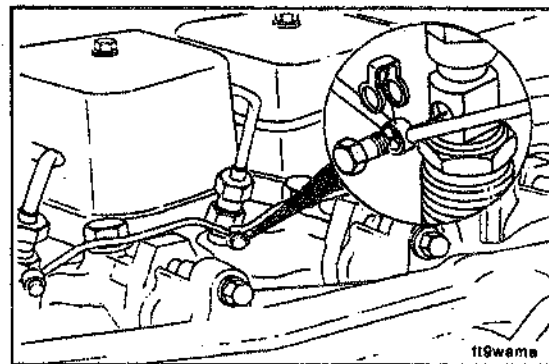

17 mm

Install the high pressure fuel lines.

Torque Value: 30 N•m [22 ft-lb]

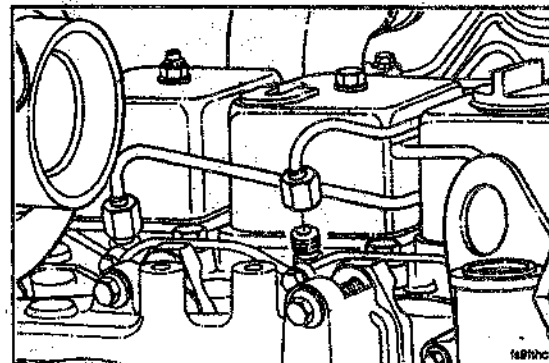

Fuel Shut Off Solenoid-Replacement

Preparatory Steps:

- Label and disconnect the wiring.

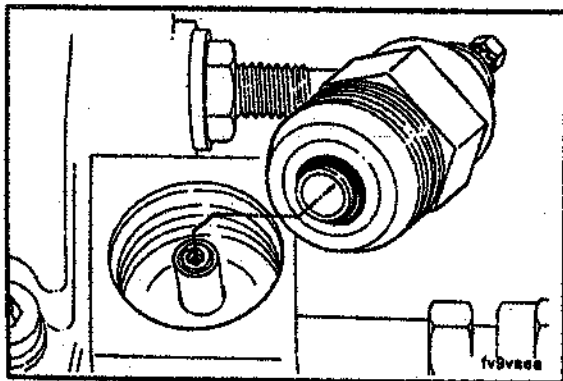

Bosch and CAV

22 mm-CAV



24 mm-Bosch

Clean around the valve.



**WHEN REMOVING THE VALVE, BE CAREFUL NOT TO
DROP THE PISTON AND SPRING.**

Replace the valve and connect the electrical wire.

**Section A-Adjustment, Replacement and Repair
B Series**

Stanadyne DB4

- Remove the electrical wiring.
- Remove the fuel drain line.
- Remove the throttle shutoff linkage.
- Remove the fuel injection pump top cover.
- Disassemble the fuel injection pump top cover.

5/16 Inch

Install new insulating tubes onto the terminals on the terminal studs of the new solenoid.

Install the valve into the cover.

Torque Value: 14 N•m [12 in-lb]

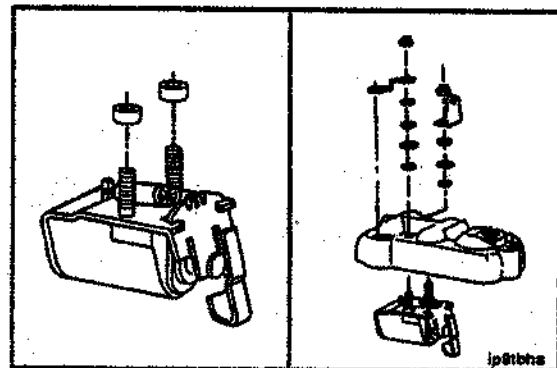
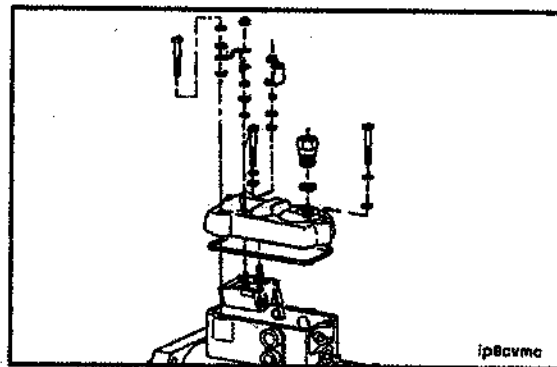

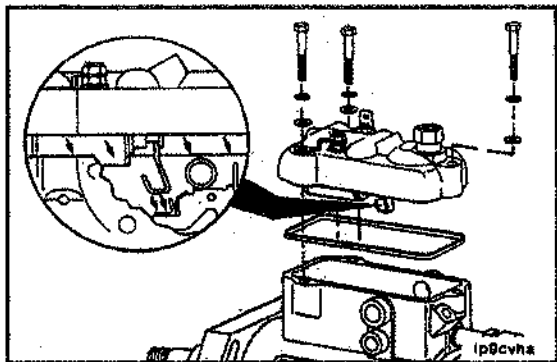

5/16 Inch

Install the cover and gasket onto the fuel injection pump.

NOTE: Extreme care must be taken in assembling the cover to a fuel injection pump to make sure the shutoff arm is in proper with the linkage hook tab.

Install the cover to pump at a downward angle from the drive shaft end of the fuel injection pump, then slide the cover horizontally into position.

Torque Value: 4.6 N•m [41 in-lb]

KSB Replacement

T30 TORX, 12 mm

Disconnect the wiring harness from the KSB solenoid (1). Disconnect the fuel lines (2). Replace the KSB, fuel lines and wiring harness.

Torque Value:

Fuel Line Banjo Fittings:	12 N•m	[9 ft-lb]
KSB Mounting Nuts	9 N•m	[7 ft-lb]

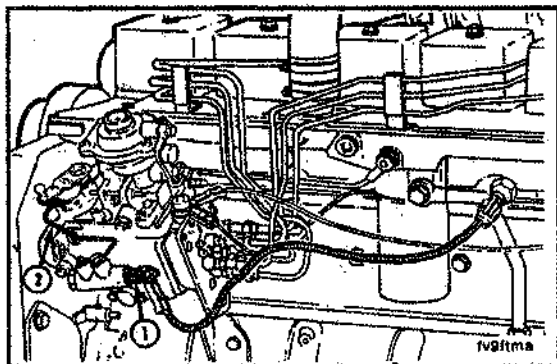

Section A-Adjustment, Replacement and Repair B Series

KDB Temperature Switch Replacement

27 mm

Disconnect the KSB (1) wiring harness (2) from the switch (3). Replace the temperature switch. Install the wiring harness.

Torque Value: 24 N·m [18 ft-lb]

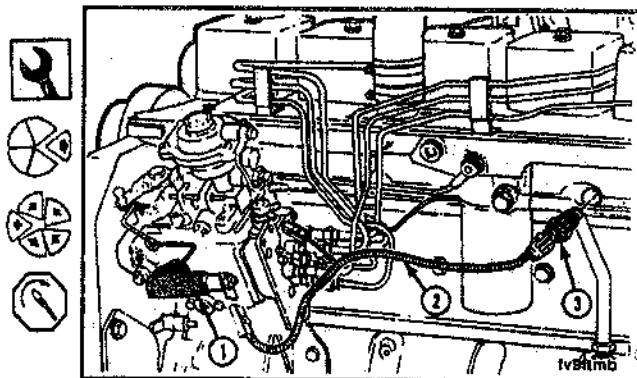

Fuel Pump-Replacement

Preparatory Steps:

- Remove all fuel lines.
- Remove control linkage.
- Remove fuel shut off solenoid.

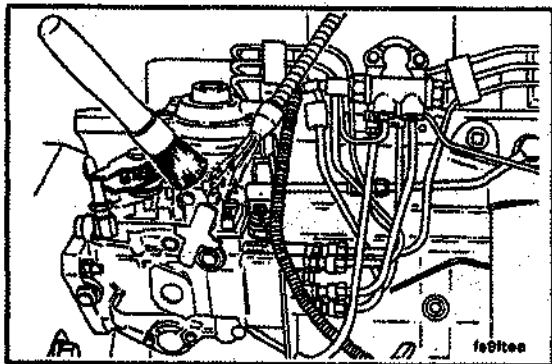

NOTE: A diesel engine cannot tolerate dirt or water in the fuel system. A tiny piece of dirt or a few drops of water in the injection system may stop your unit.

Clean all external surfaces of the injection pump, including all line connections and fittings that are to be disconnected. Clean the area around the injection pump gear cover to prevent dirt from entering the crankcase.

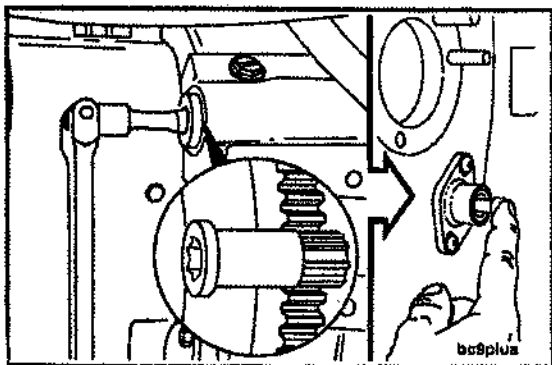

Removing the Fuel Pump

Locate TDC for cylinder number 1. Push the TDC pin into the hole in the camshaft gear while slowly barring the engine.

To prevent damage to the timing pin, be sure to disengage the pin after locating TDC.

Section A-Adjustment, Replacement and Repair B Series

14 mm

Loosen the CAV injection pump lockscrew and position the special washer, then tighten the lockscrew against the pump drive shaft.

Torque Value: 7 N·m [5 ft-lb]

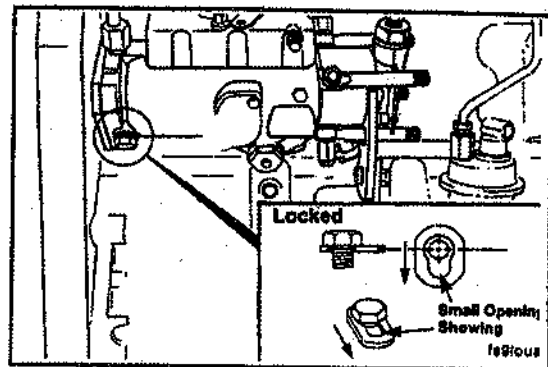

3/8 Inch

Loosen the Stanadyne DB4 fuel injection pump lock screw and position the special washer. Tighten the lock screw until contact is made with the fuel injection pump drive shaft.

Torque Value: 12 N·m [9 ft-lb]

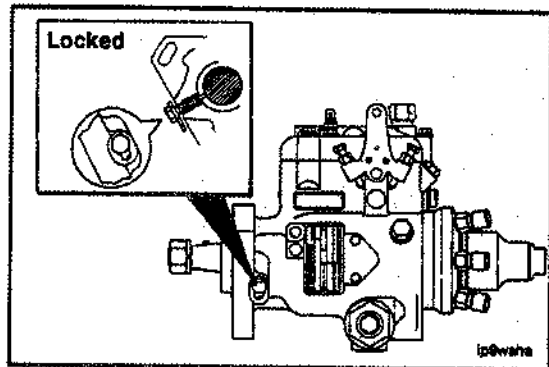

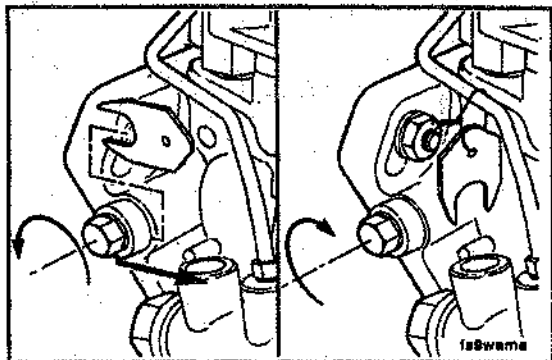

10 mm

The special washer on the Bosch injection pump must be removed so the lockscrew can be tightened against the drive shaft.



Torque Value: 30 N·m [22 ft-lb]

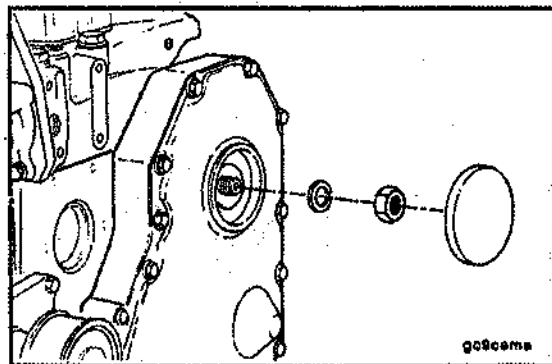

22 mm

Remove the gear cover access cap.



Remove the nut and washer from the fuel pump shaft.

**Section A-Adjustment, Replacement and Repair
B Series**

75 mm T-Bar Puller

Pull the fuel pump drive gear loose from the shaft.

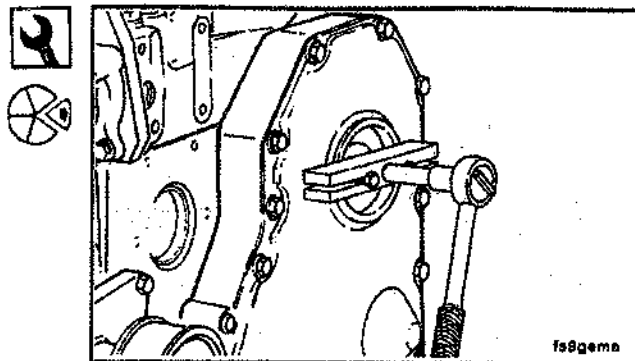

Caution: Do not remove the control lever. The lever is indexed to shaft during pump calibration. Removal of the lever will alter the fuel pump calibration and effect engine performance.

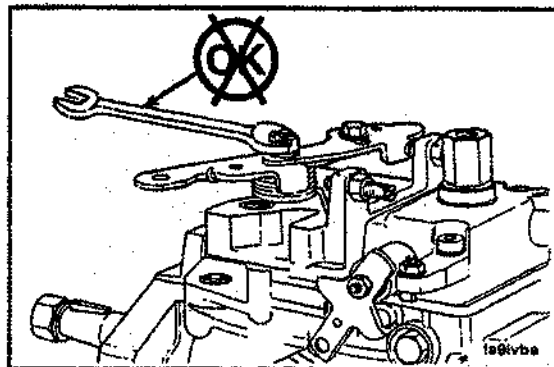

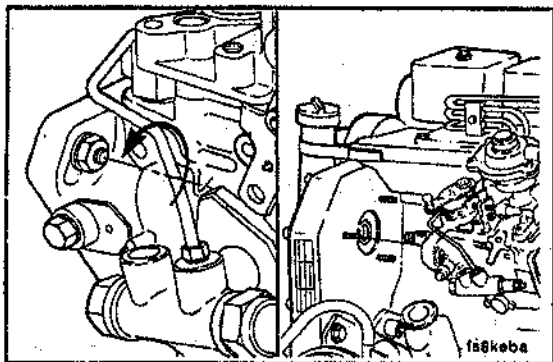

13 mm

NOTE: Do not drop drive gear key when removing pump.

Remove the three mounting nuts.

Remove the fuel pump.

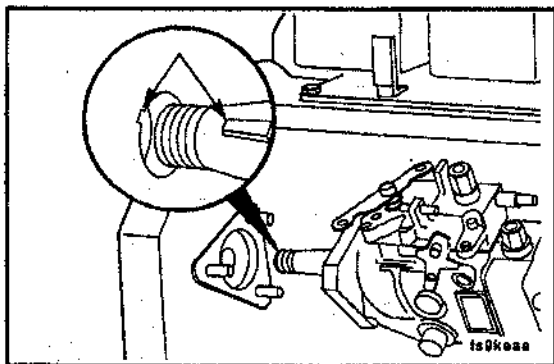

Installing the Fuel Pump

Make sure the engine has cylinder number 1 at TDC.

The keyway in the shaft of new and reconditioned pumps will be locked in a position corresponding to the keyway in the drive gear when cylinder number 1 is at TDC on the compression stroke.

After verifying that Cylinder Number 1 is at TDC, install the pump. Make sure the key does **not** fall into the gear housing.

Section A-Adjustment, Replacement and Repair B Series

Attach the pump by finger tightening the three mounting nuts. The pump must be free to move in the slots.

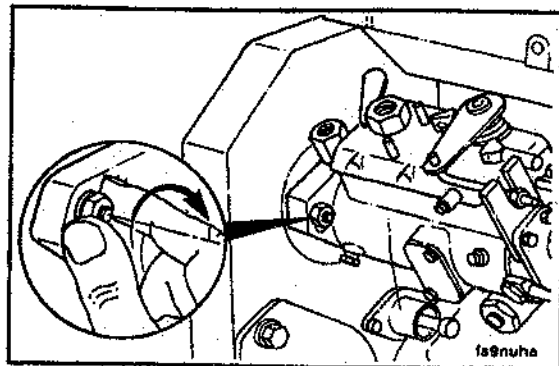

22 mm (CAV Stanadyne), 24 mm (Bosch)

Attach the pump drive shaft nut and spring washer. The pump may rotate slightly due to gear helix and clearance. This is acceptable providing the pump is free to move on the flange slots and the crankshaft does not move.

NOTE: Do not overtighten. This is not the final torque.

Torque Value: 15 to 20 N•m [11 to 15 ft-lb]

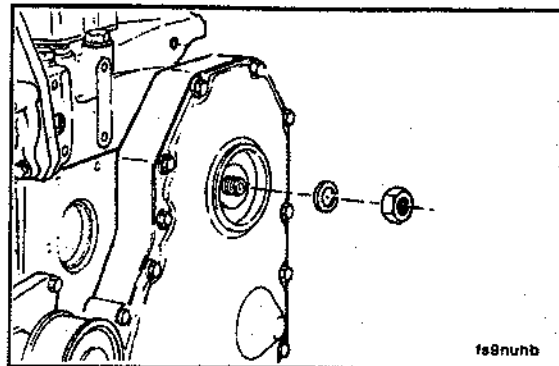

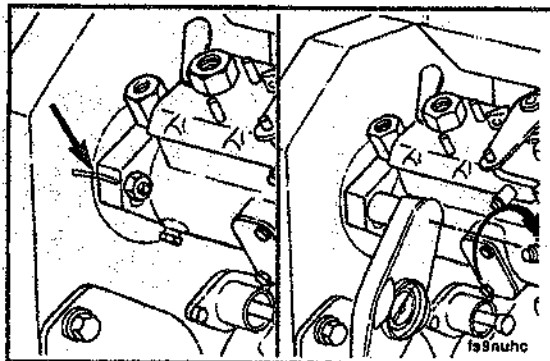

13 mm

If reinstalling the removed pump, install the pump onto the engine. Rotate the pump to align the scribe marks. Tighten the three mounting nuts.



Caution: The pump shaft must be unlocked after installation to prevent pump damage.

Torque Value: 24 N·m [18 ft-lb]

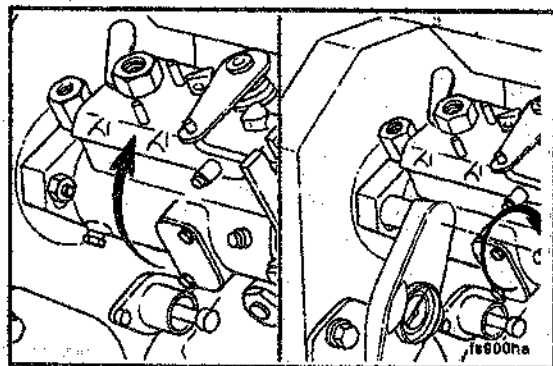

13 mm

If installing a new or rebuilt pump without scribe marks, take up gear lash by rotating the pump against the direction of drive rotation.



Tighten pump retaining nuts.

Torque Value: 24 N·m [18 ft-lb]

Section A-Adjustment, Replacement and Repair B Series

If a new or rebuilt pump is being installed, permanently mark the injection pump flange to match the mark on the gear housing.

14 mm

Loosen the CAV pump lockscrew and position the special washer behind the lockscrew head.

Tighten the pump lockscrew.

Torque Value: 20 N•m [15 ft-lb]

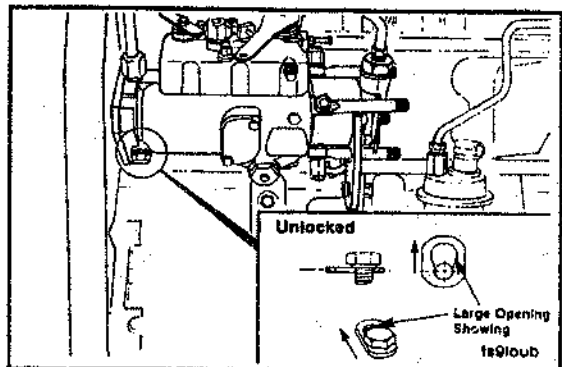
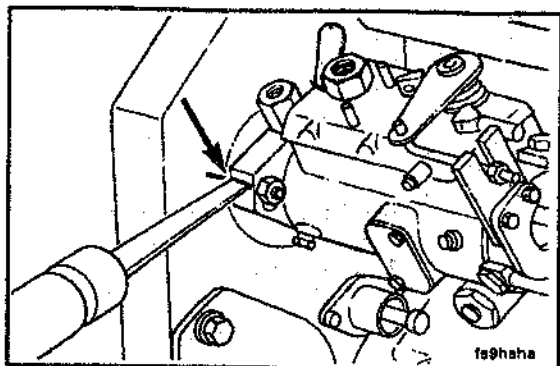

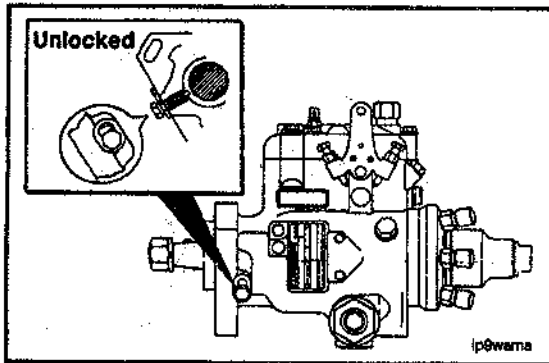

3/8 Inch



Loosen the Stanadyne DB4 fuel injection pump lock screw and position the special washer behind the lock screw head.

Tighten the lock screw.

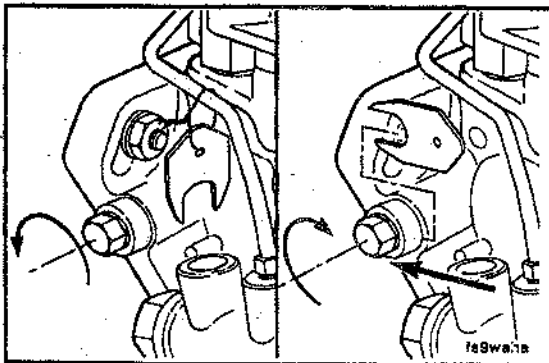

10 mm



NOTE: On the Bosch pump, the special washer is wired to the pump and must be installed under the lock screw.

Tighten the pump lock screw.



Torque value: 13 N·m [10 ft·lb]

**Section A-Adjustment, Replacement and Repair
B Series**

NOTE: Be sure to disengage the timing pin.

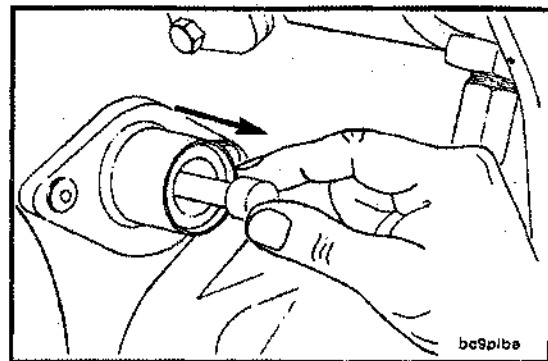

10 mm

Install the injection pump support bracket. Finger tighten all capscrews before final tightening.

NOTE: Tighten the bracket to block mounting capscrew before tightening the bracket to injection pump capscrews.

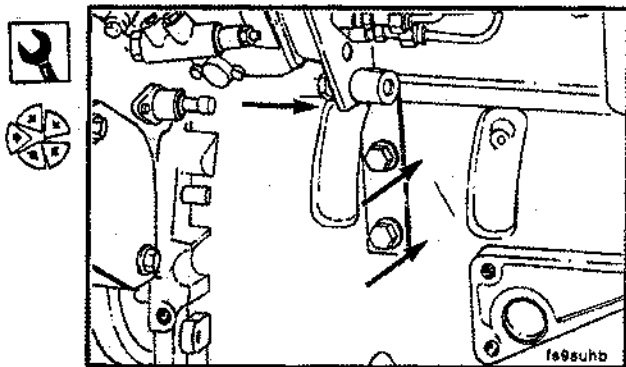

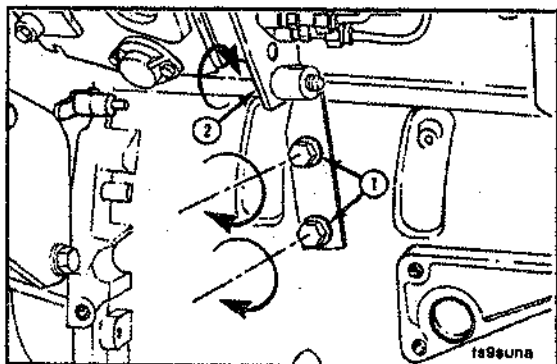

Torque Value: 24 N•m [18 ft-lb]

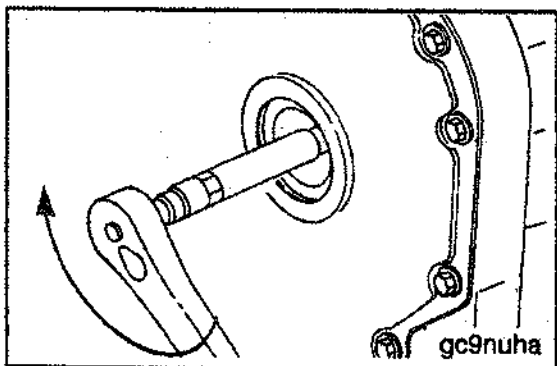

22 mm

Tighten the drive gear mounting nut.



Install the access cap.



Torque Value: Bosch 60 N•m [48 ft-lb]
Stanadyne 65 N•m [48 ft-lb]

Section A-Adjustment, Replacement and Repair
B Series

8 mm

Install the solenoid wiring and all fuel lines.

NOTE: When connecting the cable/rod to the control lever, adjust the length so the lever has stop-to-stop movement.

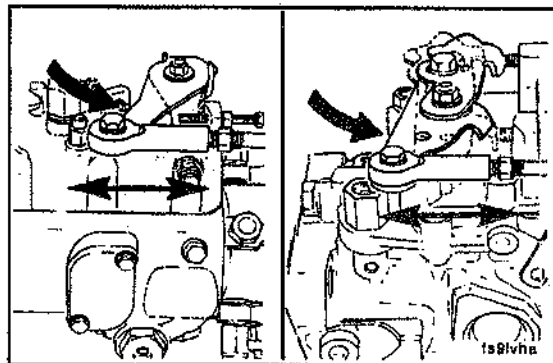
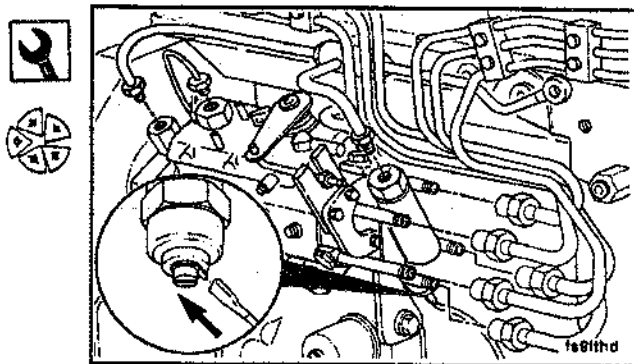

Section A-Adjustment, Replacement and Repair
B Series

NOTE: Similarly adjust the length of the cable/rod to the mechanical shut down lever so there is a stop-to-stop movement.

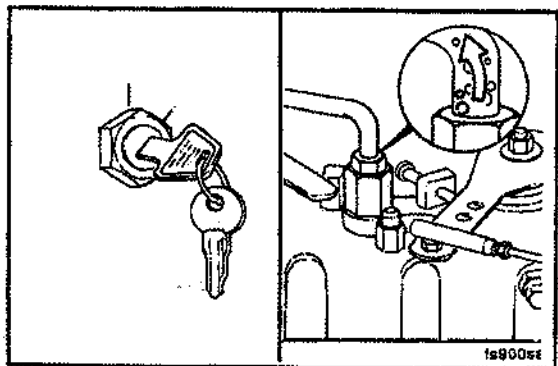
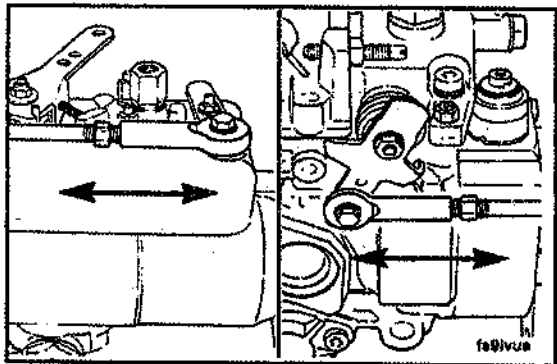

Bleed all air from the fuel system.

Section A-Adjustment, Replacement and Repair B Series

If necessary, adjust the idle speed.

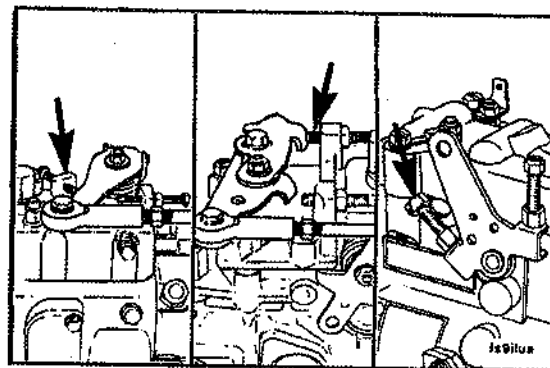

Fuel System Repair-In-Line Pump

Fuel system Components-Cleaning

Thoroughly clean all fittings and components before removal. Make sure that the debris, water, steam or cleaning solution does **not** reach the inside of the fuel system.

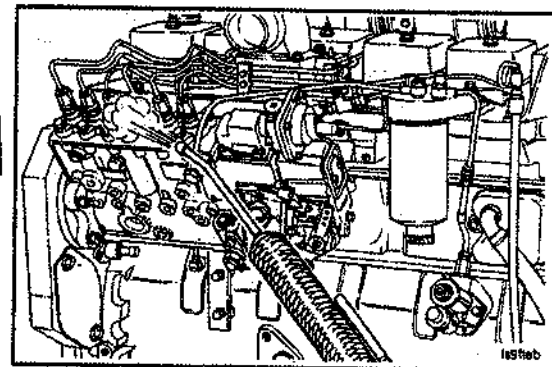

Low Pressure Fuel Line-Replacement

Preparatory Step:

- Clean debris from fittings

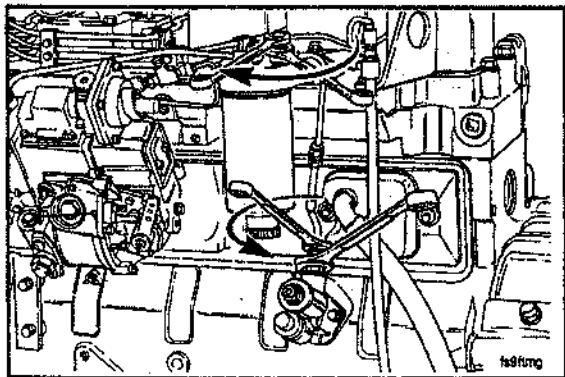

14 mm, 17 mm, 20 mm



Disconnect the fuel line from the lift pump and filter head.
Use two wrenches to disconnect the line from the lift pump.

Section A-Adjustment, Replacement and Repair B Series

14 mm, 17 mm, 20 mm

Install the fuel line to the lift pump and filter head. Use two wrenches to tighten the connection to the lift pump.

Torque Value: 24 N·m [18 ft-lb]

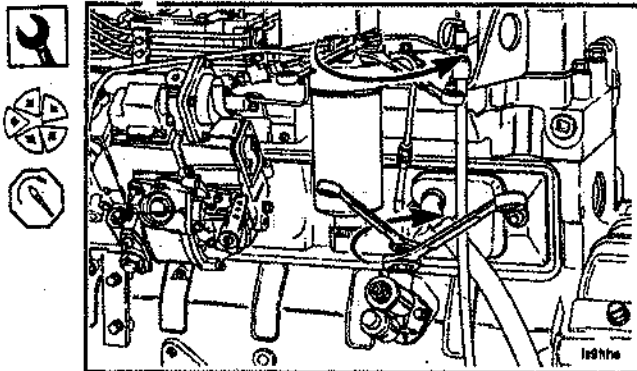

Fuel Filter Head Adapter-Replacement

Preparatory Steps

- Clean debris.
- Remove fuel filters.

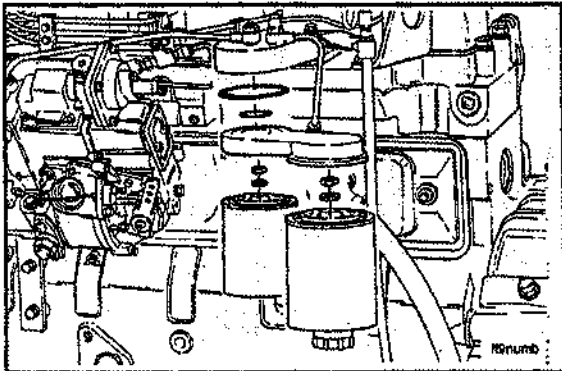

24 mm



Remove the retaining nut, filter head adapter and sealing washers.



Install in the reverse order of removal.



Torque Value: 32 N•m [24 ft-lb]



Lift Pump-Replacement

Preparatory Steps:

- Clean debris
- Disconnect the fuel lines.

Section A-Adjustment, Replacement and Repair
B Series

10 mm

Remove the lift pump.

Clean the mounting surface on the cylinder block.

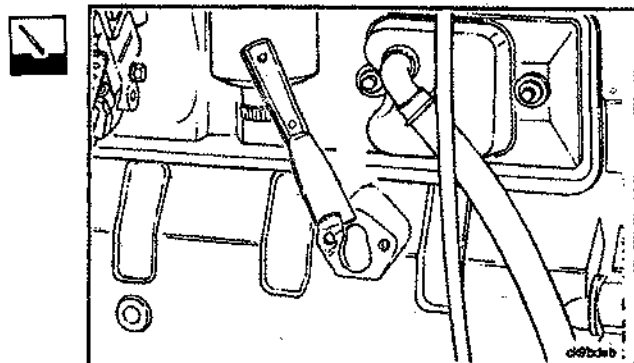
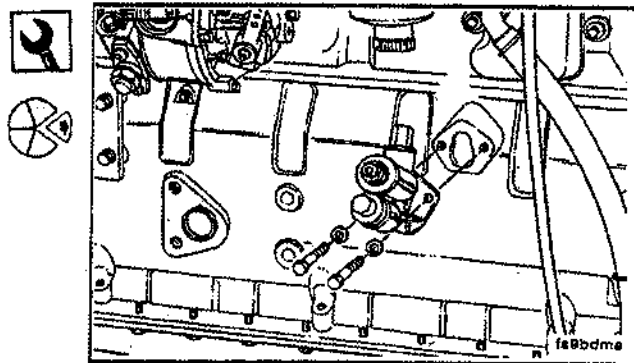

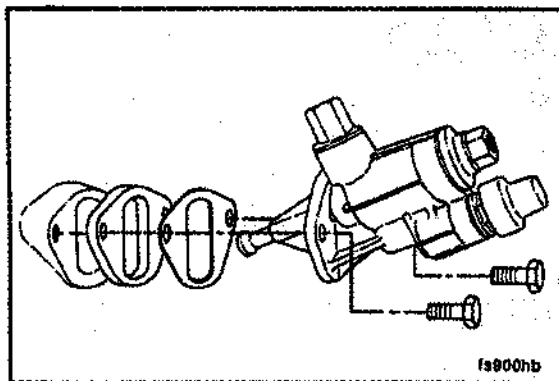

10 mm



Caution: Alternately tighten the mounting capscrews. As the capscrews are tightened, the fuel transfer pump plunger is pushed into the pump. Failure to tighten the capscrews in an even manner can result in the plunger being bent or broken.



Install the pump.

Torque Value: 24 N•m [18 ft-lb]

High Pressure Fuel Lines-Replacement

Pretaratory Steps:

- Clean debris.

Section A-Adjustment, Replacement and Repair B Series

8 mm, 17 mm, and 19 mm

NOTE: If individual lines are to be replaced, remove the support clamp from the set of lines containing the line to be replaced.

Disconnect the line (s) from the injectors.

19 mm

Disconnect the line (s) from the fuel pump.

NOTE: If removed, reinstall the support clamp in the original position and make sure the lines do not contact each other or another component. Install a protective cover on the injectors and fuel delivery valves to prevent the entry of dirt into the system.

Install the lines in the reverse order of removal.

Torque Value:

(Line Fittings) 30 N•m [22 ft-lb]

(Support Clamp) 6 N•m [4 ft-lb]

(Support Bracket) 24 N•m [18 ft-lb]

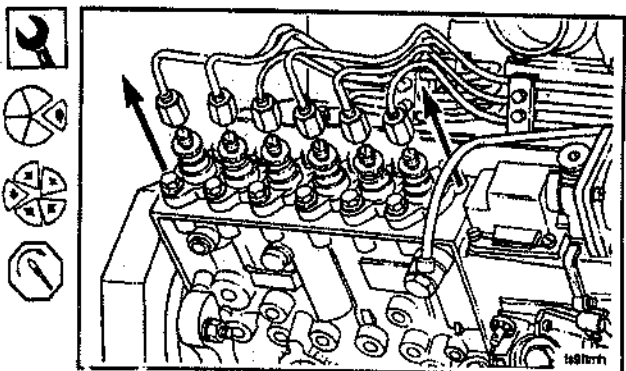
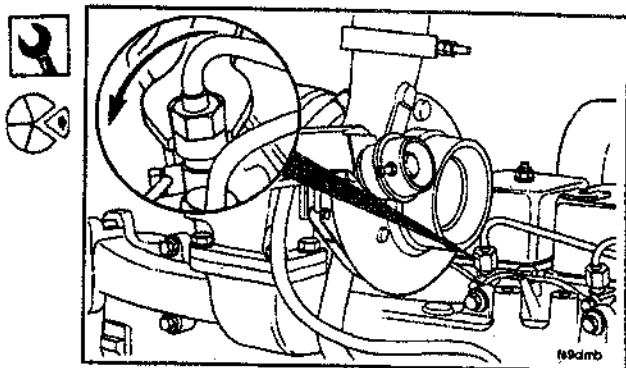

Fuel Drain Manifold-Replacement

Preparatory Steps:

- Clean debris.

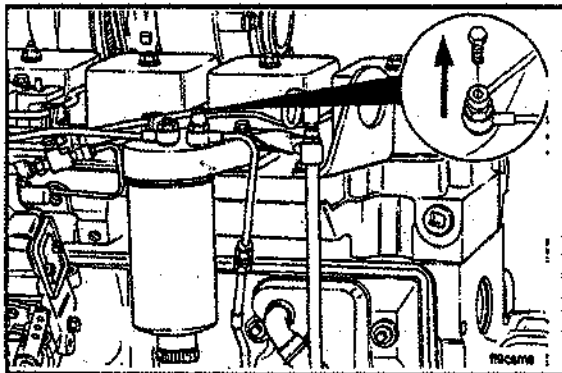

10 mm



Remove the drain line banjo capscrew from the fuel filter head. Remove the capscrew from the bracket on the intake cover.

**Section A-Adjustment, Replacement and Repair
B Series**

10 mm

Remove the banjo capscrews from the injectors.

NOTE: Use new seals and sealing washers.

Assemble the drain line and fuel drain manifold in the reverse order of removal.

Torque Value:

(Banjo fitting screw)	15 N•m	[11 ft-lb]
(Banjo fitting)	9 N•m	[7 ft-lb]
(Bracket Capscrew)	24 N•m	[18 ft-lb]

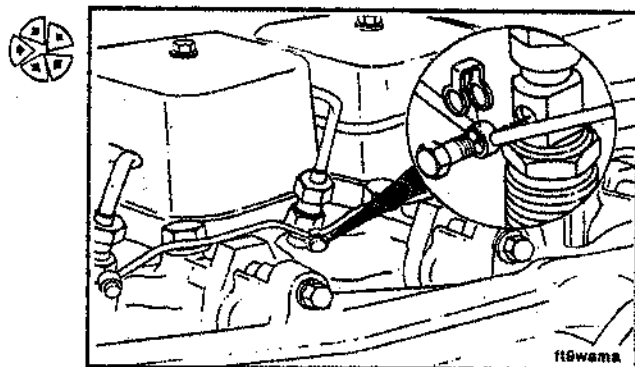
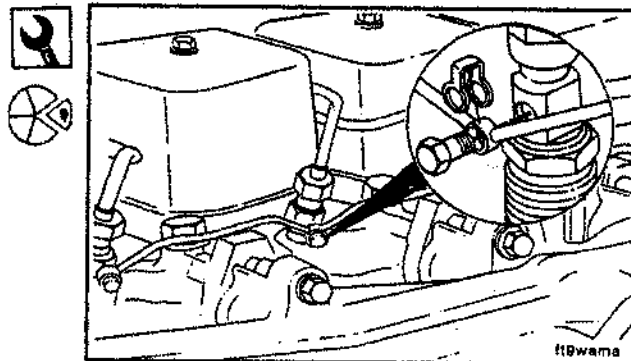

Injectors-Replacement

Preparatory Steps:

- Thoroughly clean around the injectors.
- Remove the high pressure fuel lines.
- Remove the fuel drain manifold.

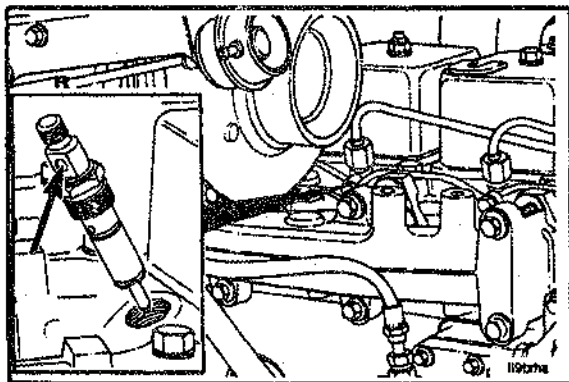

24 mm



Remove the injectors.

Section A-Adjustment, Replacement and Repair
B Series

Injector Bore Brush

Clean the injector nozzle bore, using Service Tool No. 3822509.

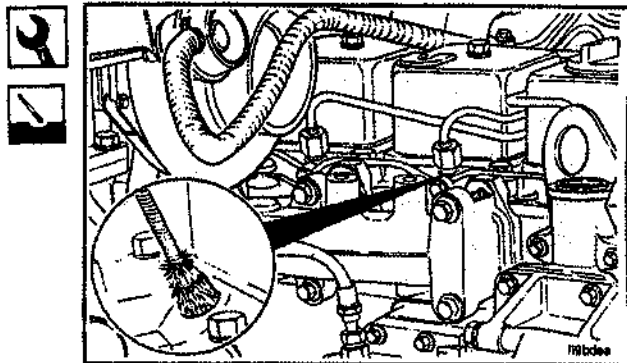

Lubricate the sealing lips of the sleeve with anti-seize compound. Package the injector, sealing sleeve, a new copper sealing washer and the holddown clamp.

Use only one washer

Service Tip: A light coat of clean 15W40 engine oil between the washer and injector can help to keep the washer from falling during installation.

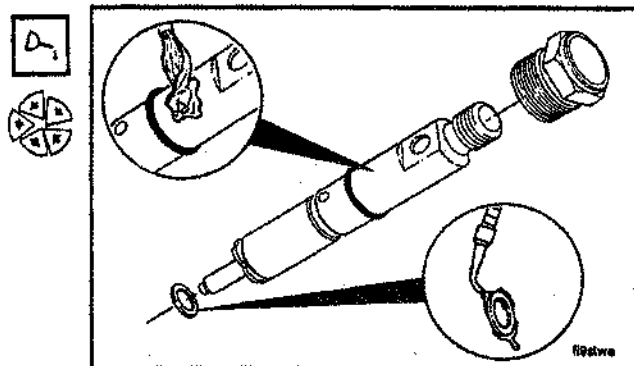

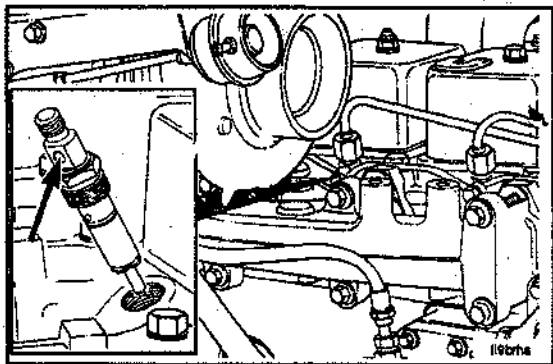

Install the injector package into the injector bore. The injector leak off connection **must** be away from the valve cover.

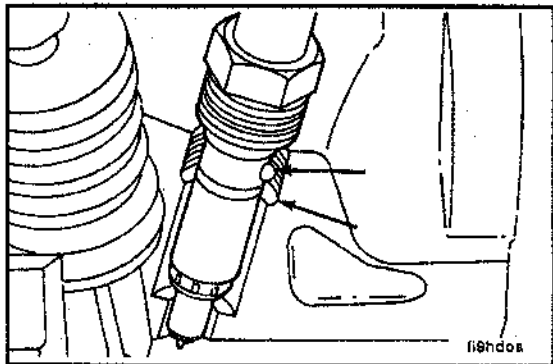

24 mm

Tighten the injector nozzle nut. The protrusion on the side of the nozzle fits into a notch in the head to orient the injector.



Torque Value: 60 N•m [44 ft-lb]

**Section A-Adjustment, Replacement and Repair
B Series**

10 mm

Install the fuel drain manifold.

Torque Value: 9 N•m [7 ft•lb]

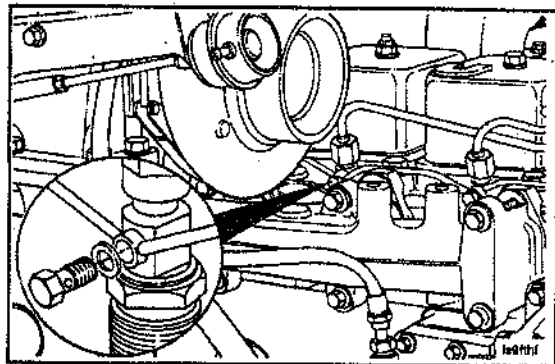

17 mm, 19mm

Install the high pressure fuel lines.

Torque value: 30 N•m [22 ft•lb]

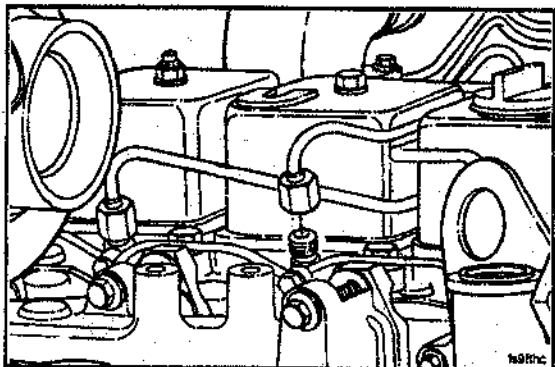

Fuel Shutoff Solenoid-Replacement

Preparatory Steps:

- Label and disconnect the wiring.

RQVK Governor Shutoff Solenoid

10 mm

Remove the hitch pin clip, mounting capscrews and the fuel shutoff solenoid.

Install the new solenoid in reverse order of removal and connect the wires.

Torque Value: 10 N•m [89 in-lb]

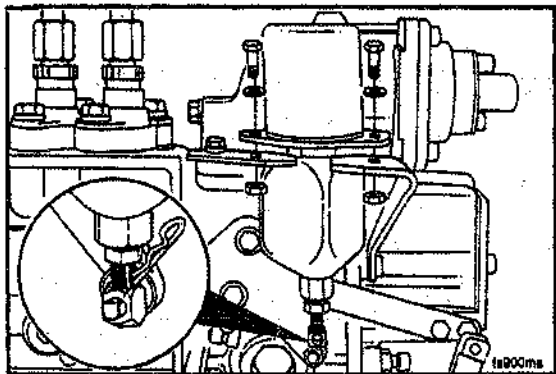

Section A-Adjustment, Replacement and Repair B Series

10 mm, 16 mm

Adjust the solenoid linkage as necessary so that the plunger is magnetically held in with the shutoff lever in the absolute full run position. Turn the large hex on the end of the plunger to make adjustments.

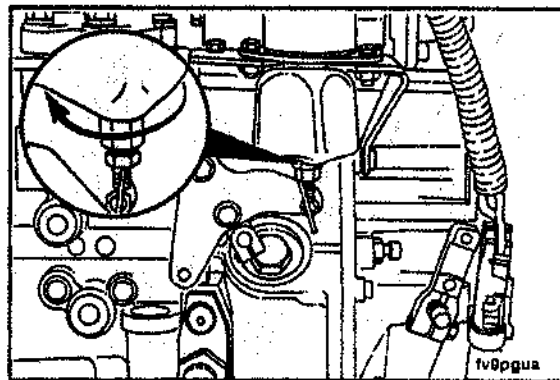

Injection Pump-Replacement

Preparatory Steps:

- Clean debris.
- Remove all fuel lines.
- Remove control linkage.
- Remove fuel shutoff solenoid.
- Remove AFC air line
- Remove oil line(s)

Fuel System Repair-In-Line Pump Page A-70

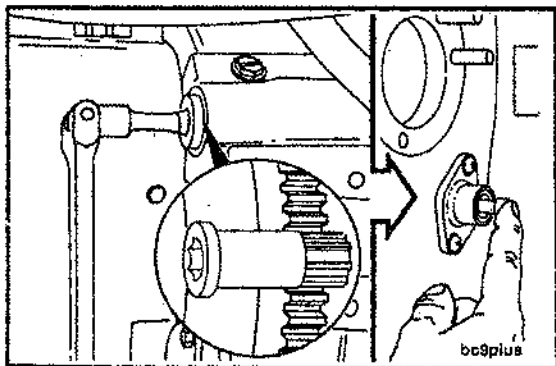
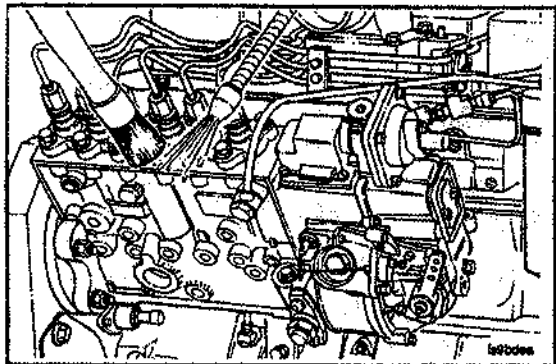

Section A-Adjustment, Replacement and Repair B Series

NOTE: A diesel engine can **not** tolerate dirt or water in the fuel system. A tiny piece of dirt or a few drops of water in the injection system may stop your units.



Clean all external surfaces of the injection pump, including all line connections and fittings that are to be disconnected. Clean the area around the injection pump gear cover to prevent dirt from entering the crankcase.



Injection Pump-Removal

3377371 Engine Barring Gear

Locate TDC for cylinder No. 1. Push the TDC pin into the hole in the camshaft gear while slowly barring the engine.

NOTE: Be sure to disengage the pin after locating TDC.

**Section A-Adjustment, Replacement and Repair
B Series**

10 mm

Remove the fuel pump mounting bracket.

**Fuel System Repair-In-Line Pump
Page A-71**

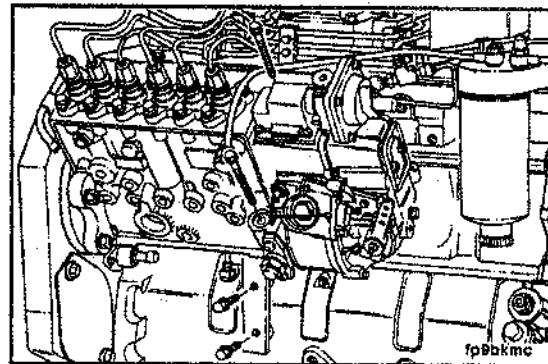

30 mm (P7100 Pump)

Remove the gear cover access cap.

Remove the nut and washer from the fuel pump shaft.

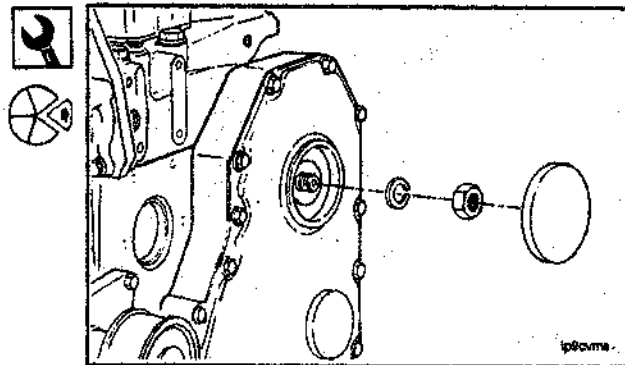

75 mm T-Bar Puller

Pull the fuel pump drive gear loose from the shaft.

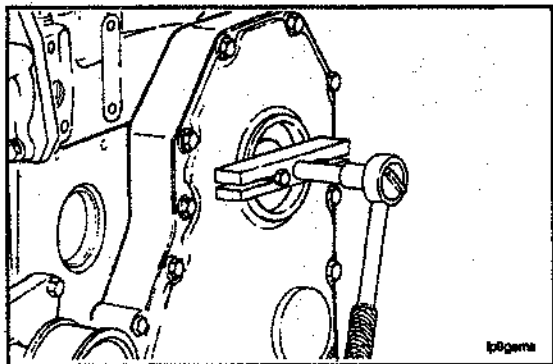

15 mm

Remove the four mounting nuts.

Remove the fuel pump.

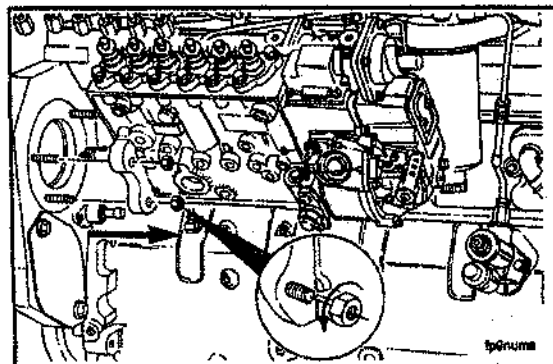

**Section A-Adjustment, Replacement and Repair
B Series**

Injection Pump-Installation

3377371 Engine Barring Gear

Make sure the engine has cylinder No. 1 at TDC.

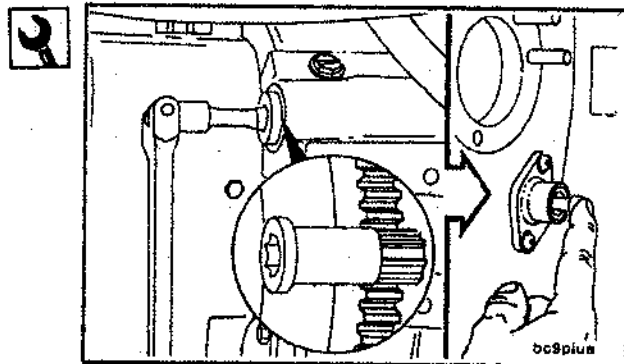

Injection Pump-Timing

The injection pump also has a timing pin, located in the governor housing, to position the pump shaft to correspond with TDC for cylinder No. 1.

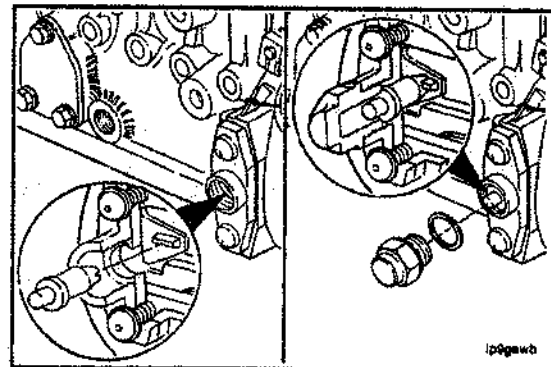

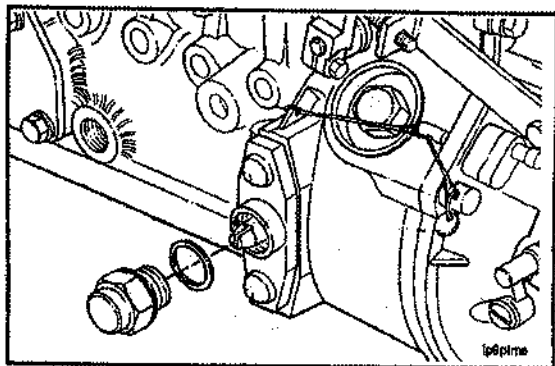

24 mm

Remove the access plug.

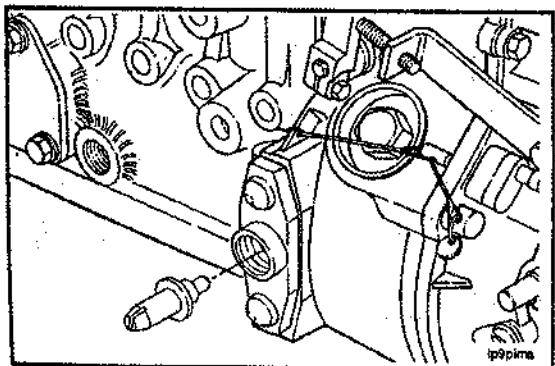

Remove the timing pin.

Section A-Adjustment, Replacement and Repair B Series

If the timing tooth is **not** aligned with the timing pin hole, rotate the pump shaft until the timing tooth aligns.

Reverse the position of the pin so the slot of the pin will fit over the timing tooth in the pump.

Install and secure the pin with the access plug.

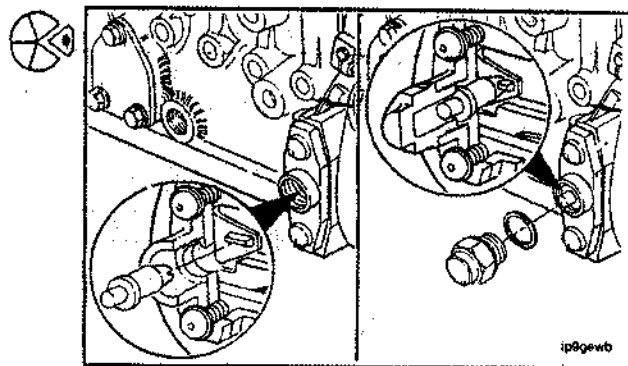
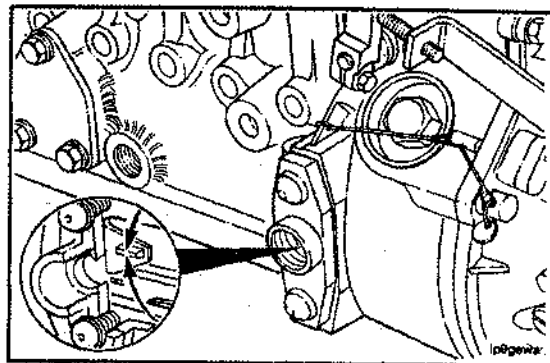

Section A-Adjustment, Replacement and Repair
B Series

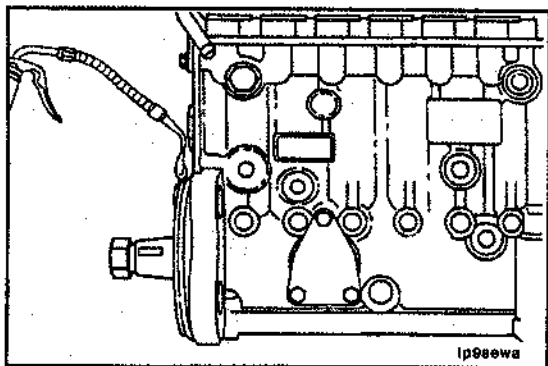

Lubricate the mounting flange of the fuel injection pump with clean engine oil.



Caution: The fuel pump drive gear inside diameter and the shaft outside diameter must be clean and dry before installing the shaft into the gear.

NOTE: The P7100 fuel injection pump driveshaft has a provision for a Woodruff key, however, it is not required. Timing mark alignment is not required for the P7100 drive gear.

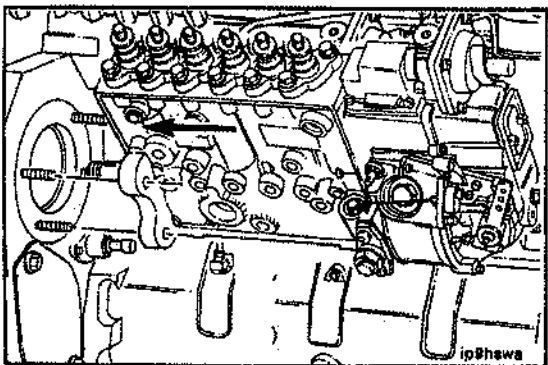

Slide the pump shaft through the drive gear and position the pump flange onto the mounting studs.

Push the pump forward until the mounting flange and o-ring are properly fitted into the gear housing bore.

Section A-Adjustment, Replacement and Repair
B Series

15 mm

Install the mounting nuts.

Torque Value: 43 N·m [32 ft-lb]

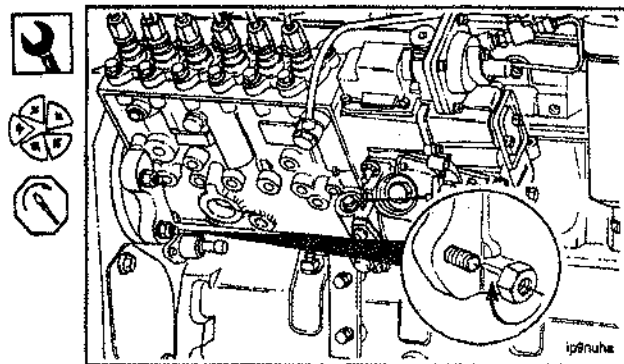

30 mm (P7100 Pump)

Install the retaining nut and washer.

Torque Value: 10 to 15 N·m [7 to 11 ft-lb]

NOTE: Do not exceed the torque value given. This is not the final torque value for the retaining nut.

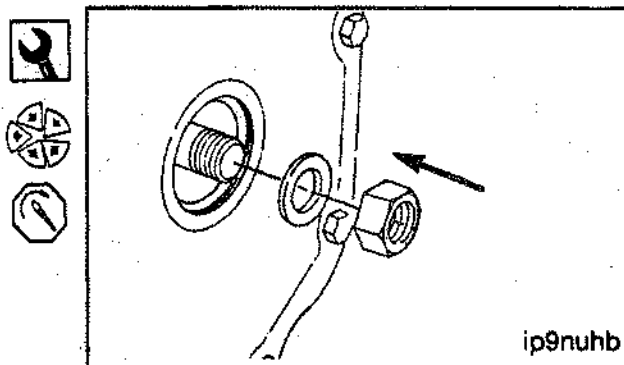

Disengage the engine timing pin.

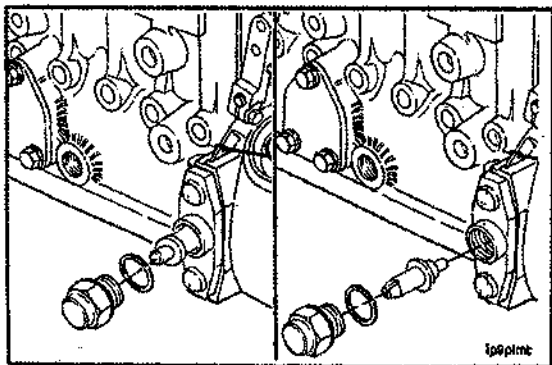
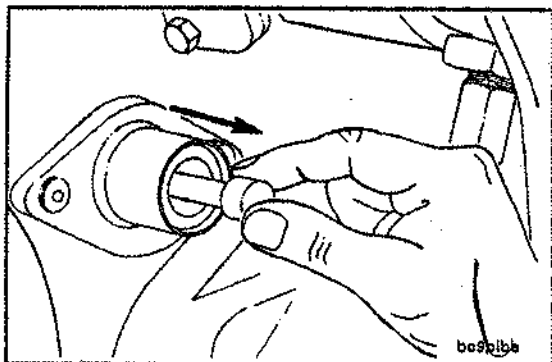

24 mm

Remove the fuel pump timing pin plug. Reverse the position of the pin and install the pin, plug, and sealing washer.

Torque Value: 15 N·m [11 ft-lb]



Section A-Adjustment, Replacement and Repair B Series

22 mm or 27 mm

Tighten the fuel pump drive nut.

Torque Value:

P7100 Pump, 165 N·m [122 ft-lb]

Install the gear cover access cap hand tight.

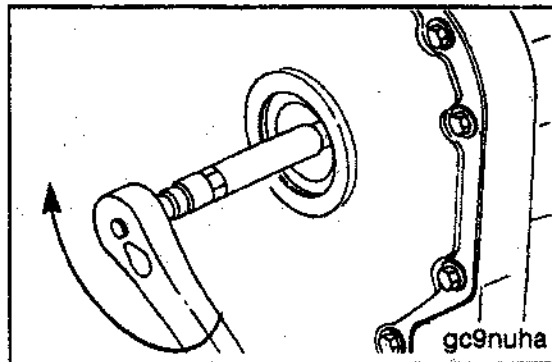

10 mm

Install the fuel pump mounting bracket capscrews finger tight.

To make sure the alignment is correct, tighten the support mounting capscrews.

Torque Value: 24 N·m [18 ft-lb]

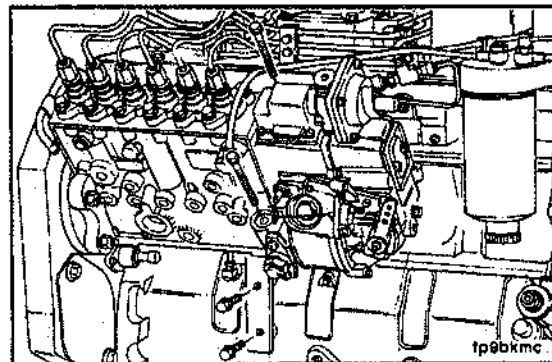

Injection Pump-Idle speed Adjustment

Page A-80

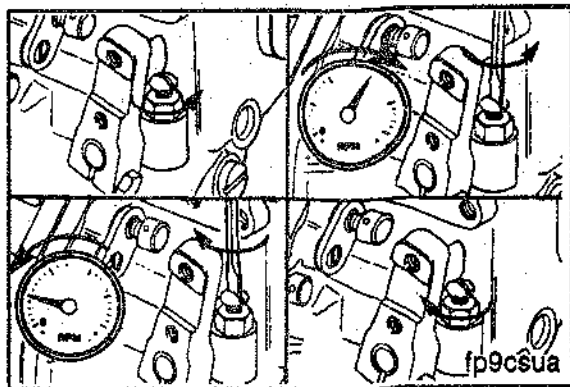
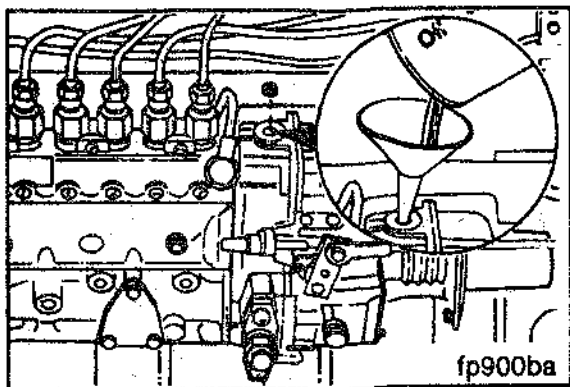

Section A-Adjustment, Replacement and Repair B Series

10 mm Hex Drive



Caution: If a replacement or repaired pump was installed, be sure to fill the governor housing with engine oil before starting the engine. Failure to do so will result in damage to the governor fly weights.

Remove the access plug.

Oil Capacity

Oil Capacity	
RQVK Governor	750 ML [0.71 Qt]

Install the access plug.

Torque Value: 28 N•m [21 ft-lb]

Injection Pump-Idle Speed Adjustment

RQVK Governor



10 mm Screwdriver and Tachometer

Idle adjustment on automotive pumps requires setting of the stop screw.

Loosen the locknut and turn the screw counterclockwise to raise the RPM; clockwise to decrease the idle speed. Tighten the lock screw.

Air System Repair Summary

Component To Be Replaced	Tools	Preparatory Steps*
Air Crossover Tubing	8 mm and Common Screwdriver and Torque Wrench	
Intake Manifold Cover and Gasket	10 mm Socket	Remove high pressure fuel lines, disconnect cold starting aid, if used, and air crossover tubing.
Aftercooler and Gasket	8 mm, 10 mm Socket	Disconnect Cold Starting aid if used, remove air crossover tube and drain coolant.
Turbocharger and/or Gasket	10 mm, 15 mm, 16 mm, 7/16-Inch Wrenches	Disconnect intake and exhaust piping and remove crossover tubing.
Exhaust Manifold and/or Gasket	15 mm Socket	Disconnect intake and exhaust piping, remove air crossover tube and remove the turbocharger.

*Removal of some chassis parts may be necessary to gain access to some engine components. Follow the equipment manufacturer's procedures and precautions for removing chassis parts.

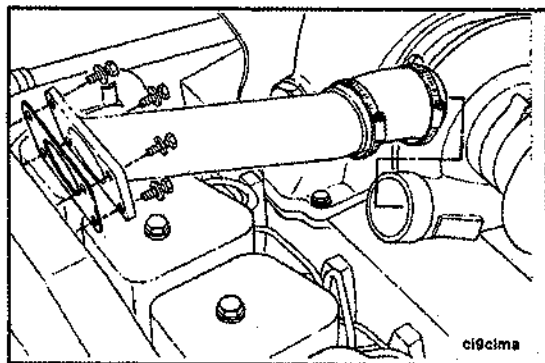

Air System Repair

Air Crossover Tube-Replacement



8 mm or Screwdriver

Loosen the hose clamps and position the hose so the crossover tube can be removed.

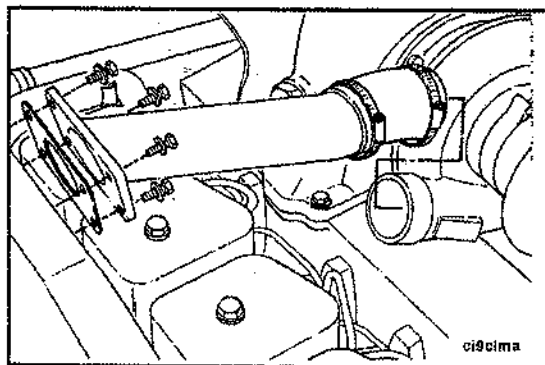

8 mm or Screwdriver

Use new hose and clamps as required to install the crossover tube.



Torque Value: 8 N · m [6 ft-lb]



**Section A-Adjustment, Replacement and Repair
B Series**

**Intake Manifold Cover and Gasket-Replace-
ment**

Preparatory Steps:

- Remove the high pressure fuel lines.
- Disconnect the cold starting aid,if used.
- Remove the air crossover tube(Industrial).

10 mm

Remove the manifold cover and gasket.

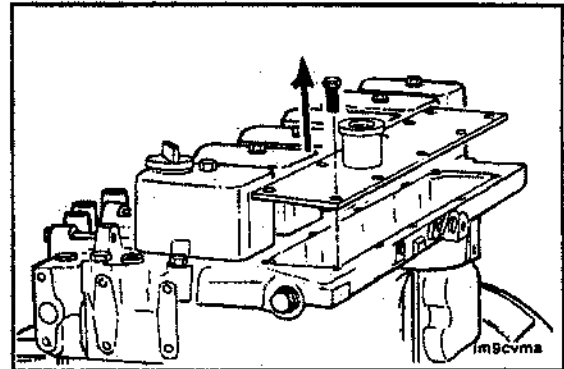

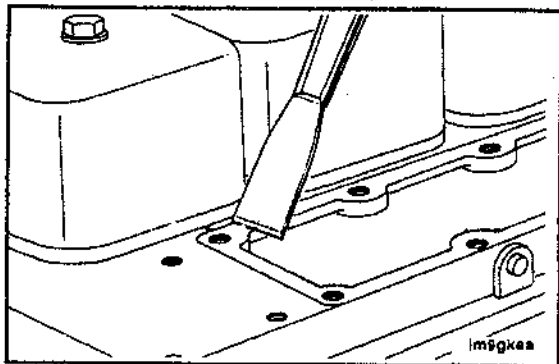

Clean the sealing surface.

NOTE: Keep the gasket material and any other material out of the air intake.

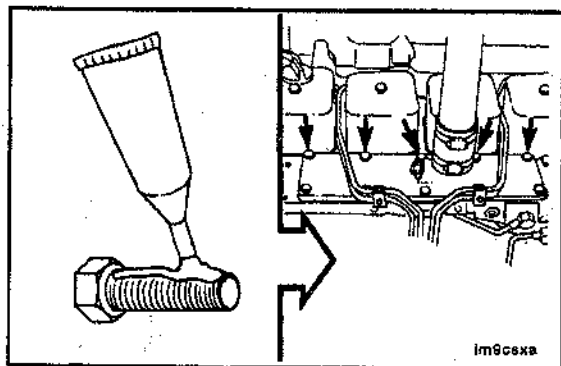

NOTE: The holes shown in the illustration are drilled through and must be sealed by applying liquid teflon sealant to the cap screws.

**Section A-Adjustment, Replacement and Repair
B Series**

10 mm

Install the cover and a new gasket.

Torque Value: 24 N•m [18 ft-lb]

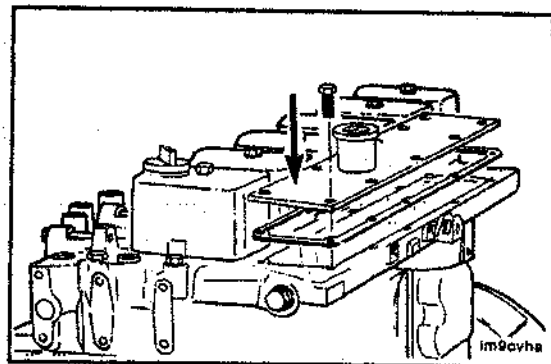

Assemble the intake piping and connect the cold starting aid if used.

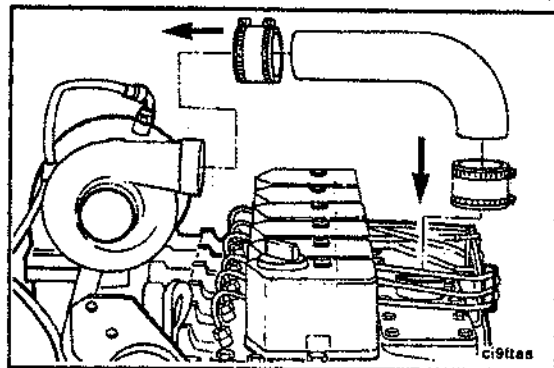

Install and bleed the high pressure fuel lines.

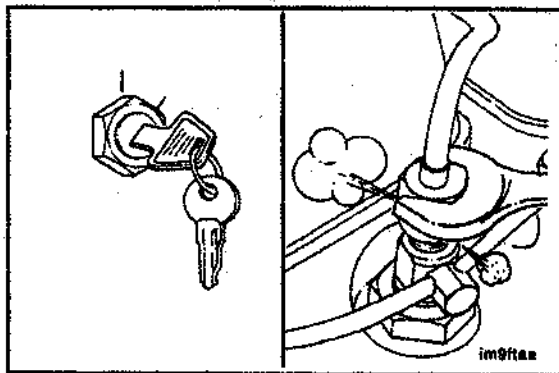

Jacket-Water Aftercooler and Gasket- Replacemet

Preparatory Steps:

- Disconnect the cold starting aid , if used.
- Remove the air crossover tube.
- Remove high pressure fuel lines.
- Drain 2 liters (2.1 U.S. Quarts) of coolant.

Section A-Adjustment, Replacement and Repair
B Series

8 mm

Remove the coolant supply tube (1) and the coolant return tube (2).

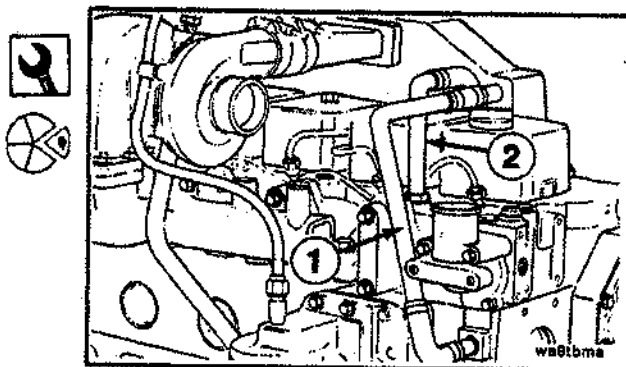

Remove the high pressure fuel lines (reference page 10-25).

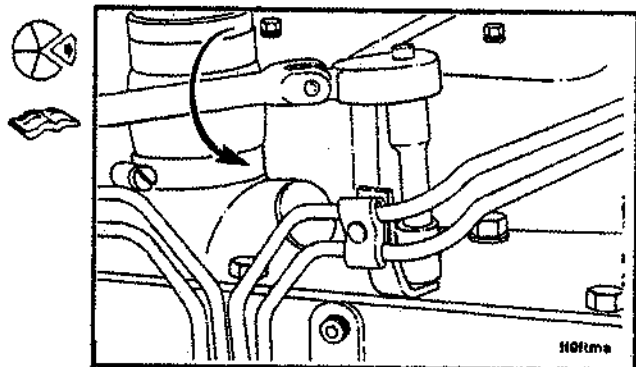

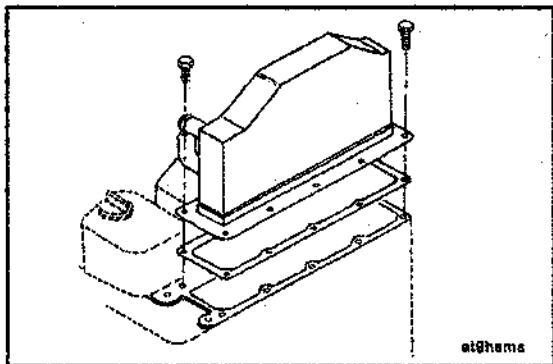

10 mm

Remove the aftercooler housing and gasket.

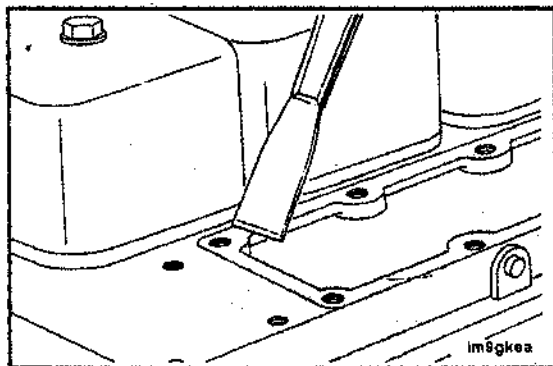

Clean the sealing surface.

NOTE: Keep the gasket material and any other material out of the air intake.

Section A-Adjustment, Replacement and Repair
B Series

10 mm

NOTE: The holes shown in the illustration are drilled through. Apply liquid teflon sealant to the capscrews.

Install the aftercooler housing and a new gasket.

Torque Value: 24 N·m [18 ft-lb]

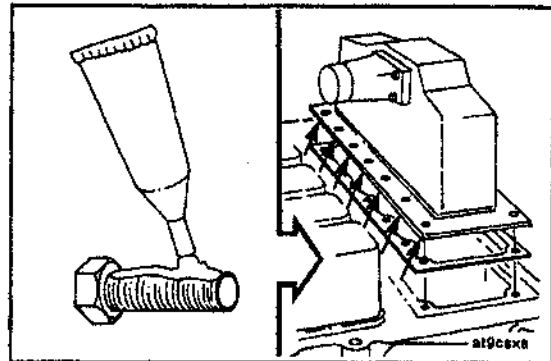

8 mm

Install the coolant supply tube (1) and coolant return tube (2). Install the air crossover tube (3).

Reinstall and bleed the high pressure fuel lines.

Torque Value: 8 N·m [6 ft-lb]

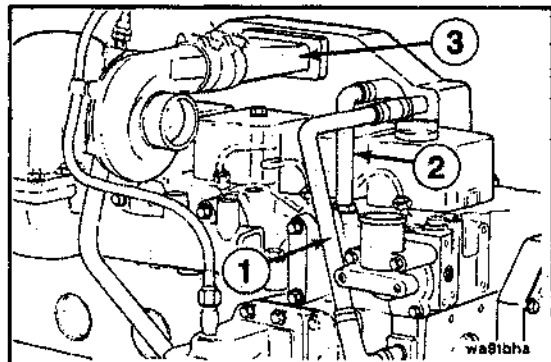

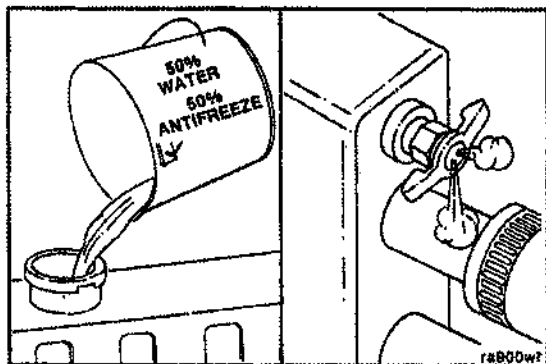

Caution: The system must be filled slowly to prevent air locks. Be sure to open the engine and aftercooler vents to allow air to escape as the system is filled.

Fill the coolant system with a mixture of 50% water and 50% ethylene-glycol type antifreeze.

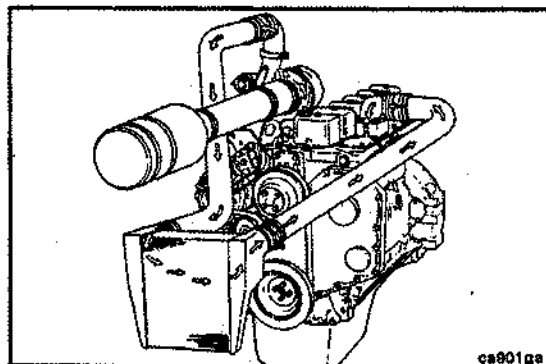

Charge Air Cooler-Leak Check

NOTE: The long term integrity of the charge air cooler system is the responsibility of the vehicle and component manufacturers; however, the following symptoms can be checked by any Cummins Authorized Repair Location:

Section A-Adjustment, Replacement and Repair B Series

Intake Manifold Pressure-Check

Install pressure gauge, Part No. ST-1273, to the fitting in the turbocharger outlet.

Install another pressure gauge, Part No. ST-1273, in the intake manifold.

Operate the engine at rated RPM and load. Record the readings on the two gauges.

If the differential pressure is greater than 21 kPa [3 psi], check the charge air cooler for plugging. Clean or replace if necessary.

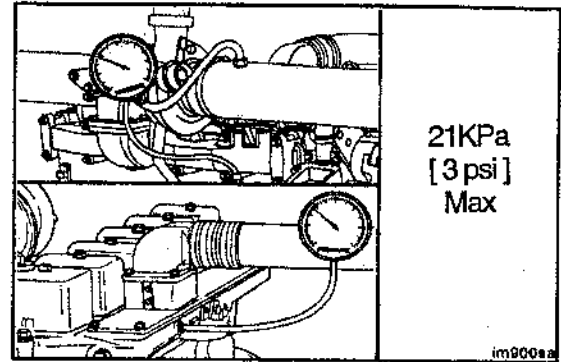

Intake Manifold Temperature-Check

Install a temperature gauge in the intake manifold.

Lock the fan drive in the ON mode to prevent erratic test results. This can be done by installing a jumper across the temperature switch or supplying shop air to the fan. Refer to the fan drive manufacturer for lock-up procedure.

NOTE: Some trucks have a manual switch that will lock on the fan.

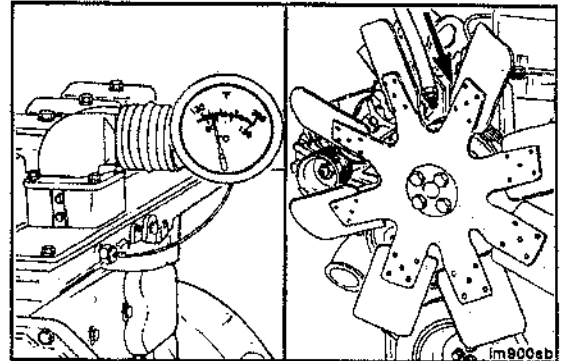

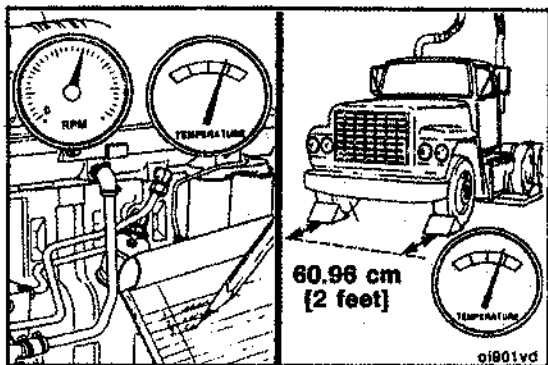

Operate the engine at rated RPM and load. Record the intake manifold temperature.



Measure the ambient temperature at least two feet in front of the vehicle.

The maximum temperature differential **must not** be greater than 25°C [45°F]

If the temperature differential is greater than 25°C [45°F] check the charge air cooler for dirt and debris on the fins, and clean as necessary. If the problem still exists, check the cooler for internal contamination or plugging.

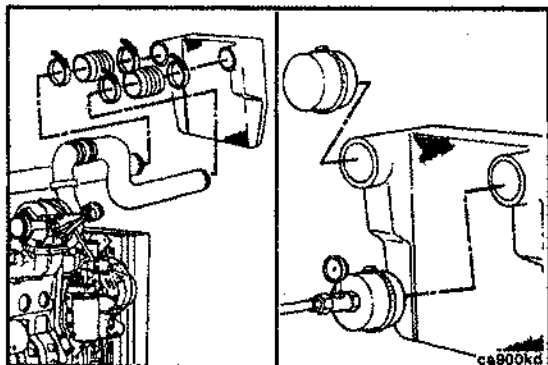

To check the charge air cooler or cracked tubes or header, remove the inlet and outlet hoses from the cooler.

Remove the charge air cooler.

Install a cap over the outlet side of the cooler. Install a pressure gauge and a shop air supply line to the inlet side of the cooler.

Section A-Adjustment, Replacement and Repair B Series

Apply 276 kPa [40 psi] of air pressure to the cooler. If the pressure drop is 35 kPa [5 psi] or less in 15 seconds, the cooler is okay.

If the pressure drop is greater than 35 kPa [5 psi] in 15 seconds, the charge air cooler **must** be repaired or replaced. Refer to the CAC manufacturer for repair instructions.

NOTE: A leak tank can be used to locate the air leak.

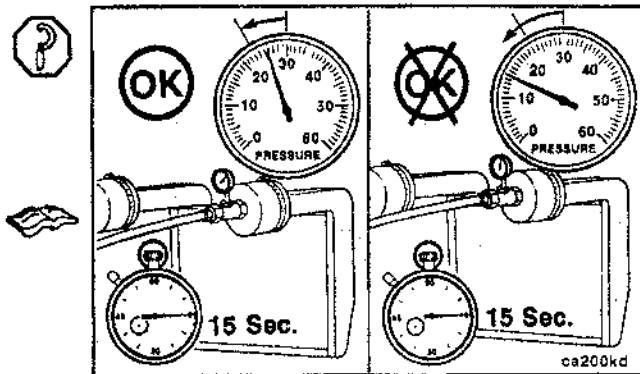

Turbocharger-Replacement

Preparatory Steps:

- Remove the air crossover tube.
- Disconnect the intake and exhaust piping.

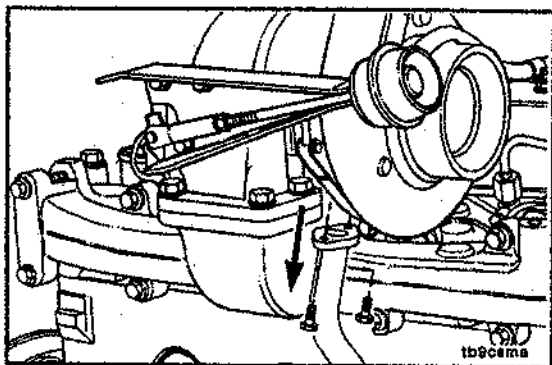

10 mm

Remove the capscrews from the oil drain tube.

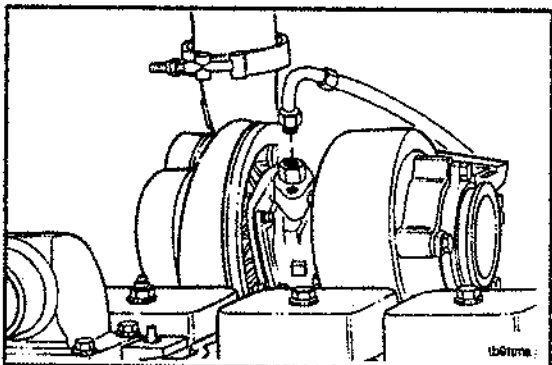

16 mm

Remove the oil supply line.



**Section A-Adjustment, Replacement and Repair
B Series**

If equipped with a wastegate turbocharger, remove the intake manifold pressure supply line from the boost capsule.

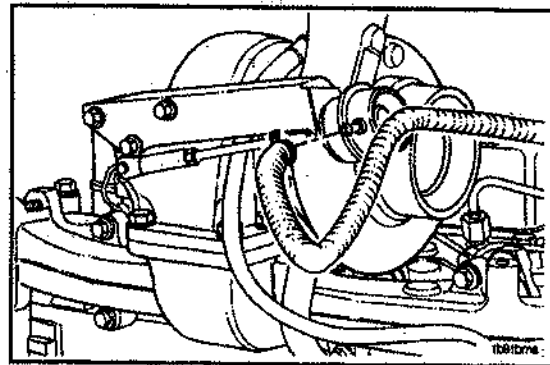

15 mm and 11 mm

Remove the exhaust clamp, turbocharger, and gasket.

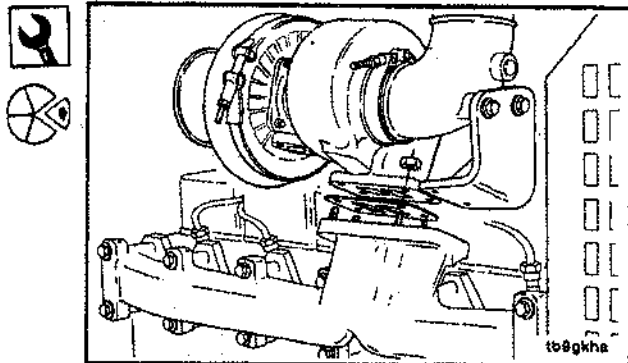

Section A-Adjustment, Replacement and Repair
B Series

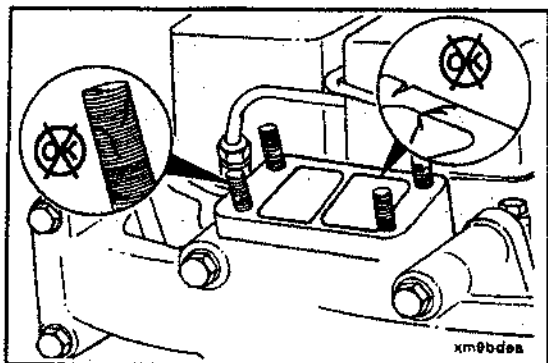

Clean the sealing surface. Inspect the sealing surface and mounting studs for damage.

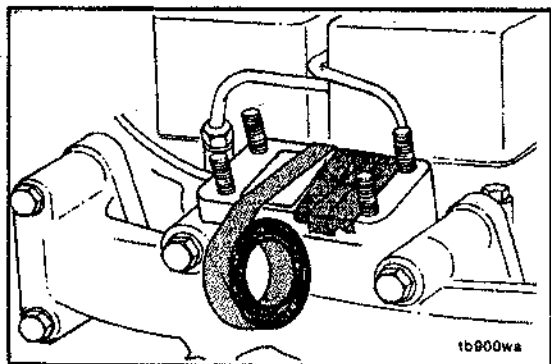

NOTE: If the turbocharger is not to be immediately replaced, cover the opening to prevent any material from falling into the manifold.

Section A-Adjustment, Replacement and Repair

B Series

Install a new gasket and apply anti-seize compound to the mounting studs.



15 mm

Install the turbocharger and a new gasket.

Torque Value: 32 N·m [24 ft-lb]

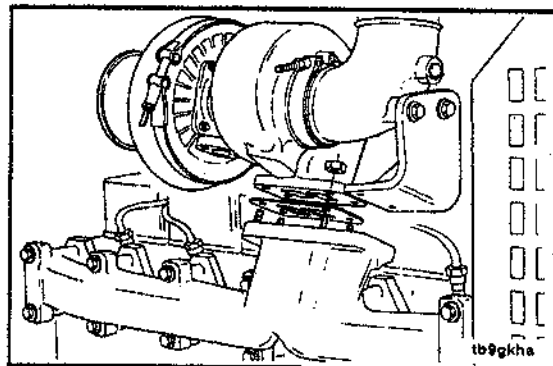
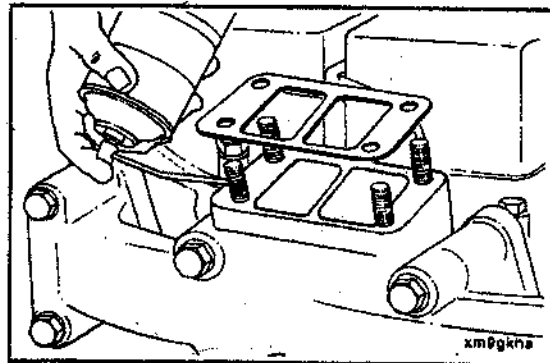

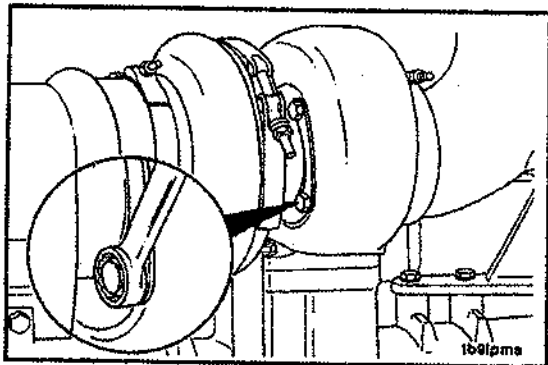

13 mm



If required, bend the lockplates back and loosen the turbine housing capscrews and position the bearing housing to install the turbocharger drain tube.

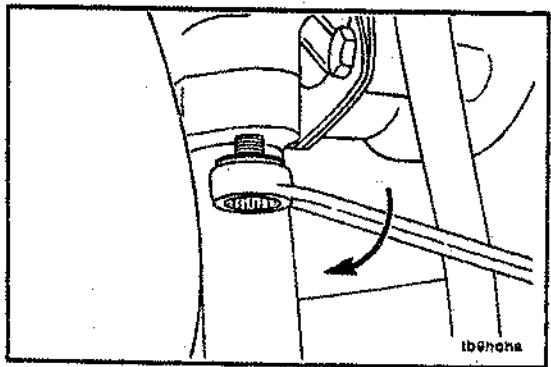

13 mm



Install the hose and clamps on the turbocharger drain tube loosely. Install the drain tube and gasket on the turbocharger.



Torque Value: 24 N·m [18 ft-lb]

Section A-Adjustment, Replacement and Repair

B Series

Screwdriver

Position the turbocharger drain hose to connect the drain tubes; tighten the clamps.

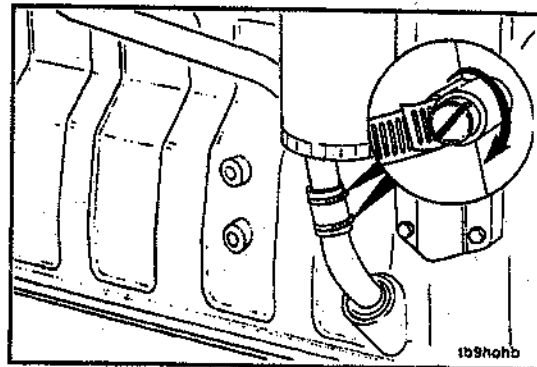

13 mm, Punch, Hammer

If loosened, tighten the turbine housing capscrews. Bend the lockplates onto the flats to prevent loosening.

Torque Value: 11.3 N·m [8 ft-lb]

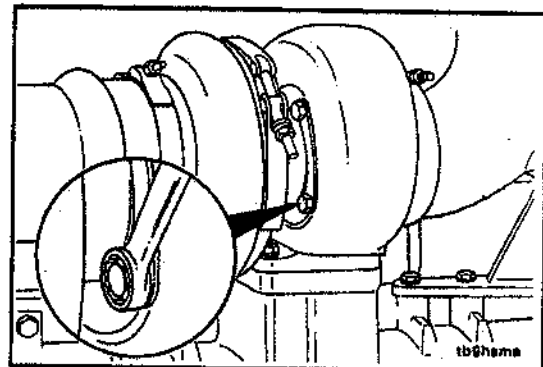

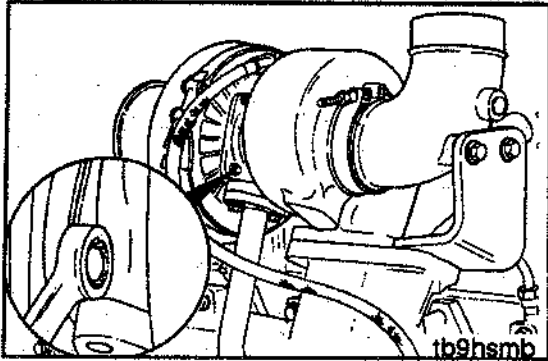

10 mm

If required, loosen the compressor housing and position the housing to align with the crossover tube.



Torque Value: 5.7 N•m [50 in-lb]

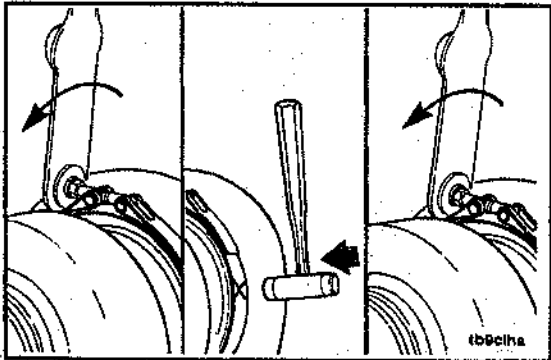

11 mm, plastic Hammer

Tighten the band clamp to 5.7 N•m [50 in-lb]. Tap around the clamp with a plastic hammer and tighten again to 5.7 N•m [50 in-lb].



Section A-Adjustment, Replacement and Repair
B Series

Caution: To prevent bearing damage new turbochargers must be prelubricated before start-up.



Pour 50 to 60 [2 to 3 ounces] of clean engine oil into the oil supply fitting. Rotate the turbine wheel to allow the oil to enter the bearing housing.

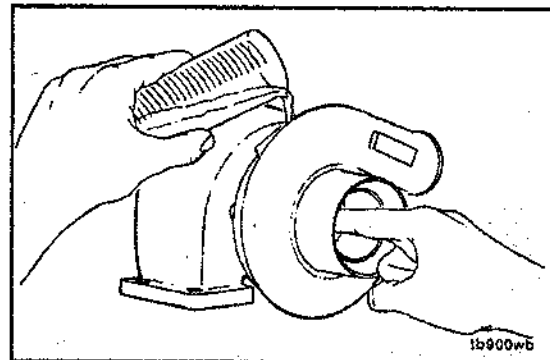

Install the exhaust outlet connection.

Do not tighten the two mounting capscrews until the band clamp has been tightened.

Torque Value: Band Clamp-8 N·m [6 ft-lb]
Capscrews - 43 N·m [32 ft-lb]

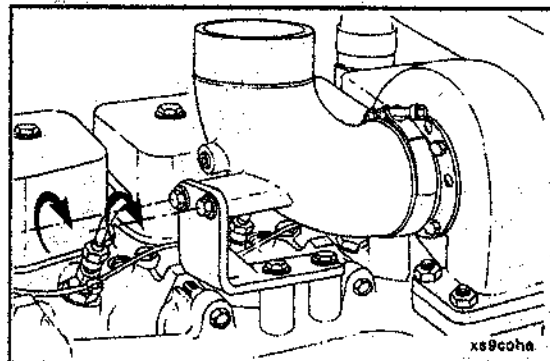

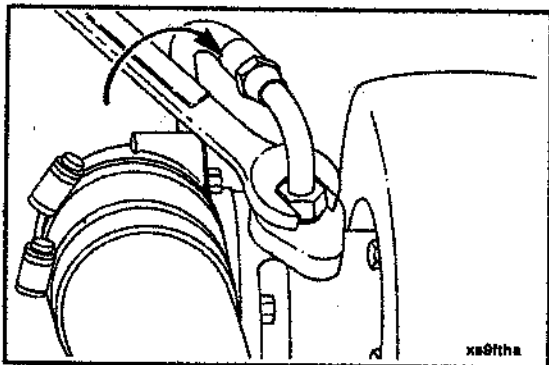

16 mm

Install the oil supply line.



Torque Value: 15 N·m [11 ft-lb]

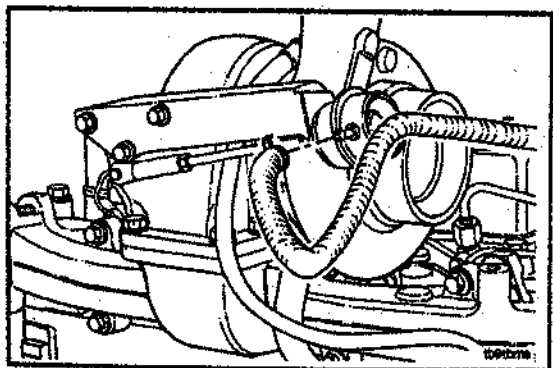

If equipped with a wastegate turbocharger, install the intake manifold pressure supply line from the boost capsule.

Section A-Adjustment, Replacement and Repair

B Series

Install the air crossover tube, inlet and exhaust piping.
Operate the engine and check for leaks.

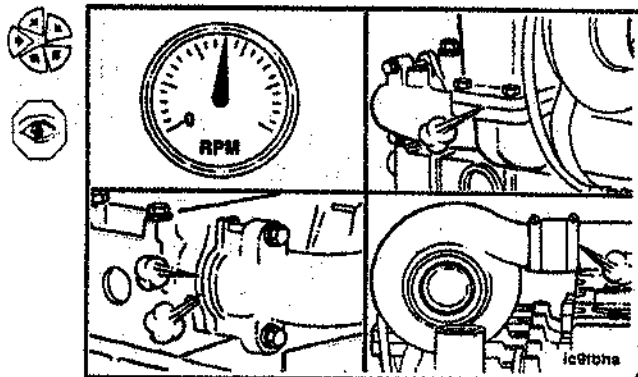

Exhaust Manifold and Gaskets -Replacement

Preparatory Steps:

- Remove the air crossover tube.
- Disconnect the air intake and exhaust piping.
- Remove the turbocharger, if used.

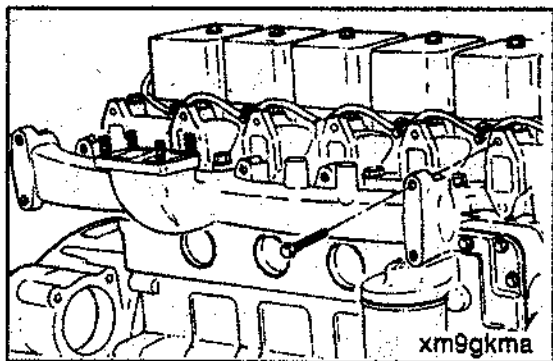

15 mm

Remove the exhaust manifold and gaskets.

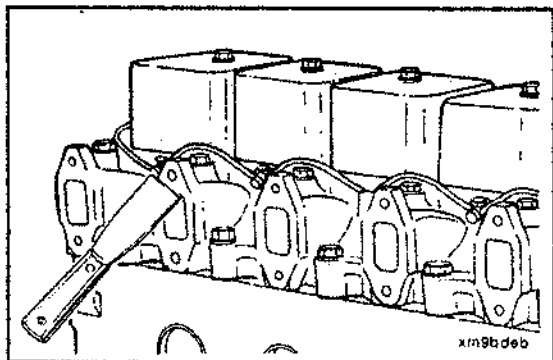

Clean the sealing surfaces.

Section A-Adjustment, Replacement and Repair
B Series

15 mm

Install the exhaust manifold and new gaskets.

Torque Value: 43 N·m [32 ft-lb]

Follow the tightening sequence shown in the illustration. Then, follow the same sequence and tighten the capscrews again to the same torque values.

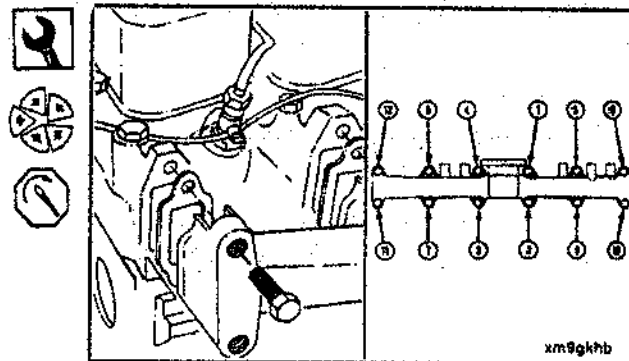

Install the parts previously removed. Operate the engine and check for leaks.

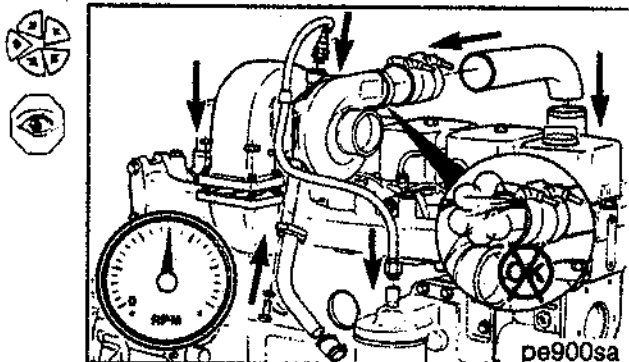

Lubricating System Repair Summary

Component To Be Replaced	Tools	Preparatory Steps
Oil Pressure Regulator Valve and/or Spring	Ratchet, 22 mm Socket and Torque Wrench.	Clean debris.
Oil Cooler Element and/or Gaskets	16 mm Wrench, Ratchet, 10 mm Socket and Torque Wrench.	Drain Coolant. Remove the oil filter.

Lubricating System Repair

Oil Pressure Regulator, Valve and Spring Replacement.

Preparatory Steps:

- Clean debris.

22 mm

Remove the plug and regulator valve.

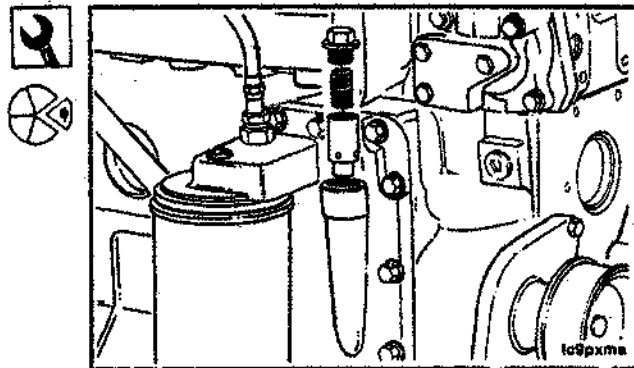

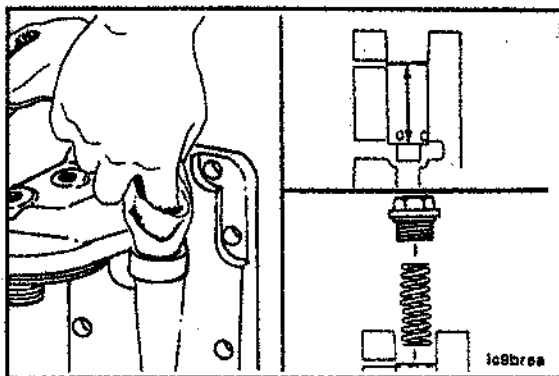

22 mm



Clean and inspect the bore and regulator valve before assembly.



Caution: In order to regulate the oil pressure, the valve must move freely in the bore.



Install the regulator and spring.



Torque Value: 80 N·m [60 ft-lb]



Oil Cooler Element and Gasket-Replacement

Preparatory Steps:

- Drain The coolant.
- Remove the oil filter.

Section A-Adjustment, Replacement and Repair
B Series

Clean all debris from around the oil cooler.

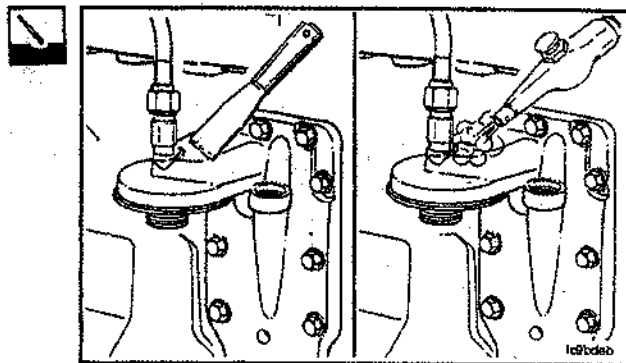

16 mm

Remove the turbocharger oil supply line from the oil filter head.

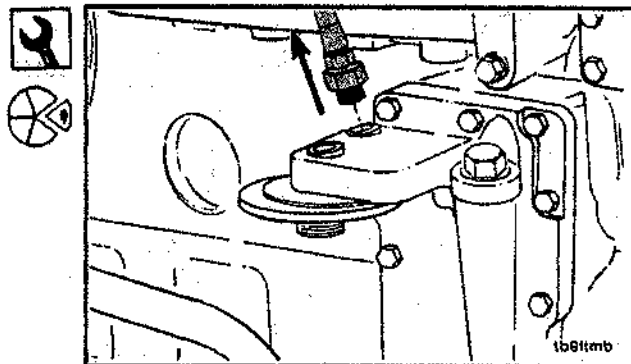

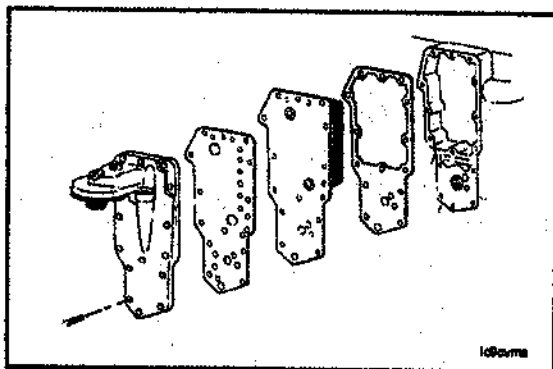

10 mm

Remove the oil cooler cover, element and gaskets.

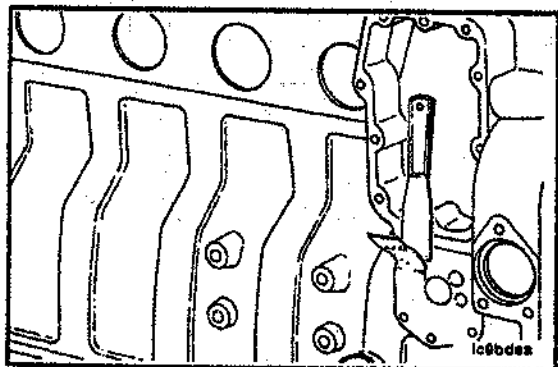

Clean the sealing surfaces.

Section A-Adjustment, Replacement and Repair

B Series

Pressurize the element to 690 kPa [100 psi] to check it for leaks.

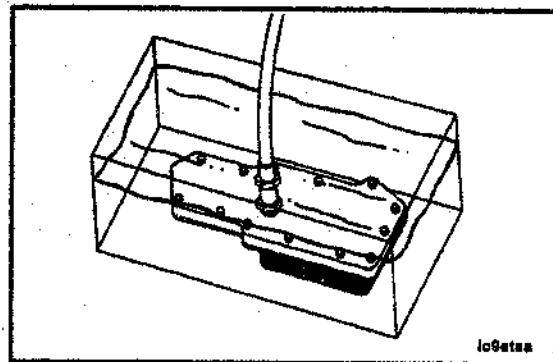

10 mm

Assemble the oil cooler gasket, element, cooler cover gasket and cooler cover to the cylinder block.

NOTE: Be sure to remove the shipping plugs (A) from the new cooler element.

Torque Value: 24 N•m [18 ft•lb]

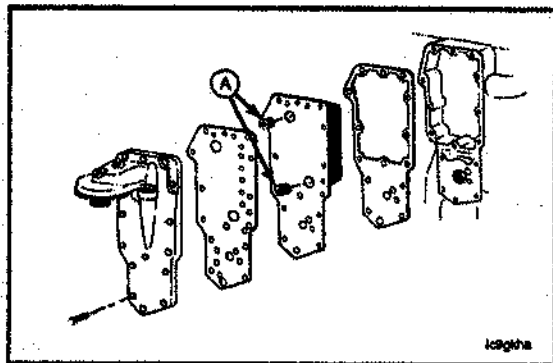

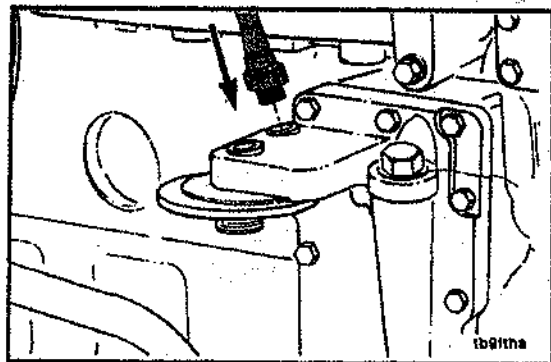

16 mm

Connect the turbocharger oil supply line.

Torque Value: 15 N·m [11 ft-lb]

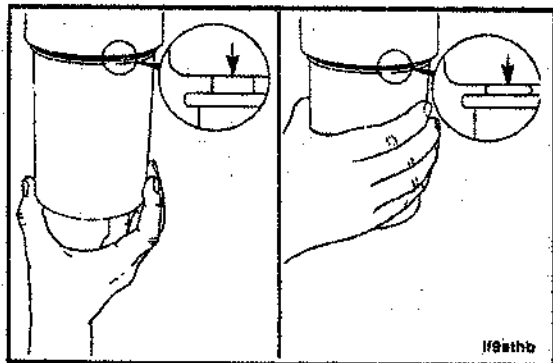

Install a new oil filter.

Follow the manufacturer's instructions for tightening.

Section A-Adjustment, Replacement and Repair
B Series

Caution: The system must be filled slowly to prevent air locks. Be sure to open the aftercooler vents to allow air to escape as the system is filled.

Fill the coolant system and operate the engine to check for leaks.

Stop the engine and check the coolant and oil level.

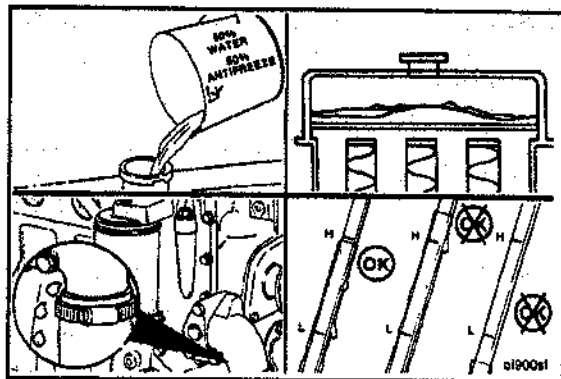

Electrical System Repair Summary

Component To Be Replaced	Tools	Preparatory steps
Starting Motor	Ratchet, 17 mm Socket, 14 mm Wrench, and Torque Wrench	Disconnect ground cable to battery.
Alternator	Ratchet, 8 mm, 14 mm and 16 mm Socket and torque Wrench, 1/2 inch Square Drive Breaker Bar	Disconnect ground cable to battery and remove drive belt.

Electrical System Repair

Starting Motor-Replacement

Disconnect the ground cable from the battery.
Identify each electrical wire with a tag indicating location.

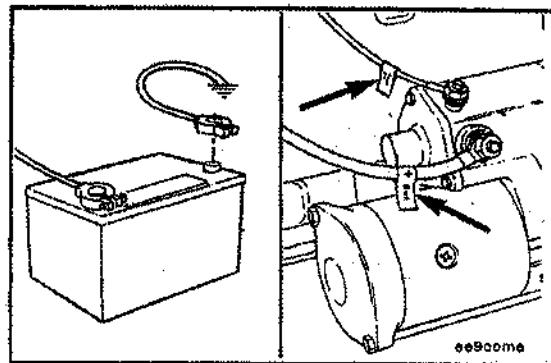

14 mm

Remove the battery cable from the solenoid.

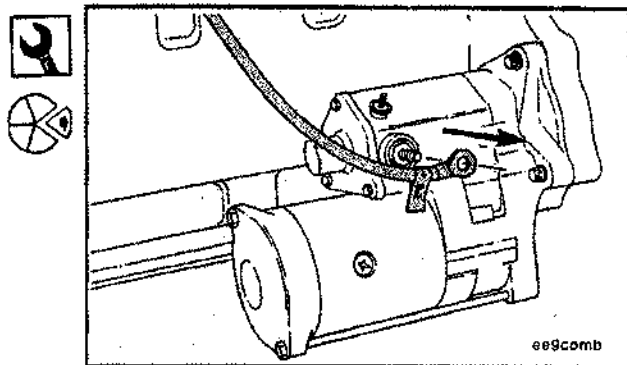

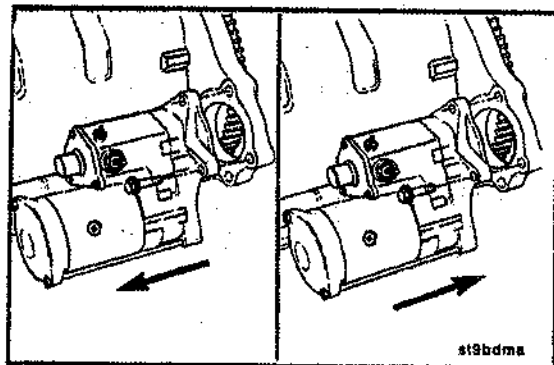

10 mm

Remove the starting motor.



Install the starting motor in the reverse order of removal.



Torque Value: 43 N·m [32 ft·lb]

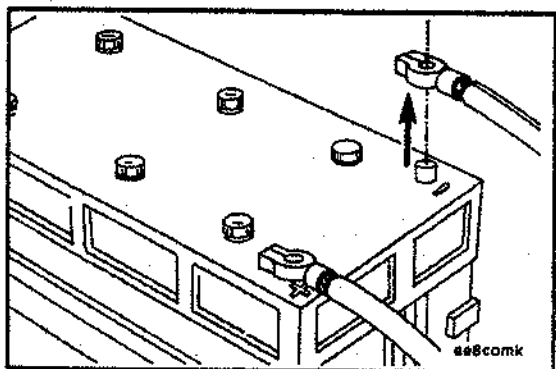

Alternator-Replacement

Disconnect the ground cable from the battery terminal.
Identify each electrical wire with a tag indicating location.
Remove the drive belt.

Section A-Adjustment, Replacement and Repair
B Series

14 mm

Remove the capscrew from the alternator link.

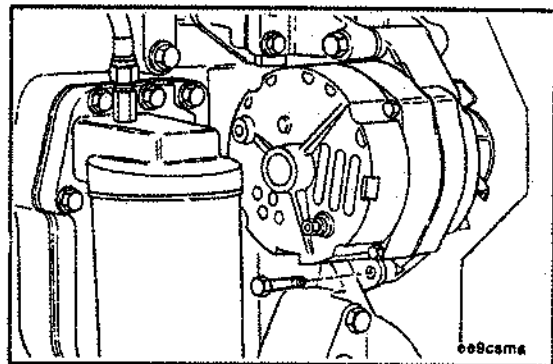

16 mm

Remove the alternator mounting capscrews.
Remove the alternator.

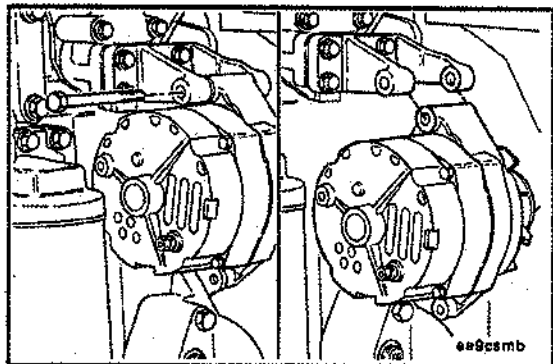

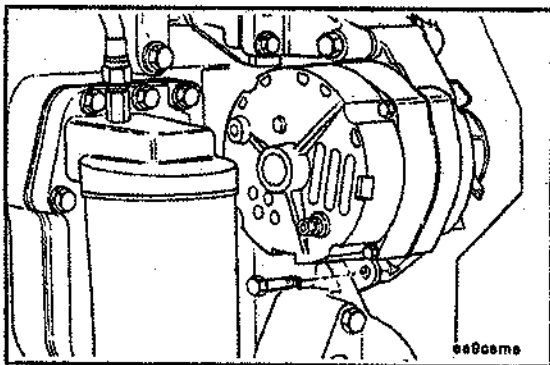

Position the alternator on the bracket and secure it with the mounting capscrews.

Do not tighten at this time.

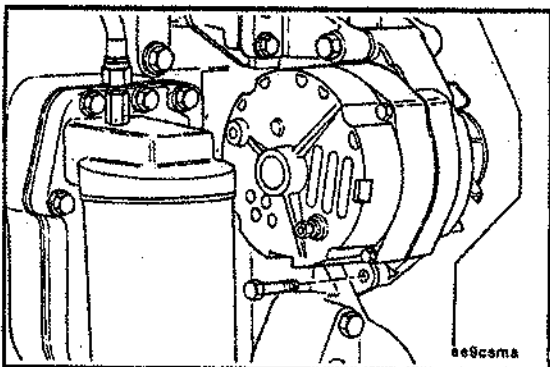

Connect the alternator link to the alternator. Finger tighten.

NOTE: Make sure the alternator link is properly positioned for correct belt alignment.

Section A-Adjustment, Replacement and Repair

B Series

14,16 mm

Tighten the alternator mounting capscrew.

Torque Value:

A = 24 N·m [18 ft-lb]

A = 43 N·m [32 ft-lb]

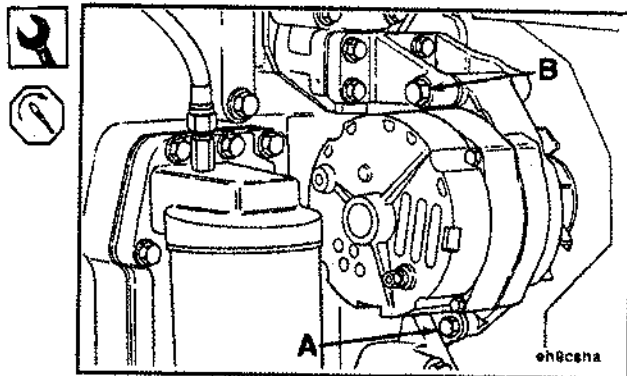

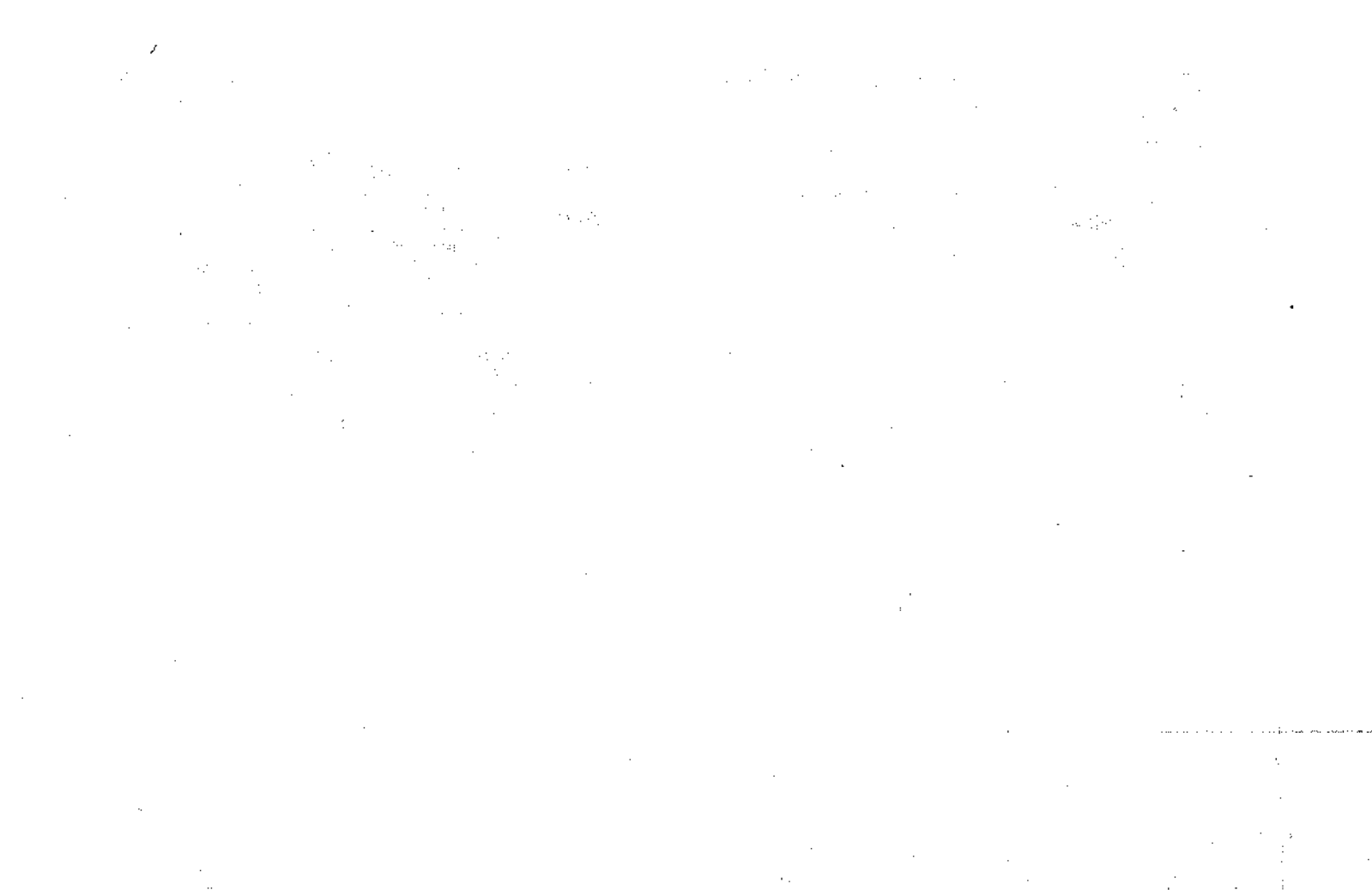

Section V-Specifications and Torque Values

Section contents

	Page
Arctic Operation	V-15
Capscrew Markings and Torque values	V-22
Capscrew Markings and Torque Values-Metric.....	V-23
Capscrew Markings and Torque Values-U. S. Customary.....	V-24
Coolant Recommendations/Specifications	V-16
Engine Component Torque Value	V-18, V-19, V-20
Engine Specifications(Non-Automotive Engines)	V-2
Batteries(Specific Gravity).....	V-5
Filter Selection	V-17
Fuel Filters.....	V-17
Oil Filters.....	V-17
Fuel Recommendations/Specifications	V-10
General Specifications (Automotive Engines)	V-6, V-7, V-8, V-9
Lubricating Oil Recommendations/Specifications	V-12
New Engine Break-In Oils.....	V-13
Oil Performance Recommendations.....	V-12
Oil Viscosity Recommendations.....	V-12
Sealants	V-21

Engine Specifications (Non-Automotive Engines)

GENERAL ENGINE DATA	4B3.9	4BT3.9	4BTA3.9	6B5.9	6BT5.9	6BTA5.9
Bore-mm [in.].....	102 [4.02]					
Stroke-mm [in.].....	120 [4.72]					
Displacement-liter [in. ³]	3.9 [239]			5.9 [359]		
Engine Weight (Dry) Less Fly-wheel and Electrics-Kg [lbs.].....	308 [680]	320 [705]	329 [725]	388 [855]	399 [880]	411 [905]
Firing Order.....	1.3.4.2.			1.5.3.6.2.4.		
Valve Clearances						
-intake-mm [in.].....	0.25 [0.010]					
-Exhaust-mm [in.].....	0.51 [0.020]					
Compression Ratio.....	18.5 : 1	17.5 : 1	16.5 : 1	18.5 : 1	17.5 : 1	16.5 : 1
Rotation viewed from the Front of the Engine.....	Clockwise					
Aspiration						
-Naturally Aspirated.....	x			x		
-Turbocharged.....		x	x		x	x
-Aftercooled.....			x			x
-Charge Air Cooled.....						

Section V-Specifications and Torque Values
B Series

Engine Specifications (Non-Automotive Engines)
Page V-3

LUBRICATION SYSTEM kPa [psi]	4B3.9	4BT3.9	4BTA3.9*	6B5.9	6BT5.9	6BTA5.9
Minimum Allowable Oil Pressure@ Idle	69 [10]	69 [10]	69 [10]	69 [10]	69 [10]	69 [10]
Minimum Allowable Oil Pressure@ Rated	207 [30]	207 [30]	207 [30]	207 [30]	207 [30]	207 [30]
Regulated Pressure	449 [65]	449 [65]	449 [65]	449 [65]	449 [65]	449 [65]
Differential Pressure to Open Filter Bypass	138 [20]	138 [20]	138 [20]	138 [20]	138 [20]	138 [20]
Oil Capacity L [QT]						
Standard Pan Only	9.5 [10]	9.5 [10]	9.5 [10]	14.2 [15]	14.2 [15]	14.2 [15]
Total System (Pan, Filter, Lines)	10.9[11.5]	11 [11.6]	11 [11.6]	16.3[17.2]	16.4[17.3]	16.4[17.3]
No. QTS From "L" to "H" on Dipstick	[1]	[1]	[1]	[2]	[2]	[2]
COOLING SYSTEM L [QT]						
Engine Coolant Capacity	7.0 [7.4]	7.0 [7.4]	7.9 [8.4]	9.0 [9.5]	9.0 [9.5]	9.9[10.5]
Thermostat Modulating Range°C [°F]	83-95 [181-230]	83-95 [181-203]	83-95 [181-203]	83-95 [181-203]	83-95 [181-203]	83-95 [181-203]
Pressure Cap kPa [psi]						
104°C [220°F]	103 [15]	103 [15]	103 [15]	103 [15]	103 [15]	103 [15]
99°C [210°F]	48 [7]	48 [7]	48 [7]	48 [7]	48 [7]	48 [7]

*Jacket-water aftercooled

INTAKE AIR, EXHAUST AND FUEL SYSTEM	4B3.9	4BT3.9	4BTA3.9	6B5.9	6BT5.9	6BTA5.9
Maximum Allowable Intake Restriction at Rated Speed and Load with Dirty Air Filter Element - mm H ₂ O [in. H ₂ O].....	508 [20]	635 [25]	635 [25]	508 [20]	635 [25]	635 [25]
Maximum Allowable Exhaust Restriction at Rated Speed and Load-mm Hg [in. Hg].....	76.2 mm [3 in.]					
Maximum Allowable Restriction to Transfer Pump-mm Hg [in. Hg].....	100 mm [4 in.]					
Maximum Allowable Return Line Restriction-mm Hg [in. Hg].....	518 mm [20.4 in.]					
Maximum Fuel Pressure Drop Across Filters kPa [psi].....	34 [5]					

Section V-Specifications and Torque Values

Engine Specifications (Non-Automotive Engines)

B Series

Page V-5

ELECTRICAL SYSTEM	4B3.9	4BT3.9	4BTA3.9	6B5.9	6BT5.9	6BTA5.9
Minimum Recommended Battery Capacity-With Light Accessories*						
-12V Starter.....	625CCA	625CCA	8CCA	800CCA	800CCA	800CCA
-24 V Starter.....	312CCA	400CCA	400CCA	400CCA	400CCA	400CCA
With Heavy Accessories**						
-12V Starter.....	800CCA	800CCA	800CCA	950CCA	950CCA	950CCA
-24 V Starter.....	400CCA	400CCA	400CCA	475CCA	475CCA	475CCA
Maximum Allowable Resistance of Starting Circuit						
-With 12 V Starter-Ohms.....				0.0012		
-With 24 V Starter-Ohms.....				0.0020		

*Typical light accessories include alternator, small steering pump, and disengaged clutch.

**Typical heavy accessories include hydraulic pump and torque converter.

Batteries (Specific Gravity)

Specific Gravity at 27 °C [80 °F]	State of Charge
1.260-1.280	100%
1.230-1.250	75%
1.200-1.220	50%
1.170-1.190	25%
1.110-1.130	Discharged

General Specifications (Automotive Engines)

GENERAL ENGINE DATA	B5.9-160	B5.9-175	B5.9-190	B5.9-210	B5.9-230
Bore-mm [in.].....	102 [4.02]	102 [4.02]	102 [4.02]	102 [4.02]	102 [4.02]
Stroke-mm [in.].....	120 [4.72]	120 [4.72]	120 [4.72]	120 [4.72]	120 [4.72]
Displacement-liter [in. ³].....	5.9 [359]	5.9 [359]	5.9 [359]	5.9 [359]	5.9 [359]
Engine Weight (Dry) Less Fly-wheel and Electrics-kg [lbs].....	428 [942]	428 [942]	428 [942]	428 [942]	428 [942]
Firing Order.....	1-5-3-6-2-4	1-5-3-6-2-4	1-5-3-6-2-4	1-5-3-6-2-4	1-5-3-6-2-4
Valve Clearances:					
-Intake-mm [in.].....	0.25 [0.010]	0.25 [0.010]	0.25 [0.010]	0.25 [0.010]	0.25 [0.010]
-Exhaust-mm [in.].....	0.51 [0.020]	0.51 [0.020]	0.51 [0.020]	0.51 [0.020]	0.51 [0.020]
Compression Ratio.....	17.5:1	17.5:1	17.1:1	17.1:1	17.1:1
Rotation, viewed from the Front of the Engine.....	Clockwise	Clockwise	Clockwise	Clockwise	Clockwise
Aspiration:					
-Naturally Aspirated.....					
-Turbocharged.....	×	×	×	×	×
-Aftercooled.....					
-Charge Air Cooled.....	×	×	×	×	×

General Specifications (Automotive Engines)

Lubricating System kPa [psi]	B5.9-160	B5.9-175	B5.9-190	B5.9-210	B5.9-230
Min. Allowable Press. @ Idle.....	69 [10]	69 [10]	69 [10]	69 [10]	69 [10]
Min. Allowable Press. @ Rated.....	207 [30]	207 [30]	207 [30]	207 [30]	207 [30]
Regulated Pressure.....	449 [65]	449 [65]	449 [65]	449 [65]	449 [65]
Filter Bypass Diff. Pressure Oil Capacity L [QT]:	138 [20]	138 [20]	138 [20]	138 [20]	138 [20]
-Standard Pan Only.....	14.2 [15]	14.2 [15]	14.2 [15]	14.2 [15]	14.2 [15]
-Total System.....	16.4 [17.3]	16.4 [17.3]	16.4 [17.3]	16.4 [17.3]	16.4 [17.3]
QTS From "L" to "H".....	[2]	[2]	[2]	[2]	[2]
COOLING SYSTEM L [QT]	B5.9-160	B5.9-180	B5.9-190	B5.9-210	B5.9-230
Engine Coolant Capacity.....	9.0 [9.5]	9.0 [9.5]	9.0 [9.5]	9.0 [9.5]	9.0 [9.5]
Thermostat Modulating Range:					
C.....	83-95	83-95	83-95	83-95	83-95
[F].....	[181-203]	[181-203]	[181-203]	[181-203]	[181-203]
Pressure Cap kPa [psi]:					
-104°C [220°F].....	103 [15]	103 [15]	103 [15]	103 [15]	103 [15]
-99°C [210°F].....	48 [7]	48 [7]	48 [7]	48 [7]	48 [7]

General Specifications (Automotive Engines)

Intake Air, Exhaust, and Fuel System	B5.9-160	B5.9-175	B5.9-190	B5.9-210	B5.9-230
Maximum Allowable Intake Restriction at Rated Speed and Load with Dirty Air Filter Element-mm H ₂ O [in. H ₂ O].....	635 [25]	635 [25]	635 [25]	635 [25]	635 [25]
Maximum Allowable Exhaust Restriction at Rated Speed and Load-mm Hg [in. Hg].....	152.4 [6]	152.4 [6]	152.4 [6]	152.4 [6]	152.4 [6]
Maximum Allowable Restriction to Fuel Transfer Pump-With Dirty Filter-mm Hg [in. Hg].....	100 [4]	100 [4]	100 [4]	100 [4]	100 [4]
Maximum Allowable Return Line Restriction-mm Hg [in. Hg].....	518 [20.4]	518 [20.4]	518 [20.4]	518 [20.4]	518 [20.4]
Maximum Fuel Pressure Drop Across Filters kPa [psi]	----- 34 [5] -----				

General Specifications (Automotive Engines)

Electrical System	B5.9-160	B5.9-175	B5.9-190	B5.9-210	B5.9-230
Minimum Recommended Battery Capacity-With Light Accessories* :					
- 12 V Starter	800CCA	800CCA	800CCA	800CCA	800CCA
- 24 V Starter	400CCA	400CCA	400CCA	400CCA	400CCA
With heavy Accessories**:					
- 12 V Starter	950CCA	950CCA	950CCA	950CCA	950CCA
- 24 V Starter	475CCA	475CCA	475CCA	475CCA	475CCA
Maximum Allowable Resistance of Starting Circuit:					
- With 12 V Starter-Ohms	.0012	.0012	.0012	.0012	.0012
- With 24 V Starter-Ohms	.0012	.0012	.0012	.0012	.0012

*Typical light accessories include alternator, small steering pump, and disengaged clutch.

**Typical heavy accessories include hydraulic pump and torque converter.

1. The first part of the document discusses the importance of maintaining accurate records of all transactions and activities. It emphasizes that this is crucial for ensuring transparency and accountability in the organization's operations.

2. The second part of the document outlines the various methods and tools used to collect and analyze data. It highlights the need for a systematic approach to data collection and the importance of using reliable and valid measurement instruments.

3. The third part of the document discusses the ethical considerations that must be taken into account when conducting research. It emphasizes the need to protect the privacy and confidentiality of participants and to obtain their informed consent before any data collection begins.

4. The fourth part of the document discusses the importance of data management and storage. It emphasizes the need to ensure that data is securely stored and backed up, and that it is accessible to those who need it for analysis and reporting.

5. The fifth part of the document discusses the importance of data analysis and interpretation. It emphasizes the need to use appropriate statistical methods to analyze the data and to interpret the results in the context of the research objectives and the existing literature.

6. The sixth part of the document discusses the importance of data reporting and communication. It emphasizes the need to present the results of the research in a clear and concise manner, using appropriate visual aids to enhance the presentation of the data.

7. The seventh part of the document discusses the importance of data archiving and preservation. It emphasizes the need to ensure that the data is preserved for future use and that it is accessible to those who need it for research and reporting.

Fuel Recommendations / Specifications

Warning: Do not mix gasoline or alcohol with diesel fuel. This mixture can cause an explosion.



Caution: Due to the precise tolerances of diesel injection systems, it is extremely important that the fuel be kept clean and free of dirt or water. Dirt or water in the system can cause severe damage to both the injection pump and the injection nozzles.



Caution: Do NOT use diesel fuel blended with lube oil in engines equipped with a catalytic convertor (including all model year 1994 and beyond). Damage to legally required emission control may result.

Use ASTM No. 2 D fuel with a minimum Cetane number of 40. No. 2 diesel fuel gives the best economy and performance under most operating conditions. Fuels with Cetane numbers higher than 40 may be needed in high altitudes or extremely low ambient temperatures to prevent misfires and excessive Smoke.

At operating temperatures below 0 °C [32 °F], use a blend Of No. 1 D and No. 2 D fuels, also known as “winterized”

No. 2 D.

NOTE: No. 1 D fuel can be used, however, fuel economy will suffer.

Use low sulfur content fuel having a cloud point that is at least 10 degrees below the lowest expected fuel temperature. Cloud point is the temperature at which crystals begin to form in diesel fuel.

The viscosity of the fuel must be kept above 1.3 centistokes to provide adequate fuel system lubrication at 40 °C [104 °F].

For a more detailed description of fuel properties, refer to Fuel For Cummins Engines. Bulletin NO. 3379001.

The following chart lists acceptable alternate fuels for MidRange engines.

Acceptable Alternate Fuels-Component Wear/Durability							
Fuel Type	Bosch			Nippondenso	Stanadyne	Lucas CAV	
	A	P7100	VE	Ep-9	DB-4	DPA	DPS
NO. 1-D Diesel	OK	OK	OK	OK	OK	OK	OK
NO. 2 Fuel Oil	OK	OK	OK	OK	OK	OK	OK
NO. 1-K Kerosene	OK	OK		OK	*	*	*
NO. 2-K Kerosene	OK	OK		OK	*	*	*
Jet-A	OK	OK		OK	*	*	*
Jet A-1	OK	OK		OK	*	*	*
JP-5	OK	OK		OK	*	*	*
JP-8	OK	OK		OK	*	*	*
Jet-B	Not ok	Not ok	Not ok	Not ok	Not ok	Not ok	Not ok
JP-4	Not ok	Not ok	Not ok	Not ok	Not ok	Not ok	Not ok
Cite	Not ok	Not ok	Not ok	Not ok	Not ok	Not ok	Not ok

*OK ONLY if 5% new lube oil is blended with these fuels to increase the lubricity to acceptable level.

Caution: Do NOT use diesel fuel blended with lube oil in engines equipped with a catalytic convertor (including all model year 1994 and beyond). Damage to legally required emission control may result.

NOTE: Any adjustment to compensate for reduced performance with a fuel system using alternate fuel is not warrantable.

NOTE: Wear on any mid-ranged fuel pump component attributed to the lack of lubrication in the fuel is not a warrantable repair.

Lubricating Oil Recommendations / Specifications

Oil Performance Recommendations

The use of quality engine lubricating oils combined with appropriate oil drain and filter change intervals are critical factors in maintaining engine performance and durability.

Cummins Engine Company, Inc. recommends the use of a high quality SAE 15W-40 heavy duty engine oil (such as Cummins Premium Blue) which meets the American Petroleum Institute (API) performance classification CE/SG.

NOTE: CC / CD or CD / SF engine oils can be used in areas where CE oil is not yet available, but the oil change interval must be reduced to one half the interval given in the maintenance schedule.

A sulfated ash limit of 1.0 mass percent is suggested for optimum valve and piston deposit and oil consumption control. The sulfated ash must not exceed 1.85 mass percent.

oil Viscosity Recommendations

The use of multi-viscosity lubricating oil has been found to improve oil consumption control and improve engine cranking in cold temperatures while maintaining lubrication at high operating temperatures.

While 15W-40 oil is recommended for most climates, refer to the accompanying table for oil viscosity recommendations for extreme climates.

Section V-Specifications and Torque Values

B Series

NOTE: Limited use of low viscosity oils, such as 10W-30 may be used for easier starting and providing sufficient oil flow at ambient temperatures below -5°C [23°F]. However, continuous use of low viscosity oils can decrease engine life due to wear. Refer to the accompanying chart.

Lubricating Oil Recommendations / Specifications

Page V-13

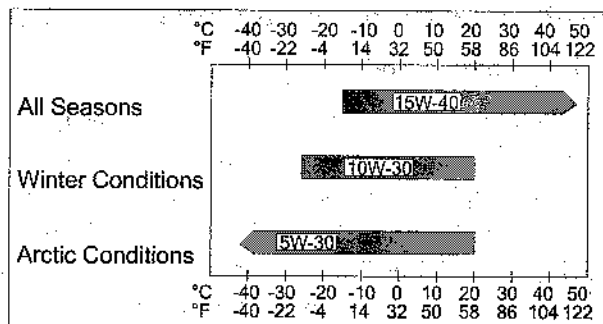

New Engine Break-In Oils

Do not use special "break-in" lubricating oils for new or rebuilt Cummins engines. Use the same type of oil during the "break-in" as that which is used in normal operation.

Recommended Oil Change Intervals

Refer to the following flowchart for the recommended oil change interval based on engine application.

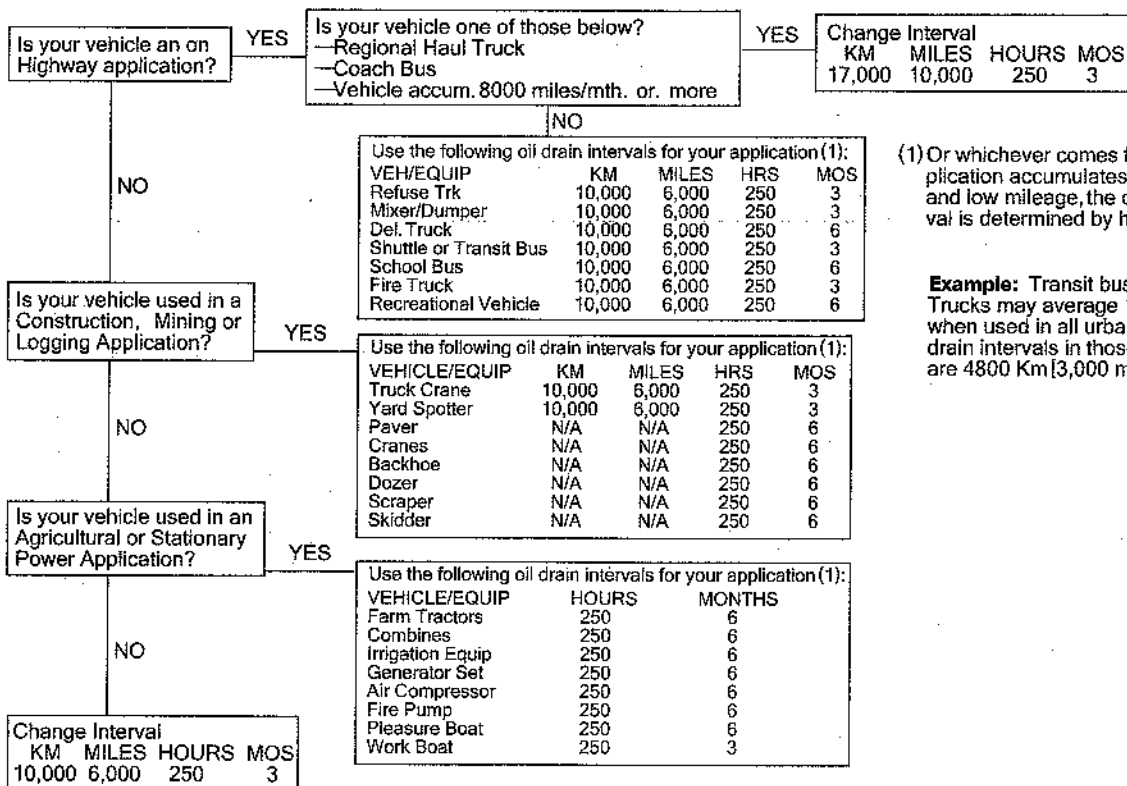

(1) Or whichever comes first. If your application accumulates high hours and low mileage, the change interval is determined by hours.

Example: Transit buses and refuse Trucks may average 16 Km [10 MPH] when used in all urban routes. Oil drain intervals in those applications are 4800 Km [3,000 mi], or less.

Oil Consumption

In addition to the information that follows, a service publication entitled Technical Overview of Oil Consumption is available, Bulletin 3379214-00.

Cummins defines "Acceptable Oil Usage" as outlined in the following table:

ACCEPTABLE OIL USAGE									
ANY TIME DURING COVERAGE PERIOD									
ENGINE FAMILY	HRS PER QT	HRS PER LITER	HOURS PER IMPERIAL QUART	MILES PER QUART	MILES PER LITER	MILES PER IMPERIAL QUART	KILOM PER QUART	KILOM PER LITER	KILOM PER IMPERIAL QUART
4B	10.0	10.6	12.0	400	425	475	650	675	775
6B	10.0	10.6	12.0	400	425	475	650	675	775
6C	10.0	10.6	12.0	400	425	475	650	675	775

Arctic Operation

If an engine is operated in ambient temperatures consistently below -23°C [-10°F] and there are no provisions to keep the engine warm when it is **not** in operation, use a synthetic CE/SG engine oil with adequate low temperature properties such as; 5W-30.

The oil supplier **must** be responsible for meeting the performance service specifications.



Caution: The use of a synthetic base oil does not justify extended oil change intervals. Extended oil change intervals can decrease engine life due to factors such as; corrosion, deposits and wear.

Additional information regarding lubricating oil availability throughout the world is available in the "E. M. A. Lubricating oils Data Book for Heavy Duty Automotive and Industrial Engines." The data book may be ordered from the engine Manufacturers Association, One Illinois Center, 111 East Wacker Drive, Chicago, IL U. S. A. 60601. The telephone number is: (312) 644-6610.

Coolant Recommendations / Specifications

Heavy duty diesel engines require a balanced coolant mixture of water and antifreeze. Drain and replace the mixture every 2 years, 320,000 KM [200,000 miles] or 6,000 hours of operation (whichever occurs first) to eliminate build up of harmful chemicals.

- **Antifreeze is essential in any climate.** It broadens the operating temperature range by lowering the coolant freezing point and by raising its boiling point. Do **not** use more than 50 percent antifreeze in the mixture unless additional freeze protection is required. **Never** use more than 68 percent antifreeze under any condition.
- Use soft water in the coolant mixture. Contaminants in hard water neutralize the corrosion inhibitor components. Water must not exceed 300 ppm hardness, or contain more than 100 ppm of either chloride or sulfate.
- **Specifications-Use low silicate antifreeze which meets ASTM4985 test(GM6038M spec.)criteria.**

Concentration-Antifreeze must be used in any climate for both freeze and boiling point protection.

Cummins recommends a 50 percent concentration level(40 percent to 60 percent range)of ethylene glycol or propylene glycol in most climates. Antifreeze at 68 percent concentration provides the maximum freeze Protection and **must** never be exceeded under any Condition. Antifreeze Protection decreases above 68 percent.

Ethylene Glycol	Propylene Glycol
40% = -23°C [-10°F]	40% = -21°C [-6°F]
50% = -37°C [-34°F]	50% = -33°C [-27°F]
60% = -54°C [-65°F]	60% = -49°C [-56°F]
68% = -71°C [-90°F]	68% = -63°C [-82°F]

Concentration Testing-Antifreeze concentration must be checked using a refractometer(such as Fleet-guard Part No.Cc2800).“Floating ball”type density testers or hydrometers are not accurate enough for use with heavy duty diesel cooling systems.

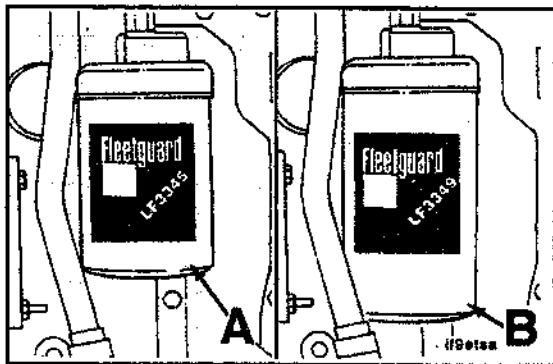

Filter Selection

Oil Filters

A = LF 3345 Standard Four Cylinder Applications

B = LF 3349 Standard Six Cylinder Applications

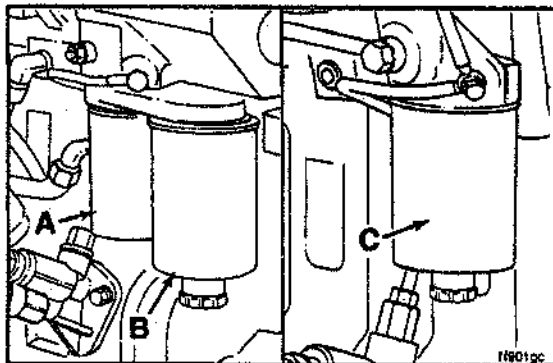

Fuel Filters

A = Standard Filter used as secondary filter in fuel filter applications.

B = Fuel Water Separator Primary filter for fuel filter applications.

C = Fuel Water Separator used in single filter applications.

Engine Component Torque Value

Socket or Wrench Size MM(Inch)		Torque N · m	(Ft-lb)
10	Aftercooler Mounting.....	24	[18]
8	Aftercooler Water Hose Clamp.....	5	[4]
13	Alternator Link (Delco 10-15 SI).....	24	[18]
[3/4]	Alternator Link (Delco 20-27 SI).....	43	[32]
15	Alternator Mtg. Bolt 10-15 SI.....	43	[32]
18	Alternator Mtg. Bolt 27 SI.....	77	[57]
10	Alternator Support (Upper).....	24	[18]
Allen 5 mm	Belt Tensioner Flat Bracket.....	24	[18]
15	Belt Tensioner Mounting.....	43	[32]
15	Crankshaft Damper & Pulley.....	137	[101]
[5/16]	Crossover Clamp.....	5	[4]
11	Tee Bolt Type Clamp.....	8	[6]
15	Exhaust Manifold.....	43	[32]
15	Exhaust Outlet Pipe Mtg Bracket.....	43	[32]
(7/16)	Exhaust Outlet Pipe, V Band Clamp.....	8	[6]
10	Fan Bracket Mounting.....	24	[18]
10	Fan Pulley.....	24	[18]
13	Fan Pulley.....	43	[32]
19	Flywheel.....	137	[101]
--	Front Cover Clamp Access Cap.....	-----Hand Tighten-----	
17	Fuel Drain Line Banjo Screw (Rotary Pump).....	15	[11]

Engine Component Torque Value (Continued)

Socket or Wrench Size MM(Inch)		Torque N · m	(Ft-lb)
17	Fuel Banjo Screw (in Filter Head).....	24	[18]
10	Fuel Vent Screw (in Banjo).....	9	[7]
10	Fuel Banjo Screw (Injector).....	9	[7]
75-85	Fuel Filter.....	3/4 Turn After Contact	
24	Fuel Filter Adapter Nut.....	32	[24]
17 or 19	Fuel Line Fitting (High Pressure).....	30	[22]
22	Fuel Pump Drive Gear (with Pump Unlocked) Rotary.....	65	[48]
22	Fuel Pump Drive Gear (Pump Unlocked) Nippondenso.....	123	[92]
30	Fuel Pump Drive Gear (Pump Unlocked) Bosch In-line.....	165	[122]
10	Fuel Pump Lock (Bosch) Rotary.....	30	[22]
	Fuel Pump Unlock (Bosch) Rotary.....	13	[10]
14	Fuel Pump Lock (CAV).....	7	[5]
	Fuel Pump Unlock (CAV).....	20	[15]
13	Fuel Pump Mounting Nuts (Bosch Rotary).....	24	[18]
15	Fuel Pump Mounting Nuts (Bosch In-Line, Nippondenso).....	43	[32]
13	Fuel Pump Mounting Nuts (CAV).....	30	[22]
13	Fuel Pump Support Bracket.....	24	[18]
24	Injector Retaining Nut.....	60	[44]
13	Intake Manifold Cover.....	24	[18]
10	Lift Pump/Cover Plate.....	24	[18]
18	Lifting Bracket (Rear).....	77	[57]

Section V-Specificatons and Torque Values

Engine Component Torque Value

B series

Page V-21

Socket or Wrench Size MM(Inch)		Torque N · m	(Ft-lb)
75-85	Oil Filter.....	3/4 Turn After Contact	
10	Oil Cooler Assembly.....	24	[18]
17	Oil Pan Drain Plug.....	80	[60]
27	Oil Pan Heater Plug.....	80	[60]
19	Oil Pressure Regulator Plug.....	80	[60]
10	Rear Seal Housing.....	9	[7]
14	Rocker Lever Nut.....	24	[18]
10	Starter Mounting.....	43	[32]
10	Tappet Cover/Fuel Drain Line Supports.....	24	[18]
10	Thermostat Housing.....	24	[18]
13	Turbine Housing.....	11	[8]
10	Turbo Compressor Housing Clamp.....	6	[5]
15	Turbo Mounting Nuts.....	32	[24]
13	Turbo Drain Tube.....	24	[18]
16	Turbo Oil Supply (Both Ends).....	24	[18]
15	Water Inlet Connection.....	43	[32]
13	Water Pump Mounting.....	24	[18]
15	Valve Cover.....	24	[18]
--	Valve Cover Oil Fill.....	Hand Tighten	

Sealants

Use the sealants listed below or sealants containing equivalent properties.

Description	Sealing Method
1. Pipe Plugs	Precoated teflon or pipe sealer.
2. Cup Plugs	Loctite 277 or 11,264
3. O-Rings	No sealant required.
4. Rear Camshaft Expansion Plug	Precoated or Loctite 59,241 liquid teflon.
5. Fuel Pump Studs	Loctite 609.
6. Turbo Drain in Block	Loctite 277 or 11,264
7. Front Seal in Gear Cover	Loctite 277 or 11,264
8. Rear Seal in Rear Cover	No sealant.
9. Oil Pan at T-Joint	3-Bond 1207C (P/N 3823494)

Capscrew Markings and Torque Values

⚠ Caution: When replacing capscrews, always use a capscrew of the same measurement and strength as the capscrew being replaced. Using incorrect capscrews can result in engine damage.

Most of the capscrews used on the B Series engine are metric. Some components, such as the air compressor and fuel pump, are installed using U. S. Customary capscrews.

Metric capscrews and nuts are identified by the grade number stamped on the head of the capscrew, or on the surface of the nuts. U. S. Customary capscrews are identified by radial lines stamped on the head of the capscrew.

The following examples indicate how capscrews are identified:

Metric (M8-1.25×25)		
M8	1.25	25
Major Thread Diameter in	Distance Between Threads in	Length in Millimeters

U. S. Customary (5/16×8×1 1/2)		
5/16	8	1 1/2
Major Thread Diameter in Inches	Number of Threads per Inch	Length in Inches

Notes:

1. **Always** use the torque values listed in the following tables when specific torque values are **not** available.
2. Do **not** use the torque values in place of those specified in other sections of this manual.
3. The torque values in the table are based on the use of lubricated threads.

Capscrew Markings and Torque Values-Metric

Commercial Steel Class

8.8

10.9

12.9

Capscrew Head Markings

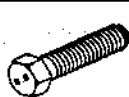

**Body
Size**

Torque

Torque

Torque

Diam.	Torque				Torque				Torque			
	Cast Iron		Aluminum		Cast Iron		Aluminum		Cast Iron		Aluminum	
mm	N · m	ft-lb	N · m	ft-lb	N · m	ft-lb	N · m	ft-lb	N · m	ft-lb	N · m	ft-lb
6	9	7	7	5	12	9	7	5	12	9	7	5
7	14	10	11	8	18	13	11	8	23	18	11	8
8	25	18	18	13	32	23	18	13	36	27	18	13
10	40	30	30	22	60	45	30	22	70	50	30	22
12	70	22	55	40	105	77	55	40	125	95	55	40
14	115	85	90	66	160	118	90	66	195	145	90	66
16	180	133	140	103	240	177	140	103	290	210	140	103
18	230	170	180	133	320	236	180	133	400	290	180	133

Section V - Specifications and Torque Values

Capscrew Markings and Torque Values - U.S. Customary

B series

Page V-25

Capscrew Markings and Torque Values - U.S. Customary

SAE Grade Number

5

8

These are all SAE Grade 5 (3) line
Capscrew Head Markings



Capscrew Torque-Grade 5 Capscrew

Capscrew Torque-Grade 8 Capscrew

Capscrew Body Size	Cast Iron		Aluminum		Cast Iron		Aluminum	
	N·m	ft-lb	N·m	ft-lb	N·m	ft-lb	N·m	ft-lb
1/4 - 20	9	7	8	6	15	11	12	9
- 28	12	9	9	7	18	13	14	10
5/16 - 18	20	15	16	12	30	22	24	18
- 24	23	17	19	14	33	24	25	19
3/8 - 16	40	30	25	20	55	40	40	30
- 24	40	30	35	25	60	45	45	35
7/16 - 14	60	45	45	35	90	65	65	50
- 20	65	50	55	40	95	70	75	55
1/2 - 13	95	70	75	55	130	95	100	75
- 20	100	75	80	60	150	110	120	90
9/16 - 12	135	100	110	80	190	140	150	110
- 18	150	110	115	85	210	155	170	125
5/8 - 11	180	135	150	110	255	190	205	150
- 18	210	155	160	120	290	215	230	170
3/4 - 10	325	240	255	190	460	340	365	270
- 16	365	270	285	210	515	380	410	300
7/8 - 9	490	360	380	280	745	550	600	440
- 14	530	390	420	310	825	610	660	490
1 - 8	720	530	570	420	1100	820	890	660
- 14	800	590	650	480	1200	890	960	710